

### POINT 512

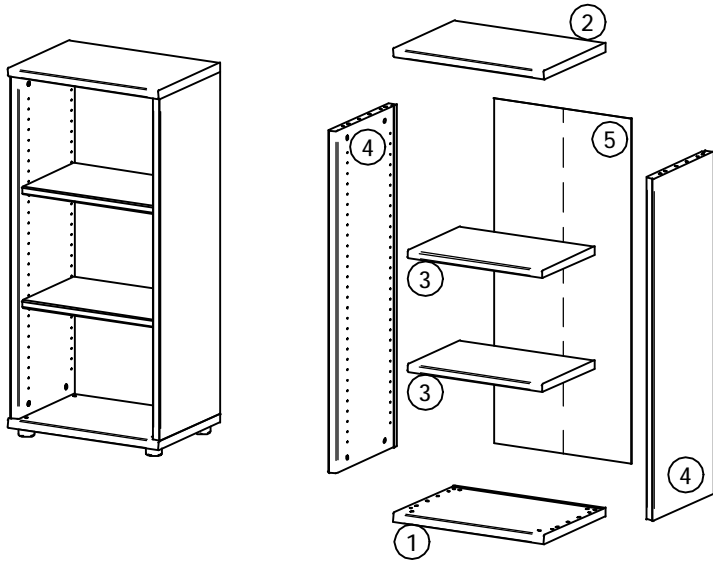

D	x8	EA	$\varnothing 10 \times 45$ x16	G	$\varnothing 5$ x8	I	x4
JD	$\varnothing 4 \times 25$ x8	L	$\varnothing 15$ x8	M	$\varnothing 8$ x8		
		KD	$\varnothing 15$ x8			Z	$\varnothing 5/2 \times 28$ x2

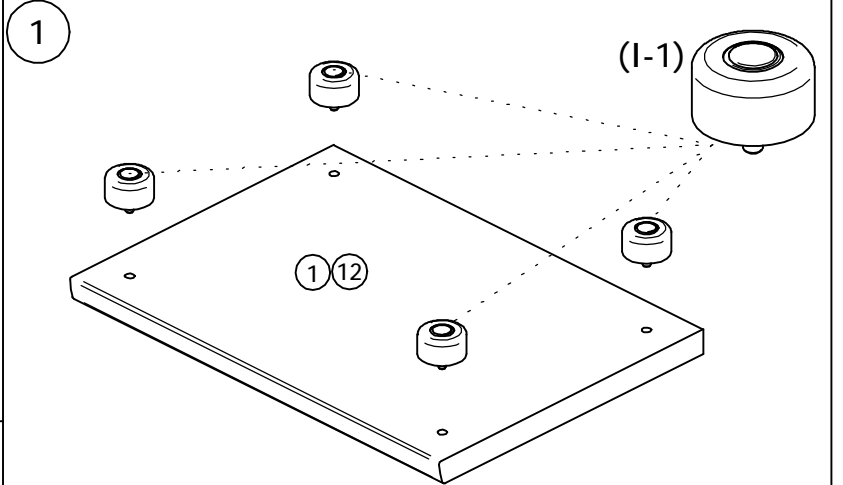

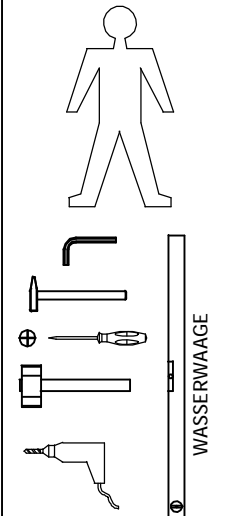

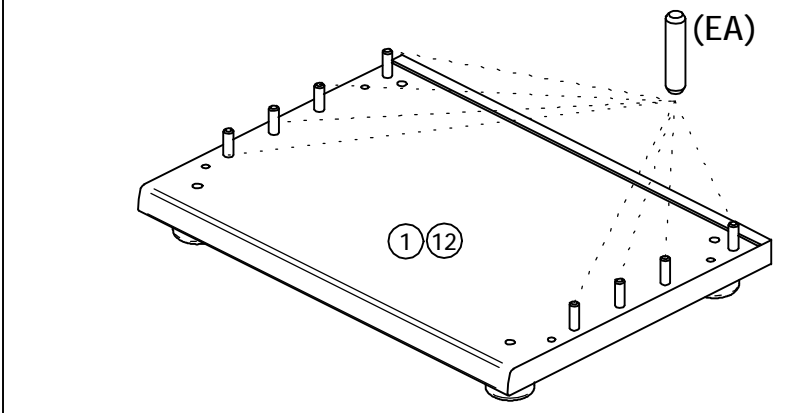
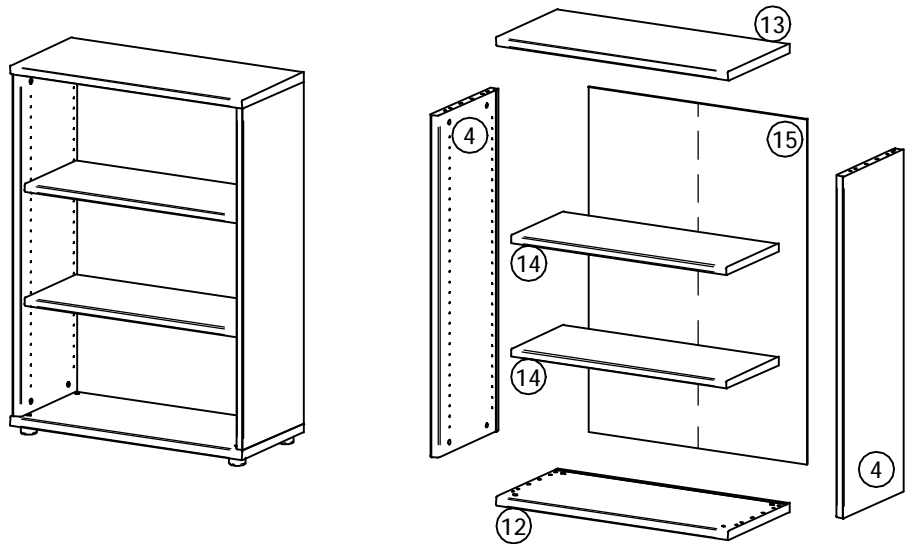

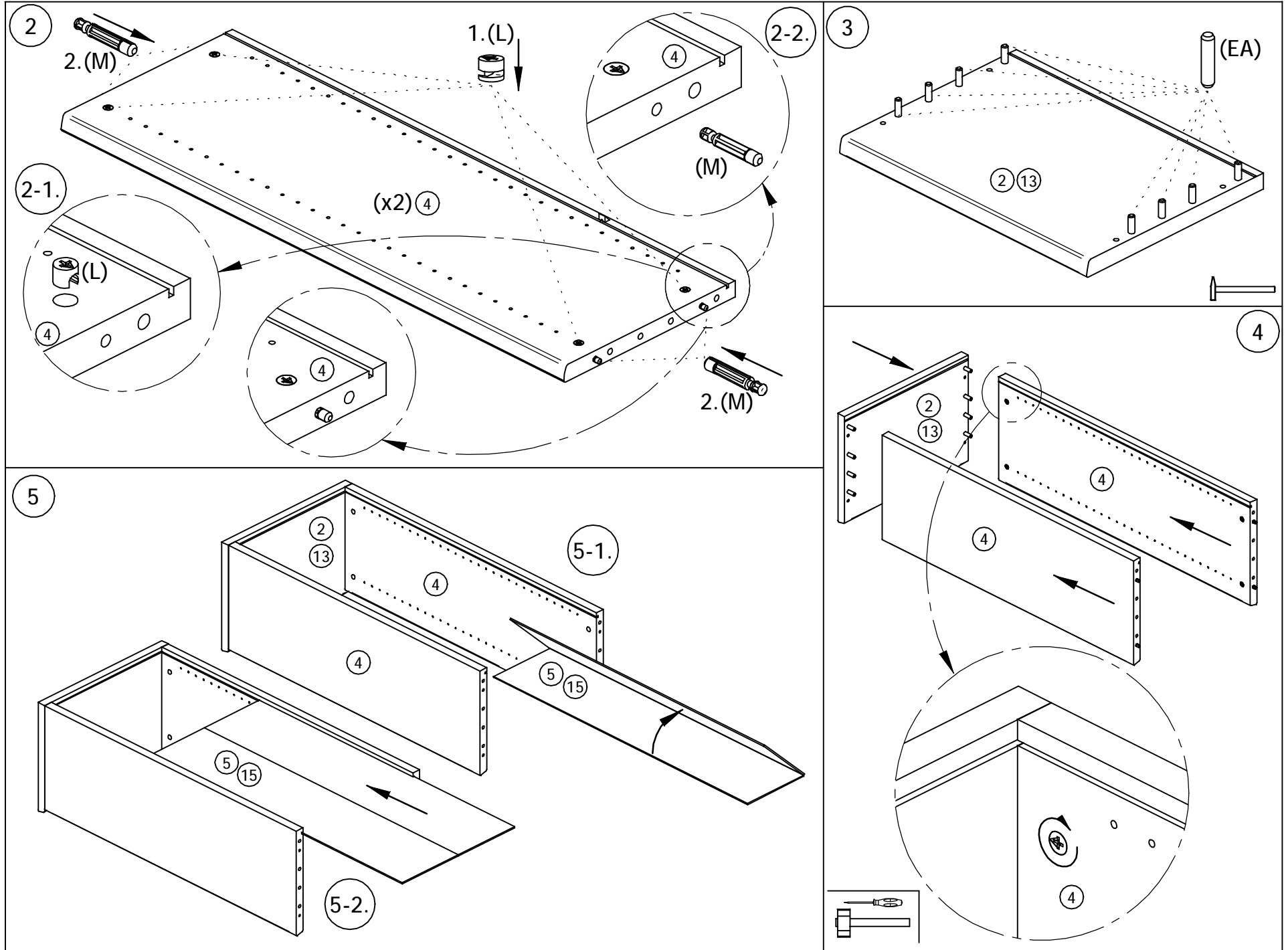

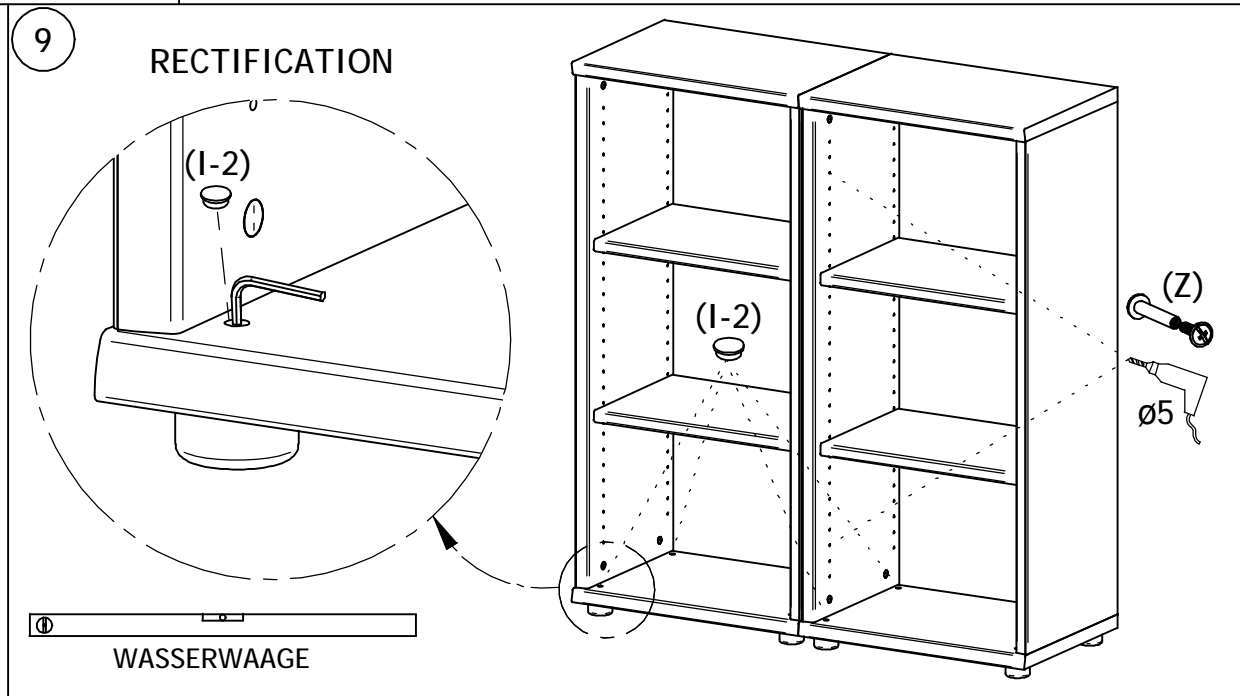
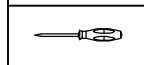
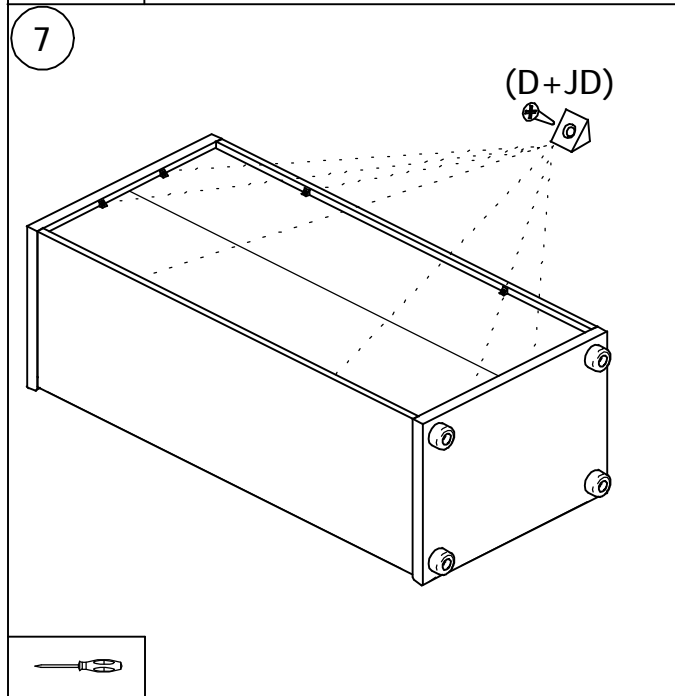
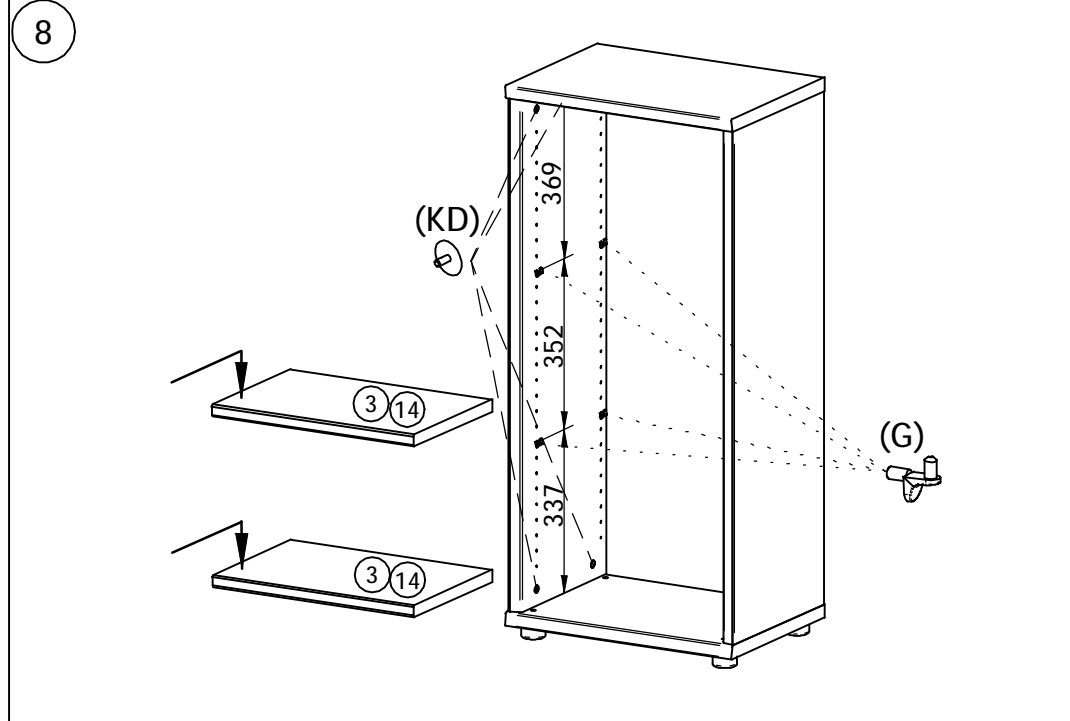
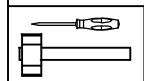
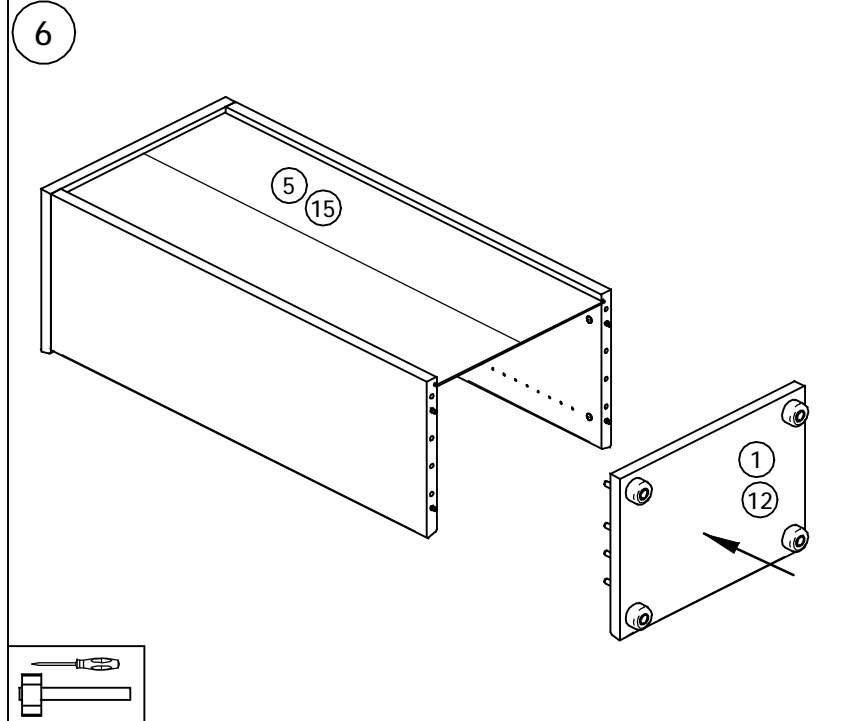

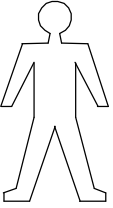
### POINT 812



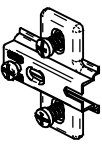
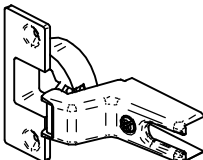



 	AA	 x2	AC	 M4x23 x4	B		POINT T 81 RG x4	C		POINT T 81 RG x4
			AD	 x4			POINT T 82 RG x8			POINT T 82 RG x8
				KE	 x4		JA	 Ø3.5x15	POINT T 83 RG x8, POINT T 82 RG x16	POINT T 83 RG x8
										POINT T 84 RG x8
										POINT T 84 RG x16

① POINT T 81 RG

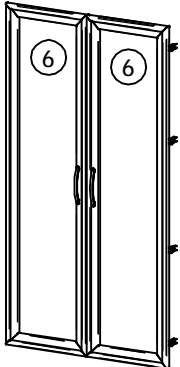
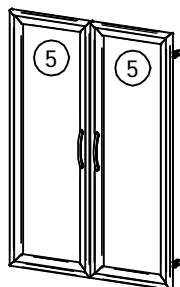

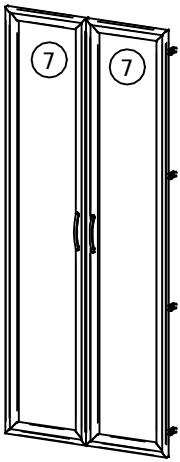
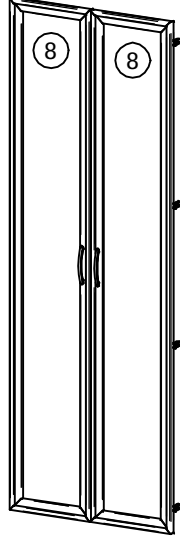

② POINT T 82 RG

④ POINT T 84 RG

③ POINT T 83 RG

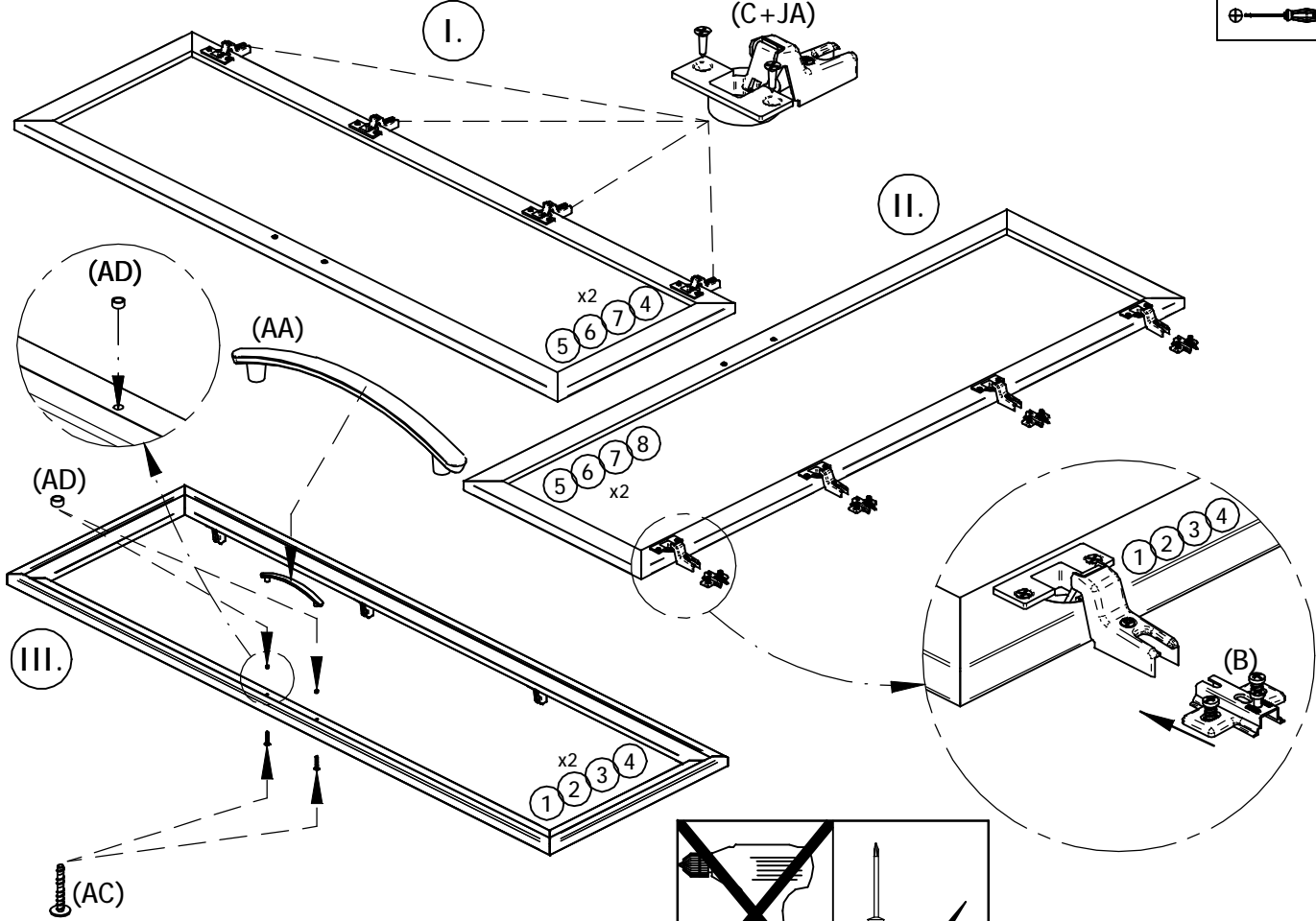

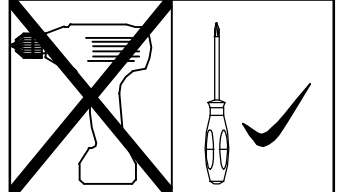

**ACHTUNG!!!**

BEI DER GRIFFMONTAGE AUSSCHIESSLICH DEN HANDSCHRAUBENZIEHER VERWENDEN.  
 PRI MONTÁŽI ÚCHYTKY POUŽÍVAJTE LEN RUČNÝ SKRUTKOVAČ.

2

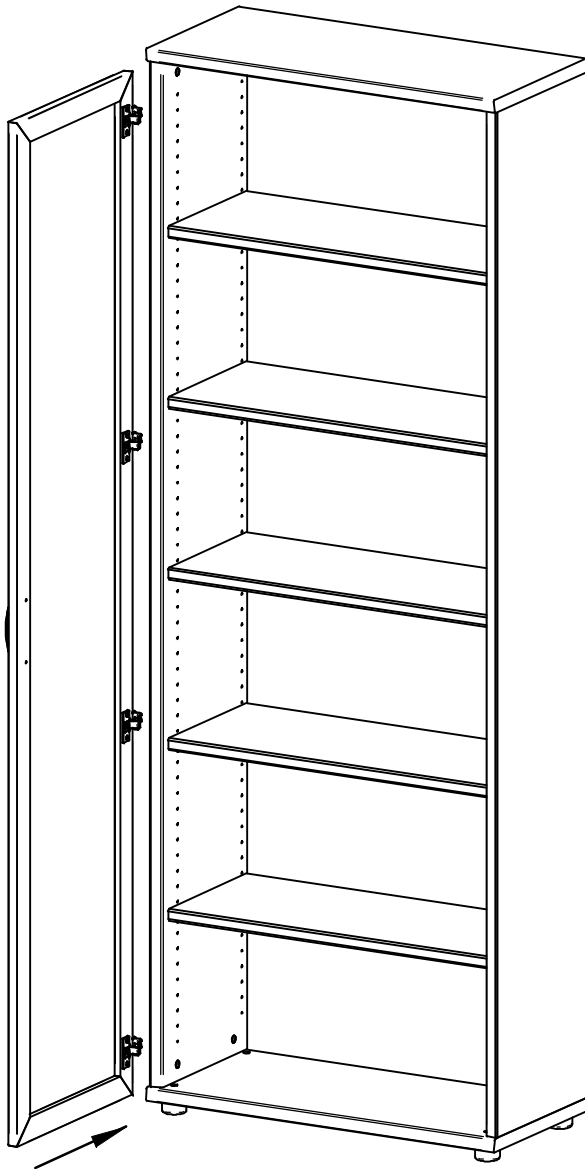

## NASTAVENIE DVERÍ / EINSTELLUNG VON TÜREN

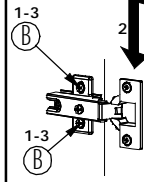

1. SKRUTKU B POVOLIŤ  
DIE SCHRAUBE B LÖSEN
2. DVERE VÝŠKOVO NASTAVIŤ  
TÜR IN DER HOHE EINSTELLEN
3. SKRUTKU B DOTIAHNŤ  
DIE SCHRAUBE B ZUZIEHEN

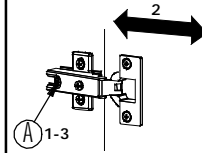

1. SKRUTKU A POVOLIŤ  
DIE SCHRAUBE A LÖSEN
2. DVERE HLĚKOVO NASTAVIŤ  
TÜR IN DER TIEFE EINSTELLEN
3. SKRUTKU A DOTIAHNŤ  
DIE SCHRAUBE A ZUZIEHEN

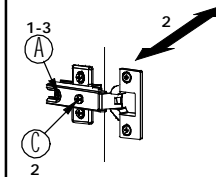

1. SKRUTKU A POVOLIŤ  
DIE SCHRAUBE A LÖSEN
2. DVERE STRANOVO SKRUTKOU C  
NASTAVIŤ  
TÜR SEITLIGS MIT SCHRAUBE C  
EINSTELLEN
3. SKRUTKU A DOTIAHNŤ  
SCHRAUBE A ZUZIEHEN

(KE)

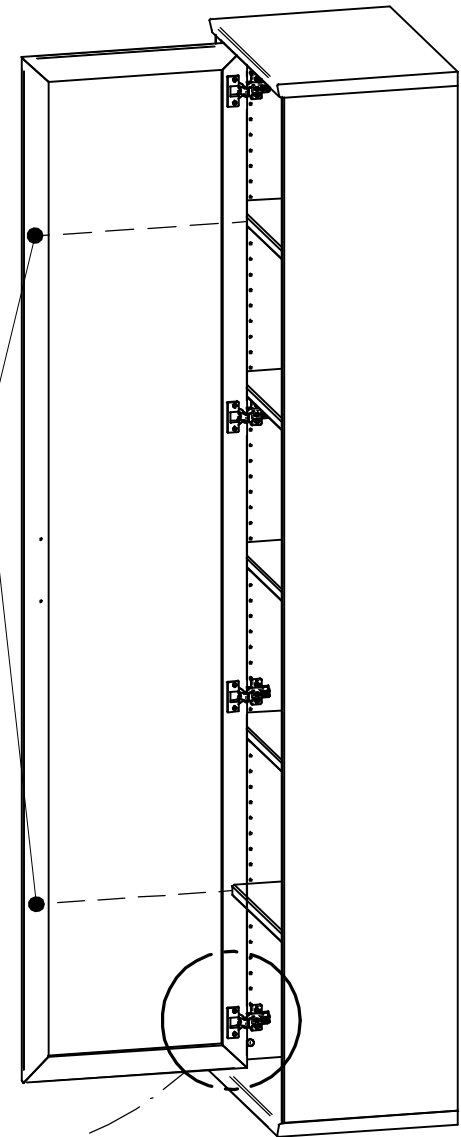
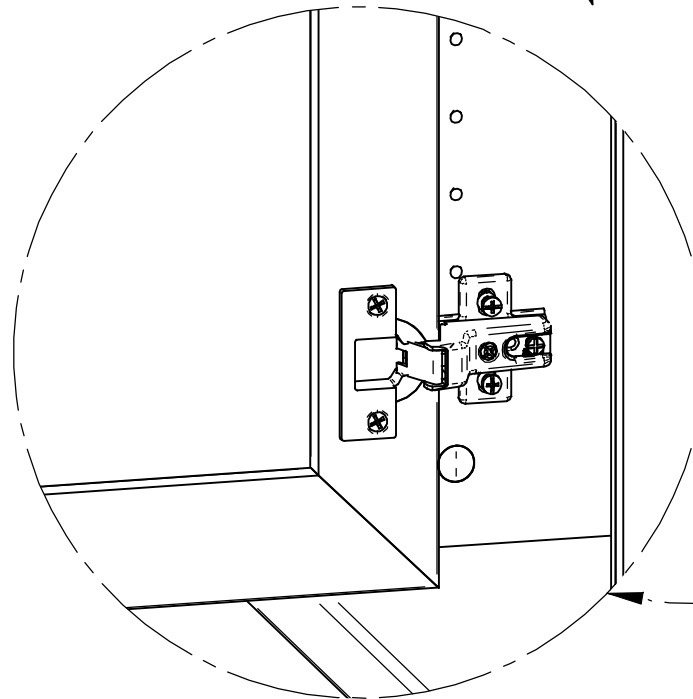

3

