

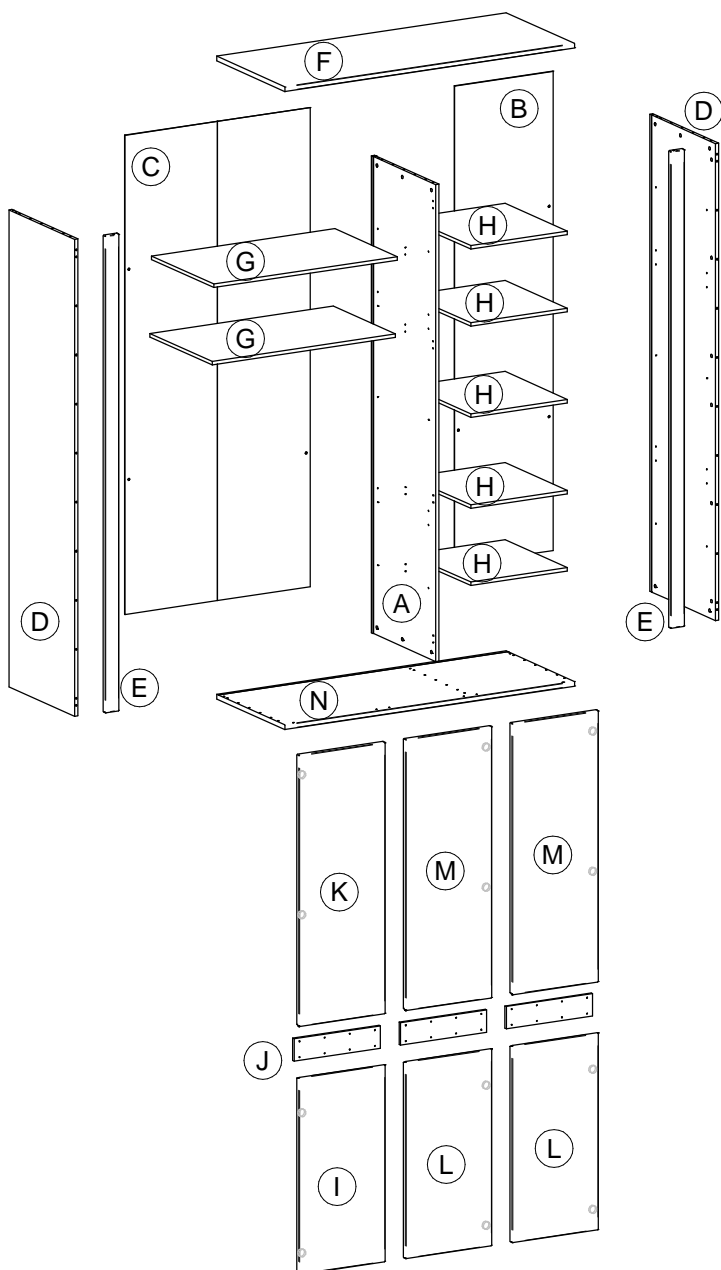

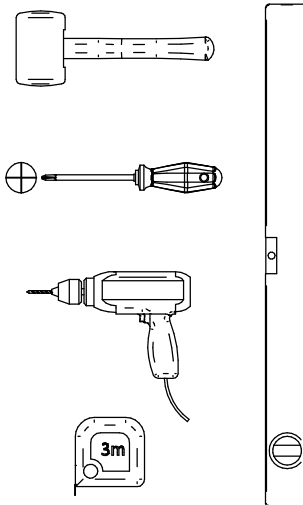

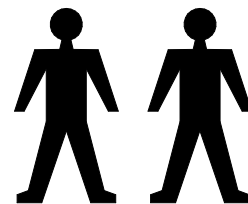

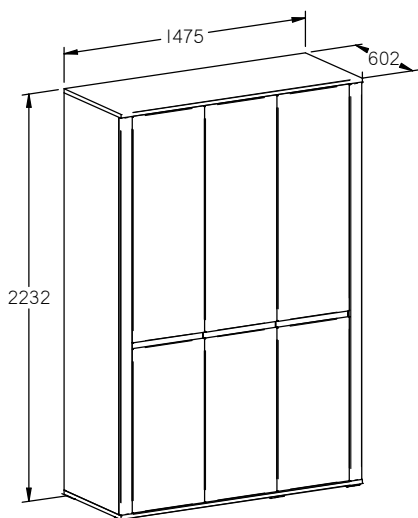

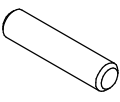
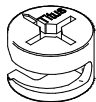
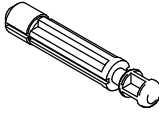

# MODESTO

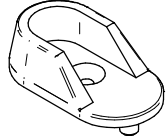
# 3DV

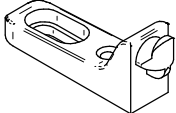
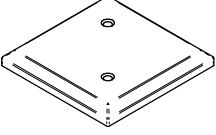

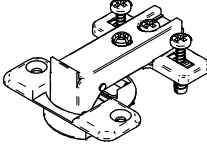
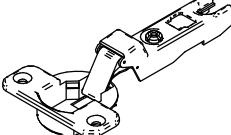
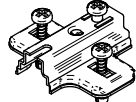
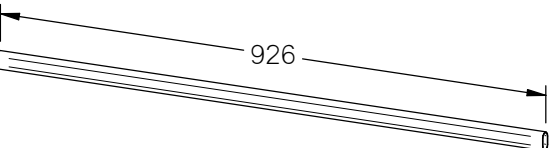
<b>1</b> ø8x35 x40 	<b>2</b> ø15 x30 	<b>3</b> ø8 x30 	<b>4</b> ø6,3x11 x8 	<b>5</b> ø4x25 x24 
<b>6</b> x28 	<b>7</b> x2 	<b>8</b> ø3,5x15 x36 	<b>9</b> ø4x20 x12 	<b>10</b> x8 
<b>11</b> x6 	<b>12</b> ø15 x12 	<b>13</b> x8 	<b>14</b> x4 	<b>15</b> x4 
<b>16</b> x2 926 	<b>17</b> ø5 x6 	<b>18</b> 		

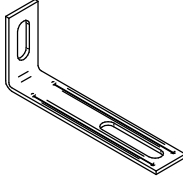
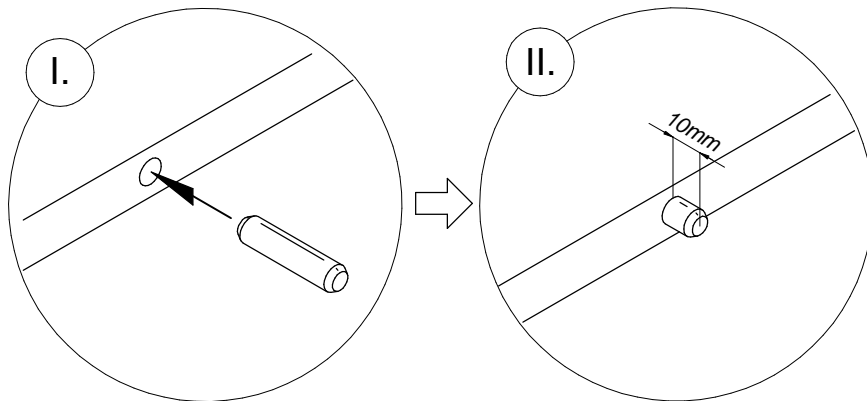
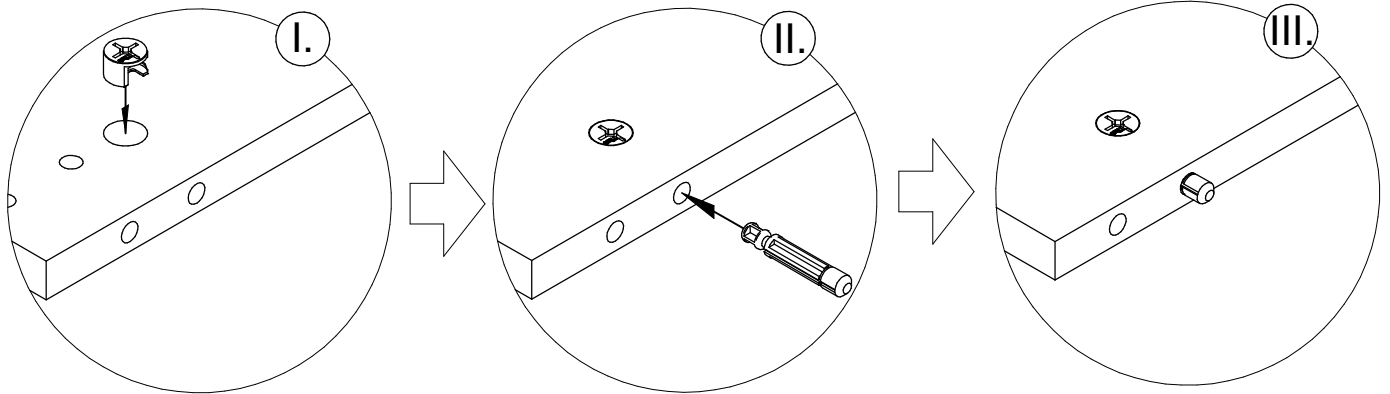

1

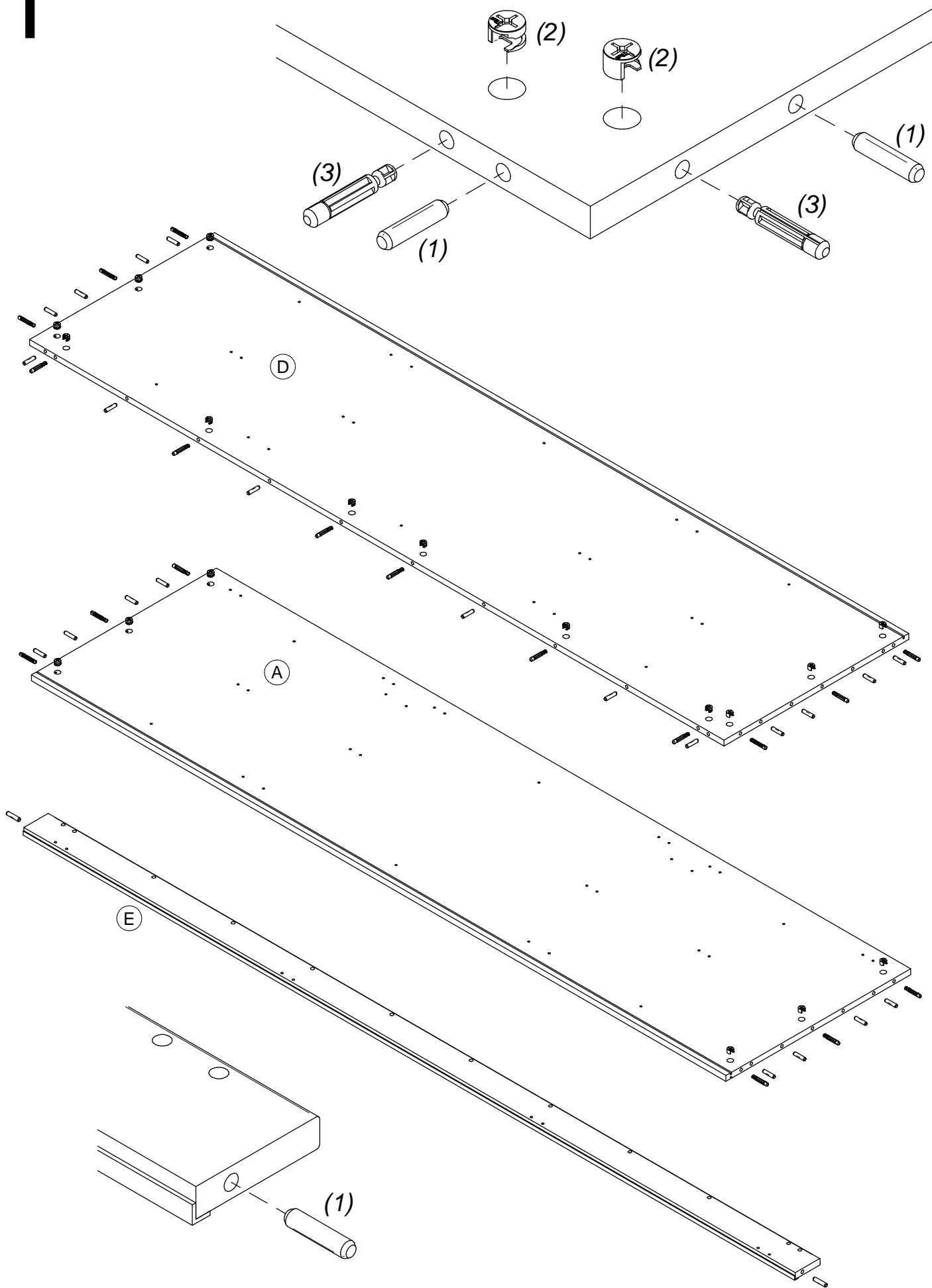

# 2

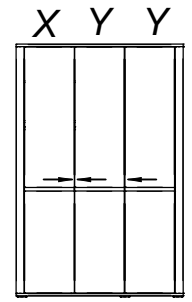

(X) 1x

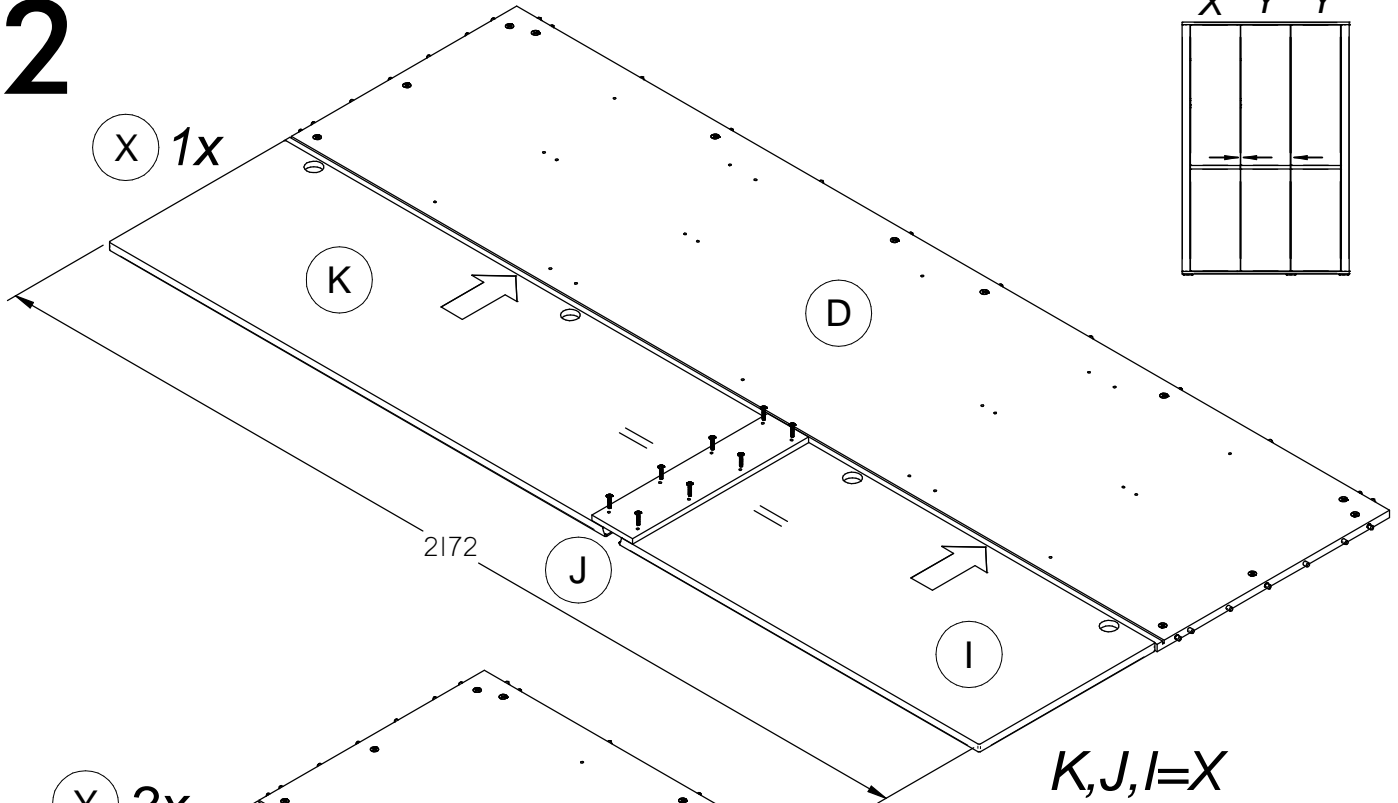

(Y) 2x

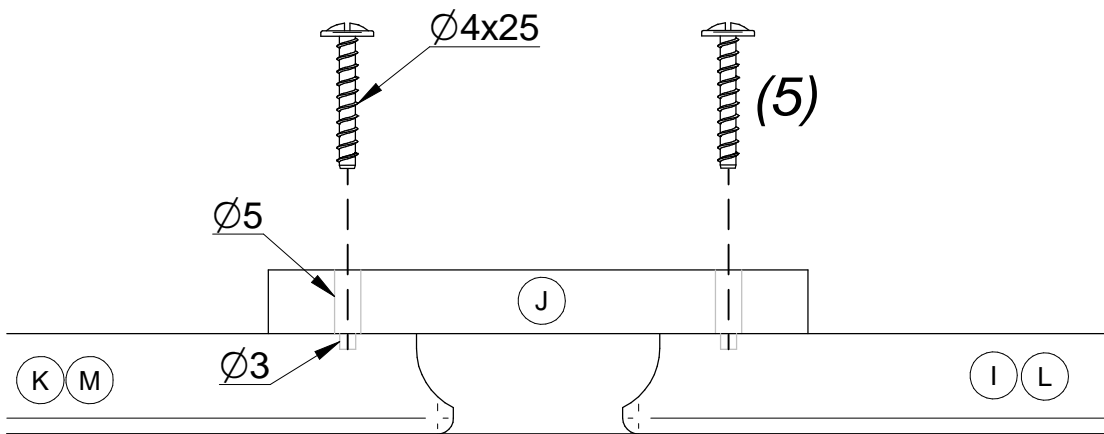
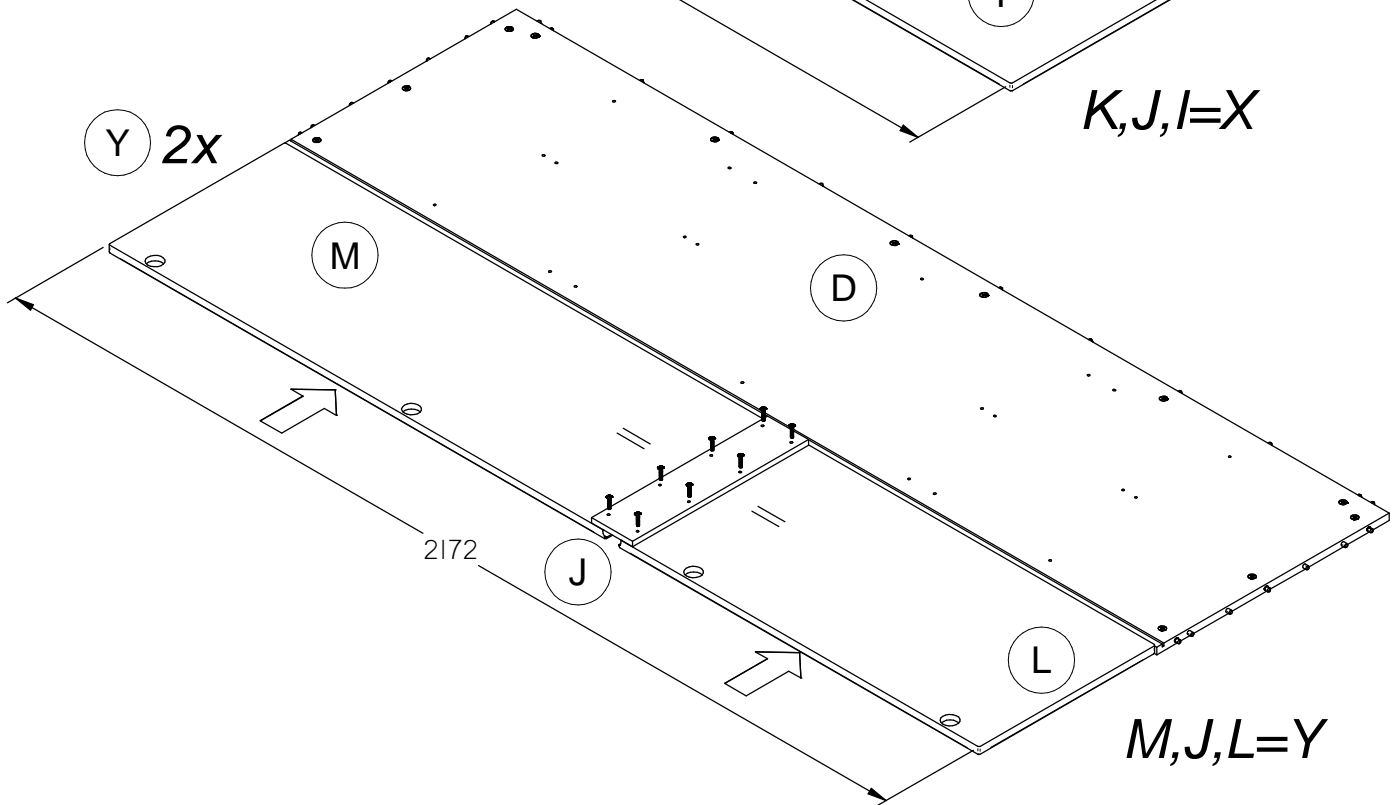

# 3

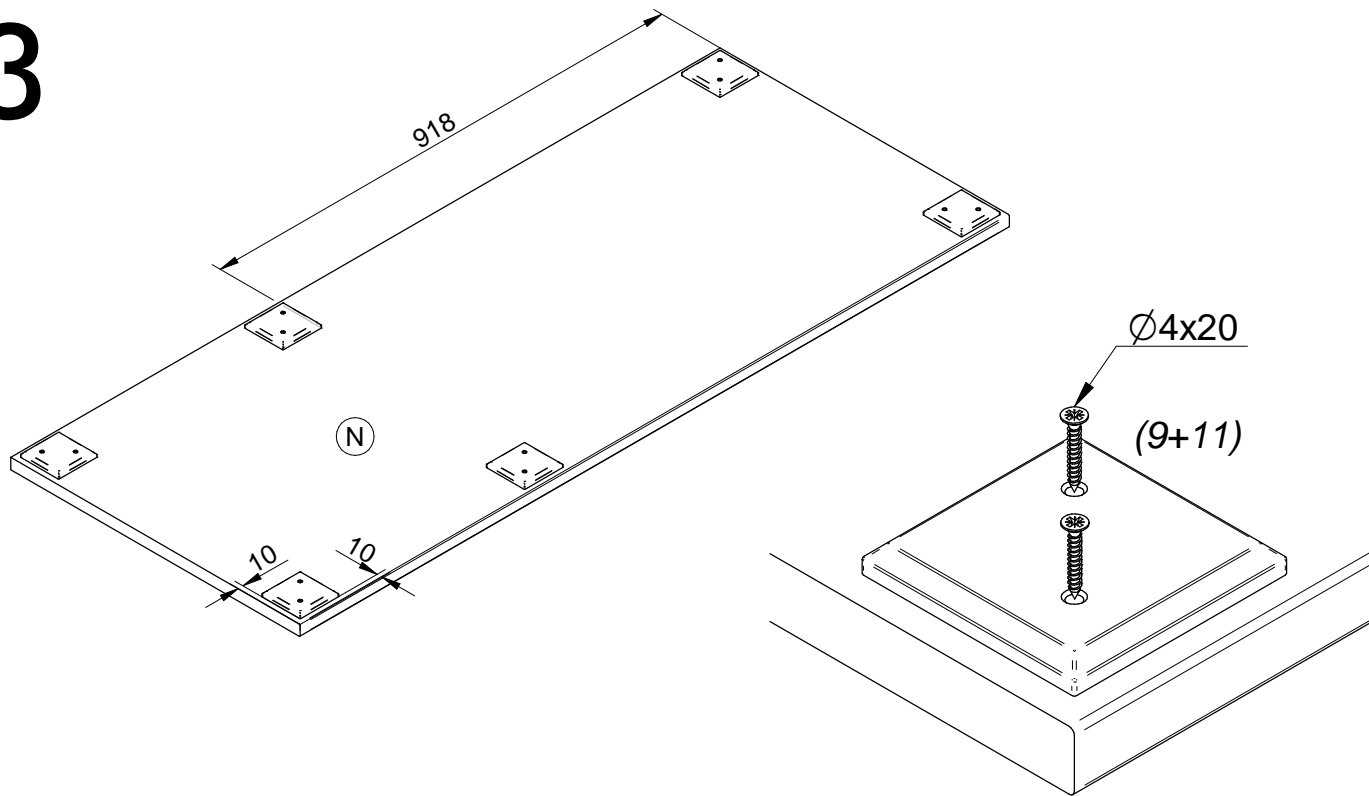

# 4

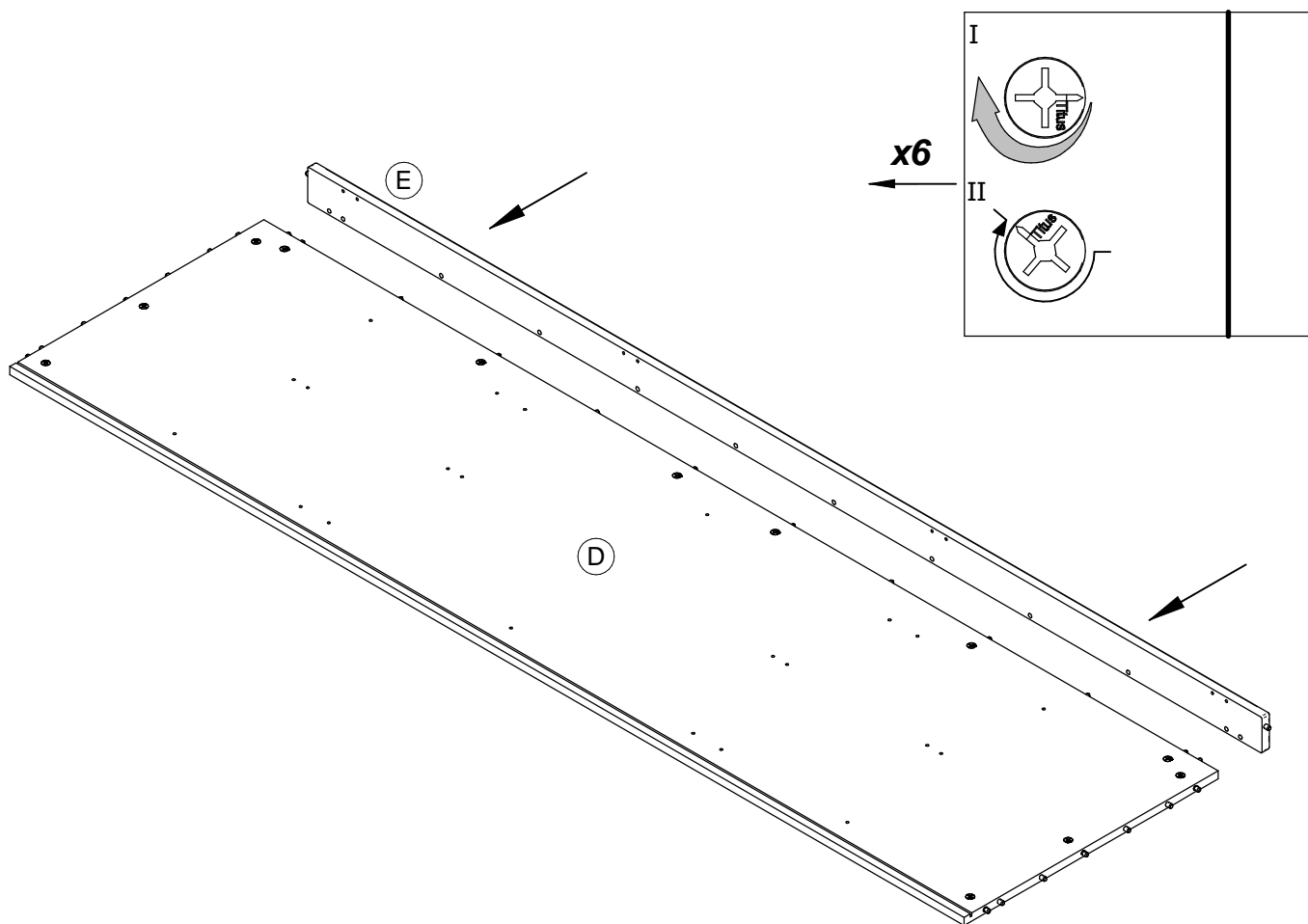

# 5

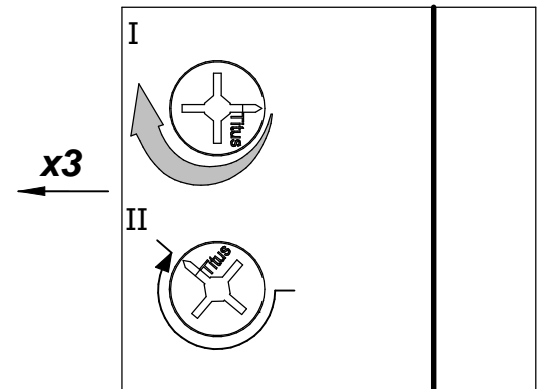
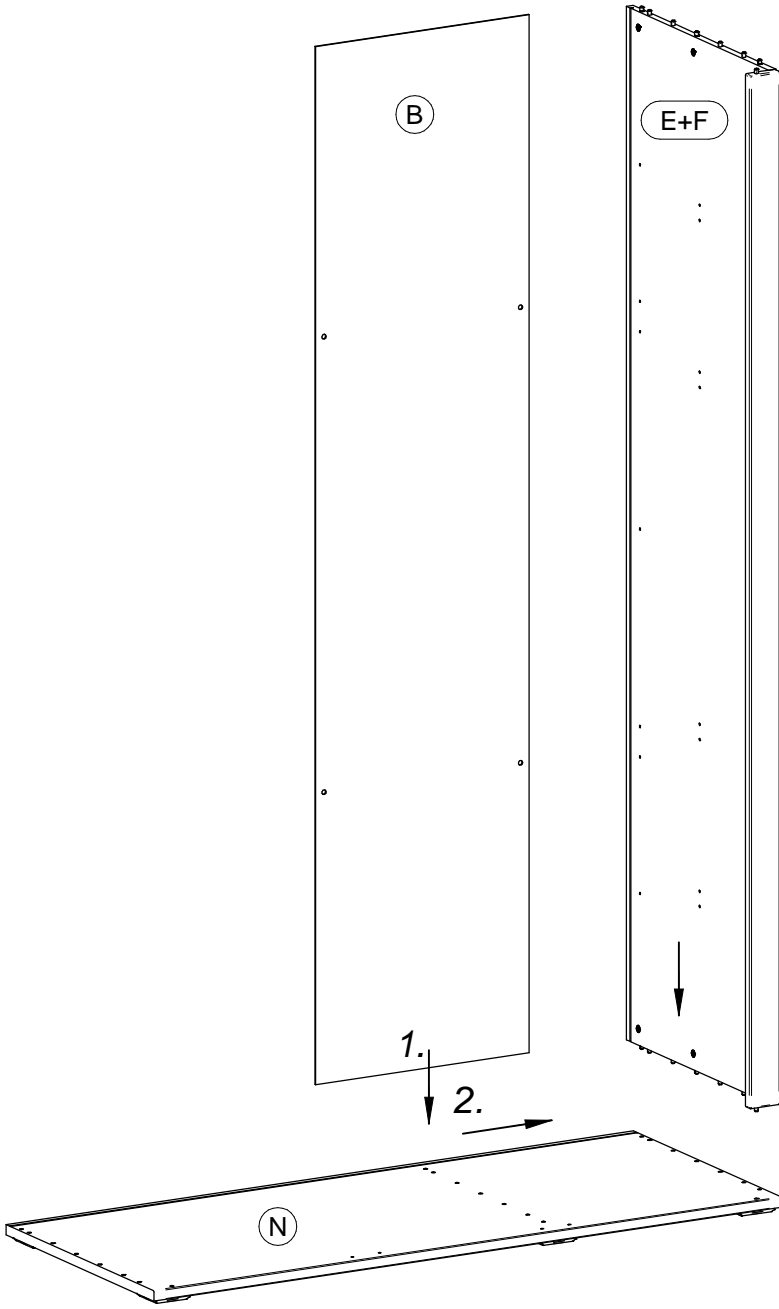

# 6

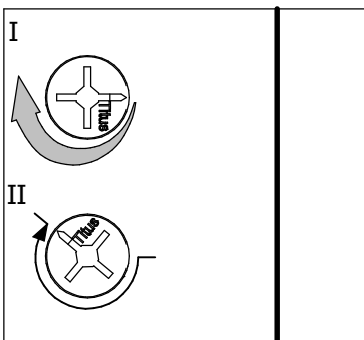
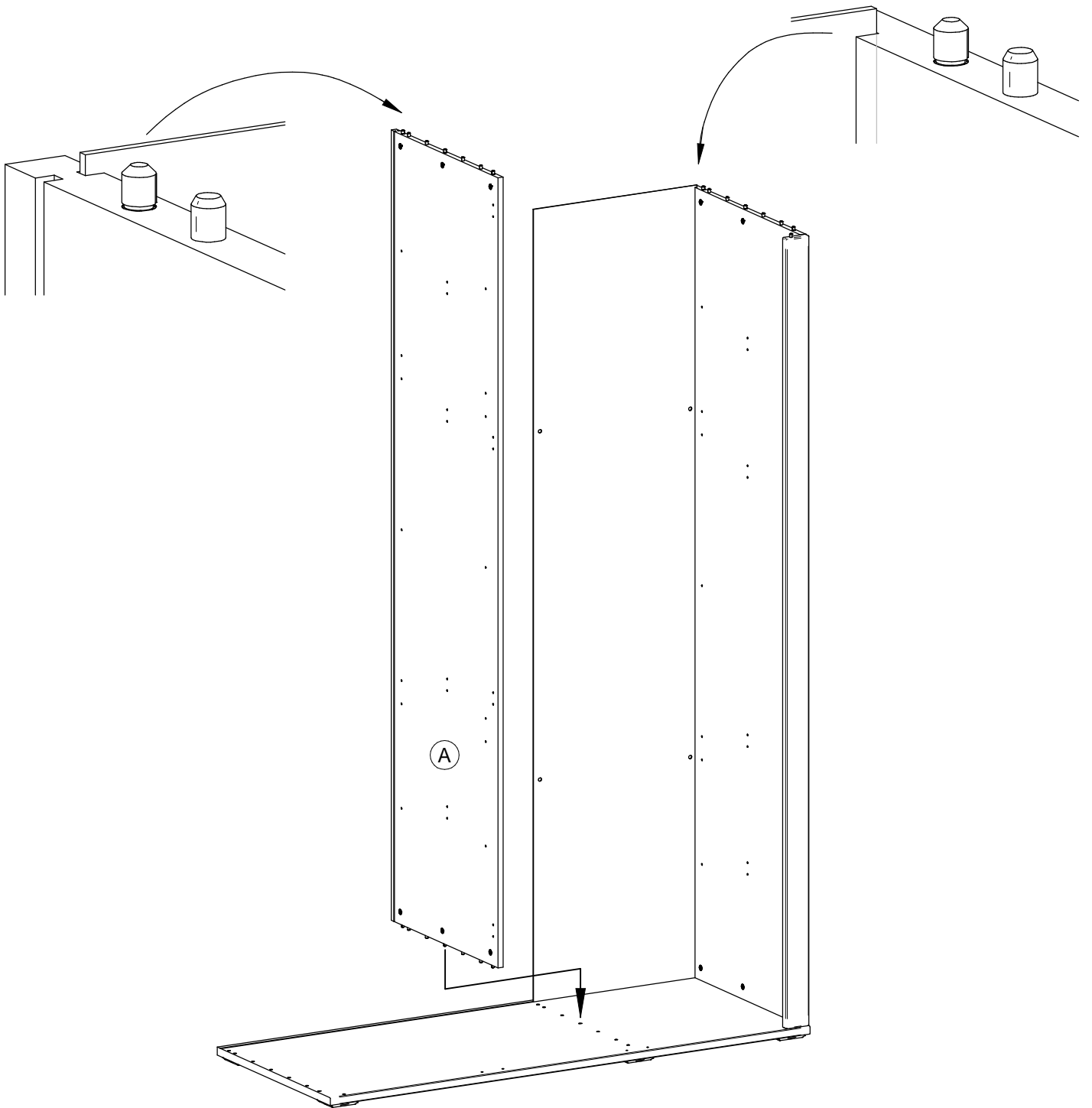

x3

# 7

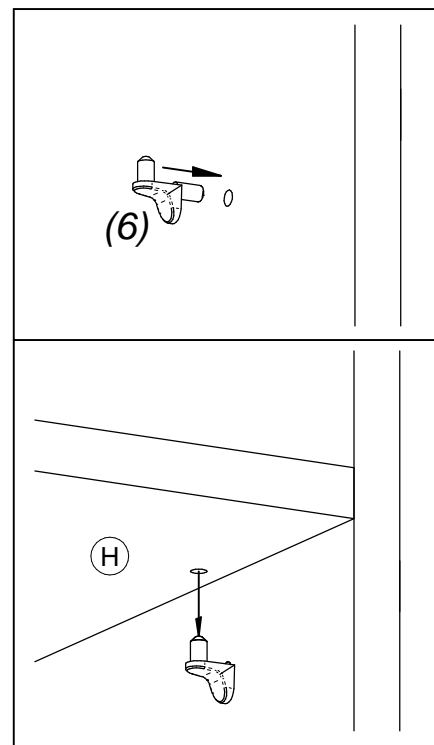
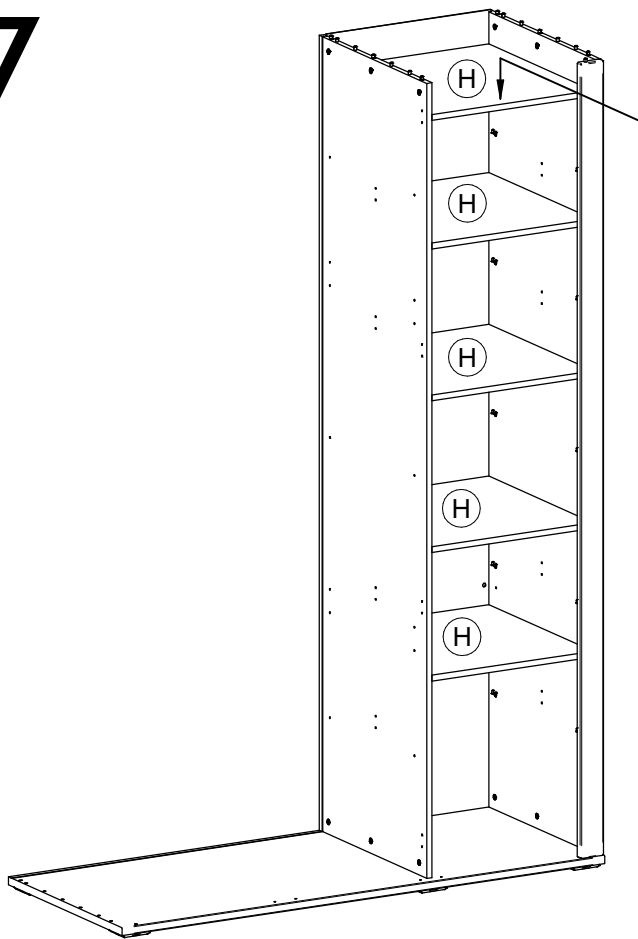

# 8

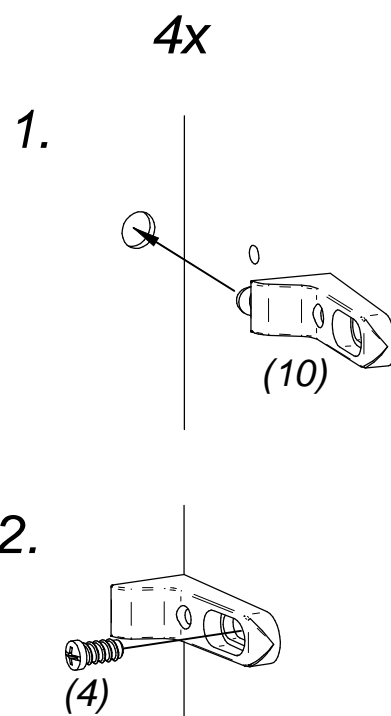
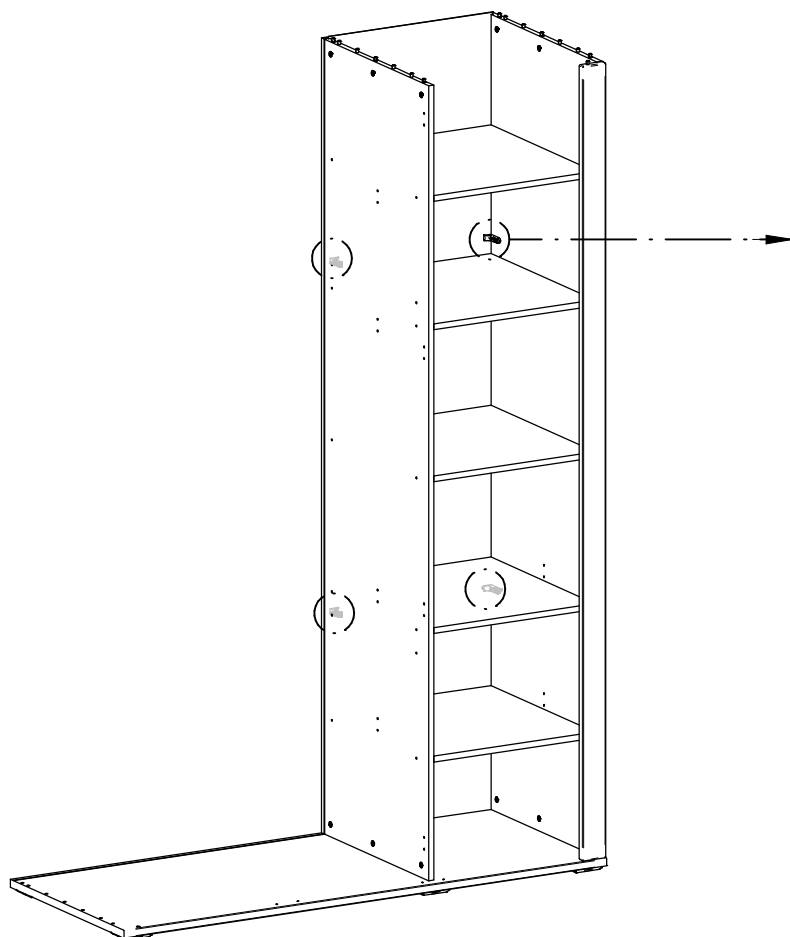



# 9

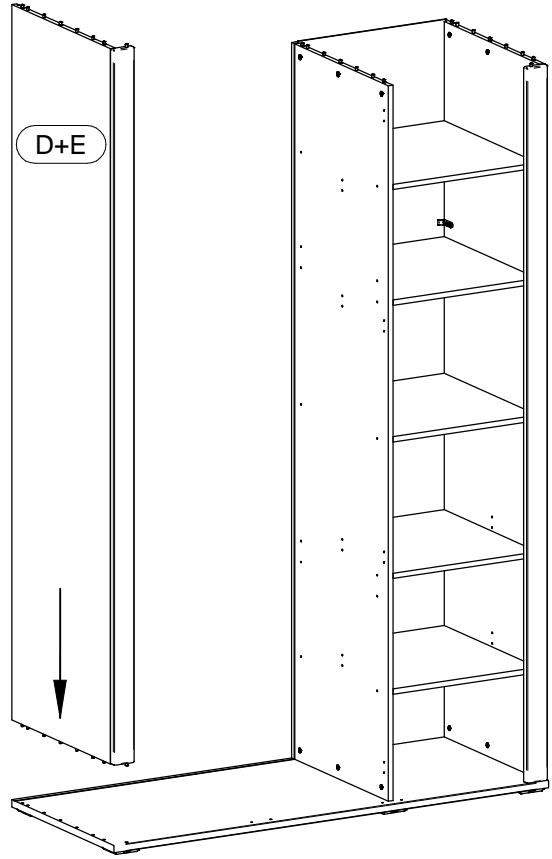
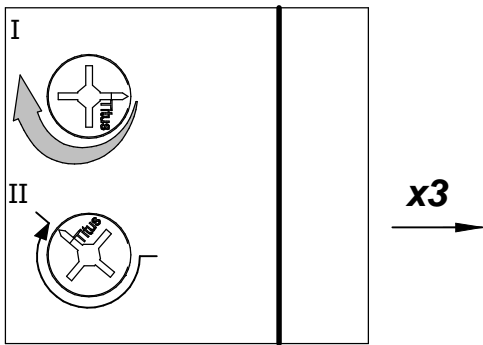

# 10

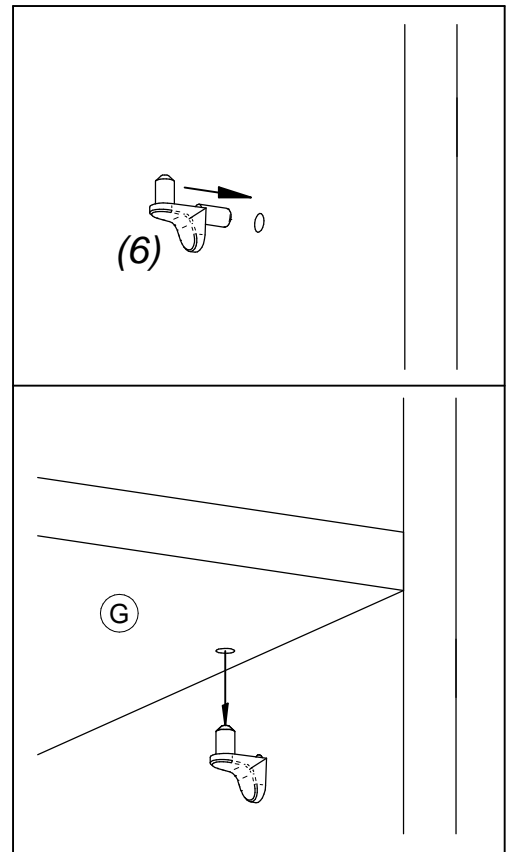
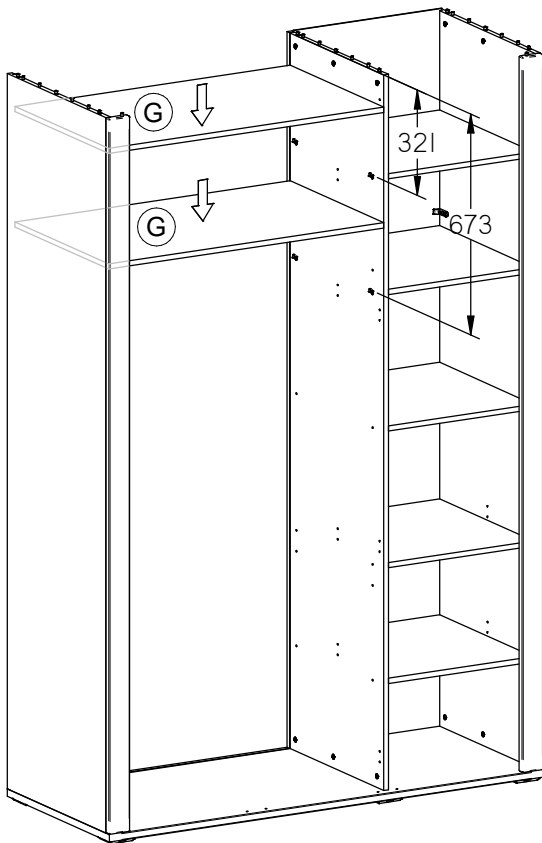

# 11

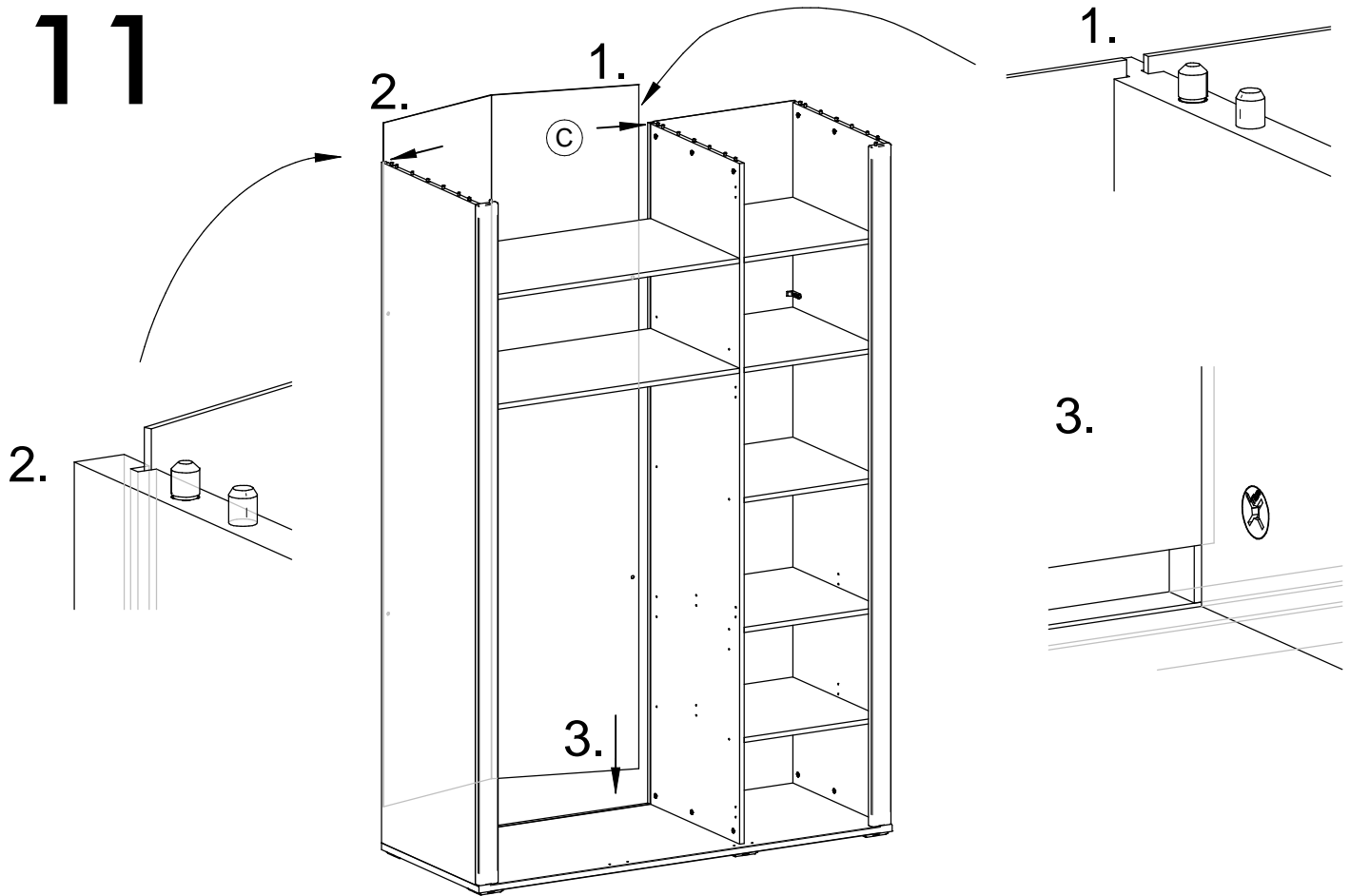

# 12

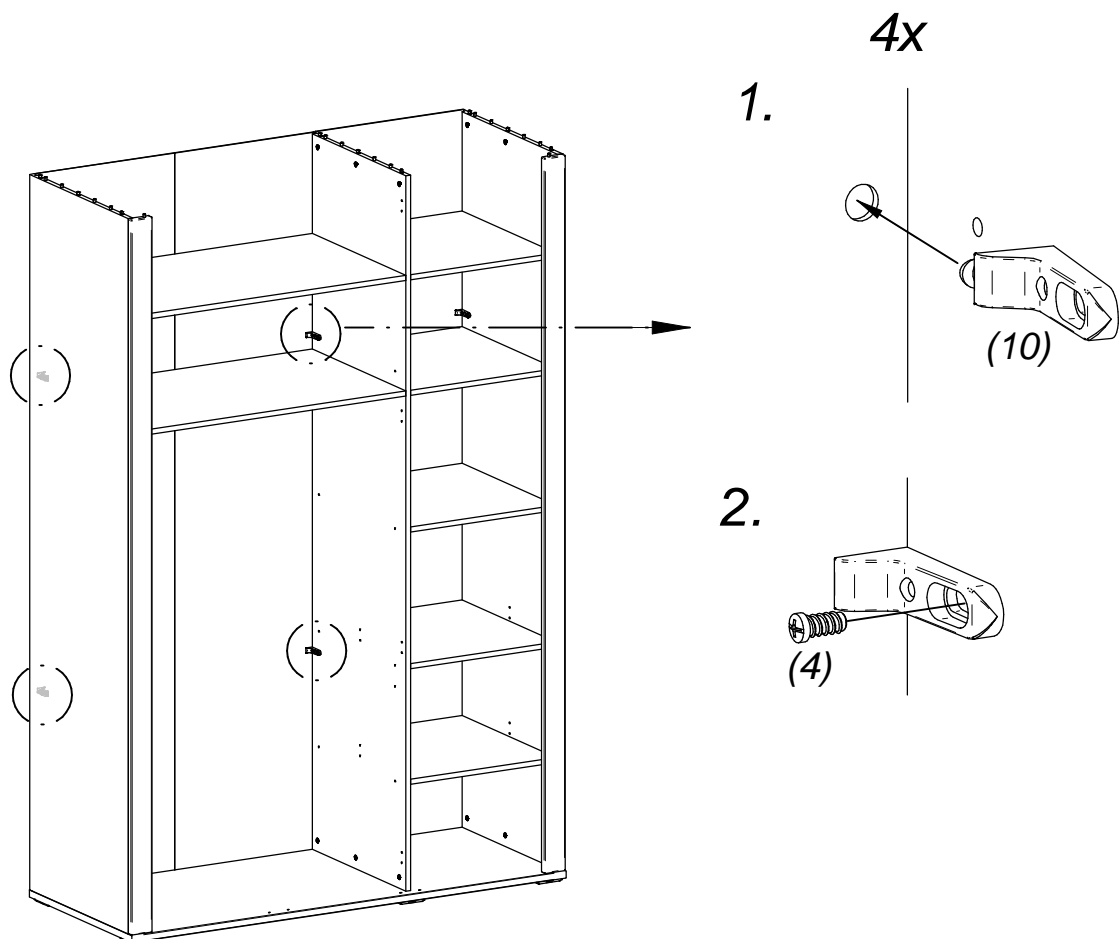

# 13

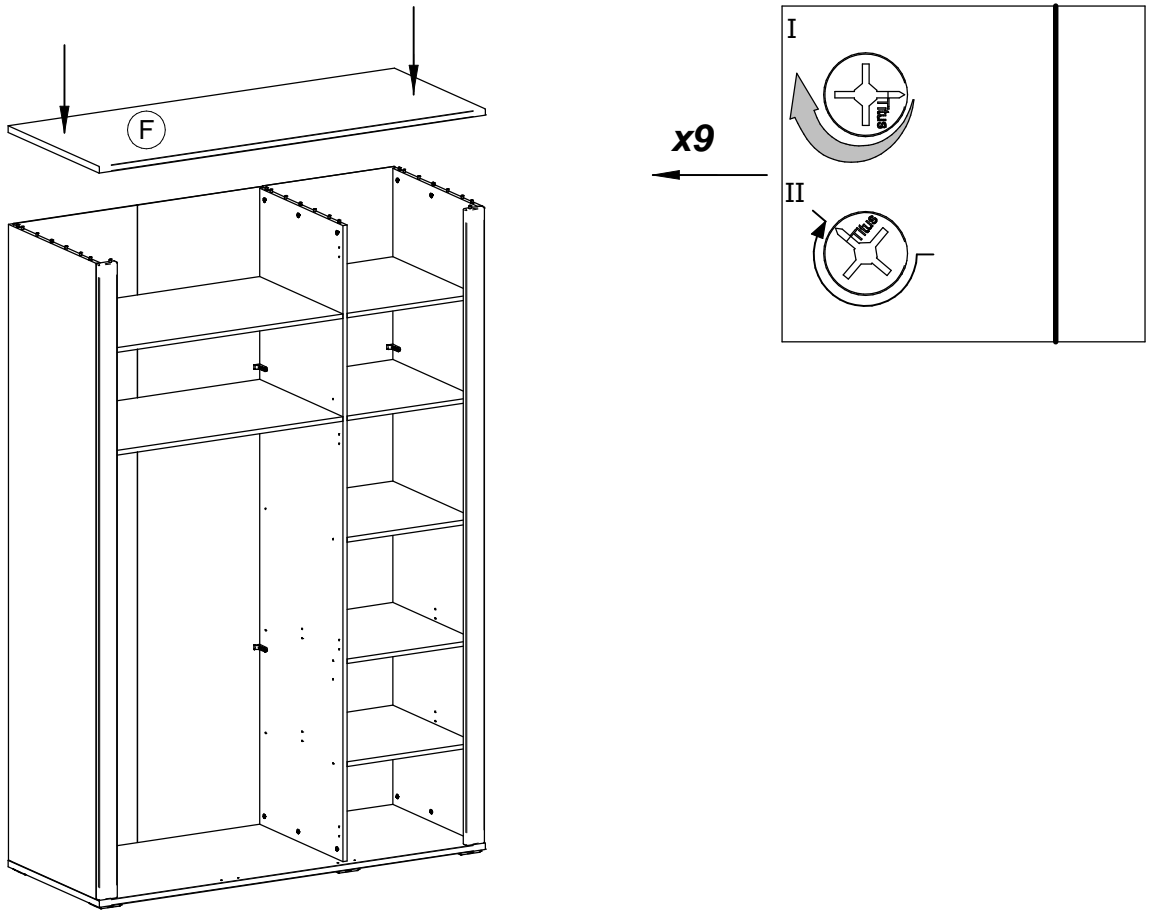

# 14

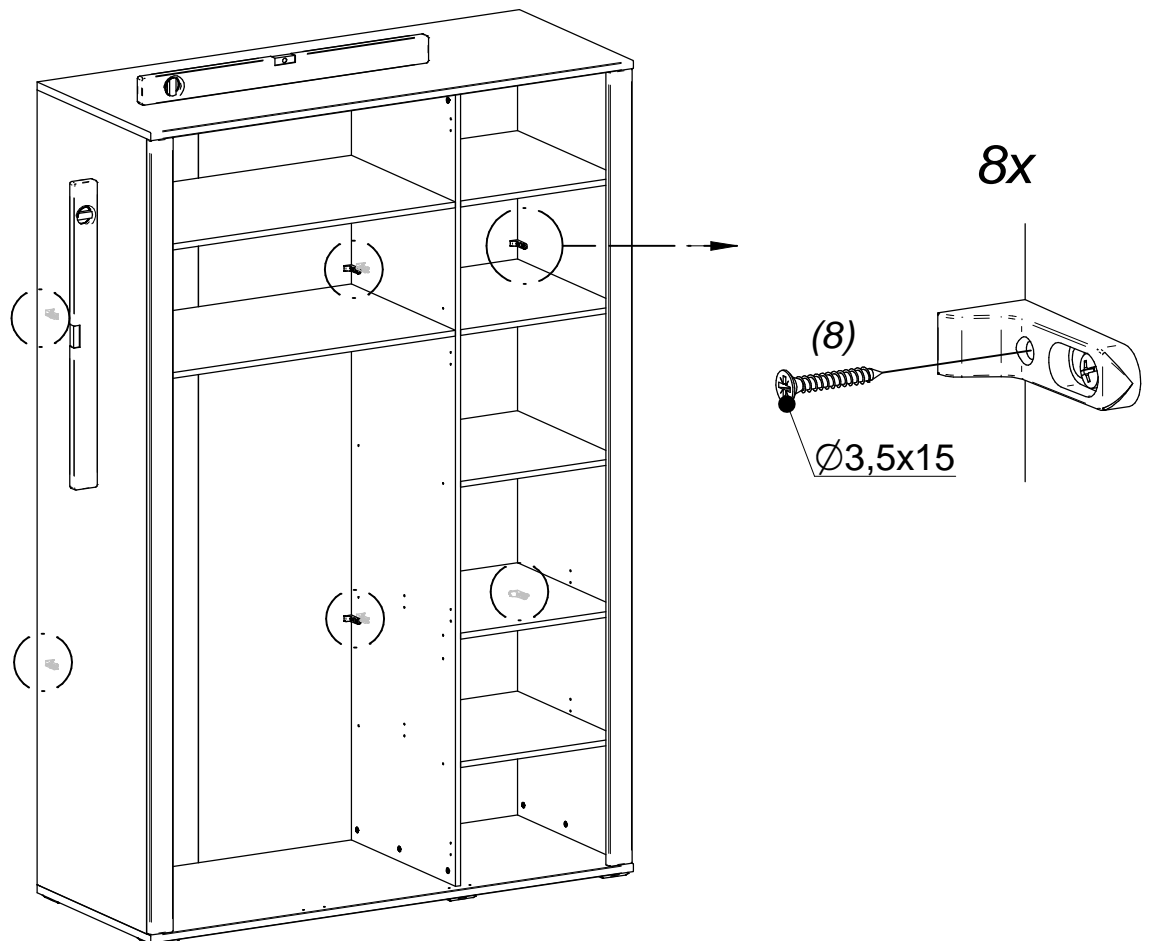

# 15

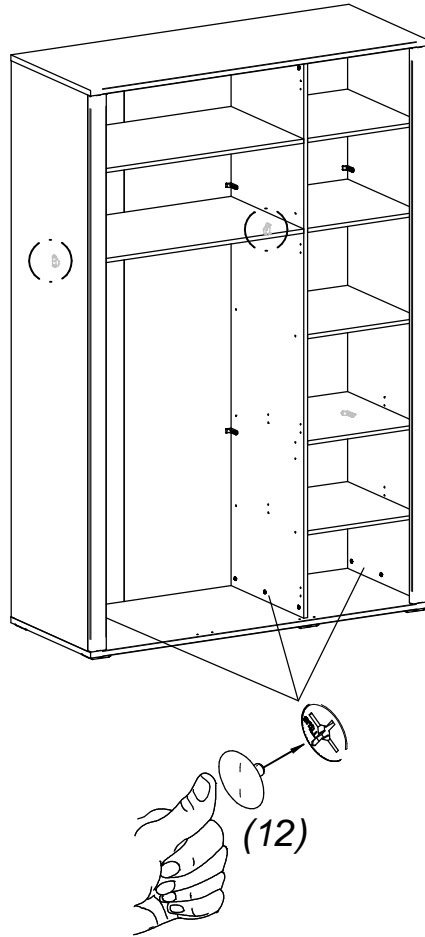

4x

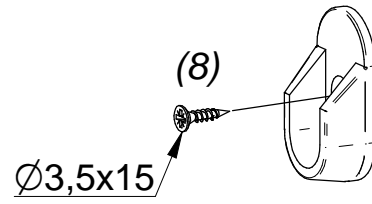
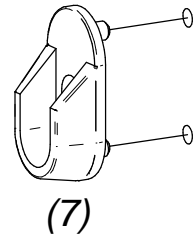

# 16

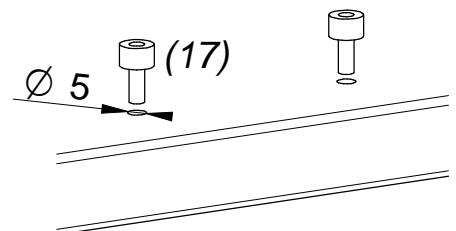
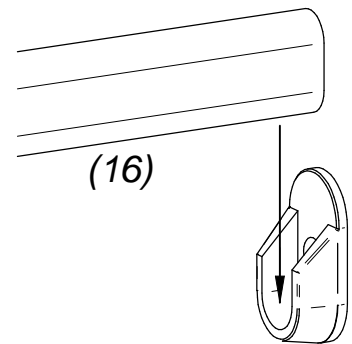
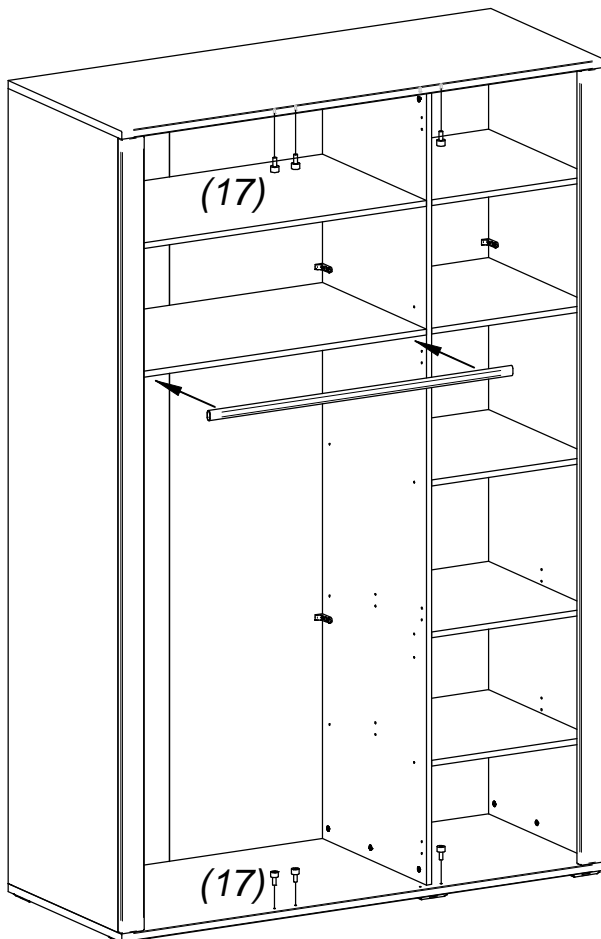

# 17

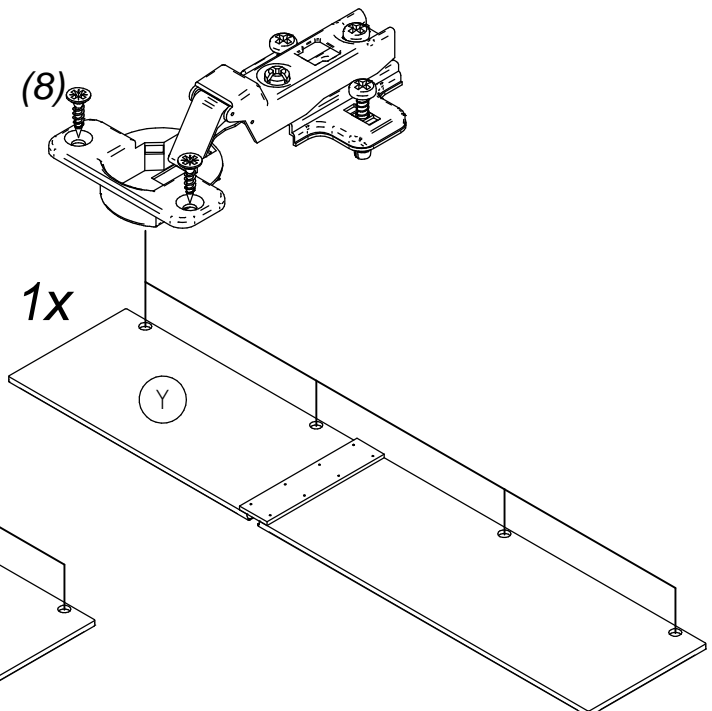
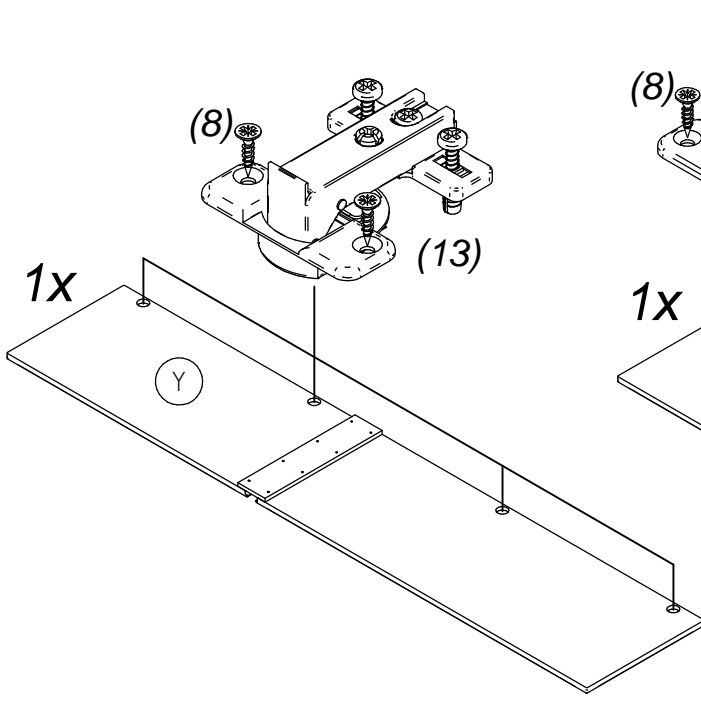
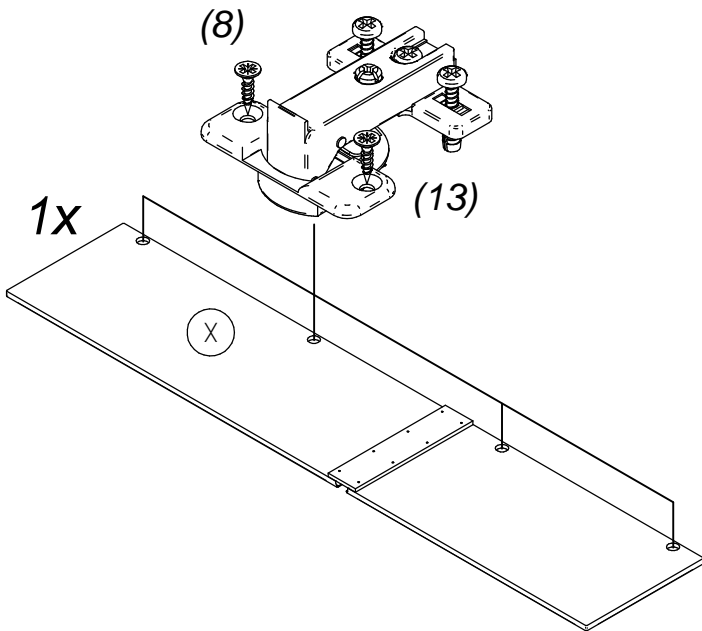
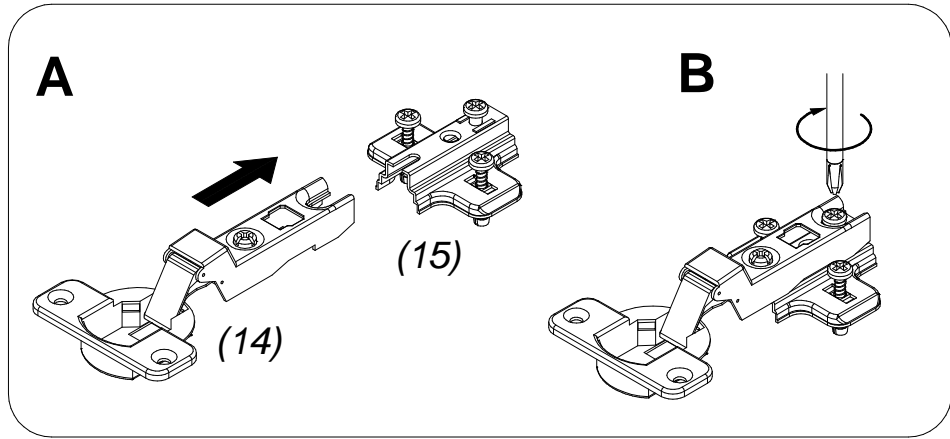

# 18

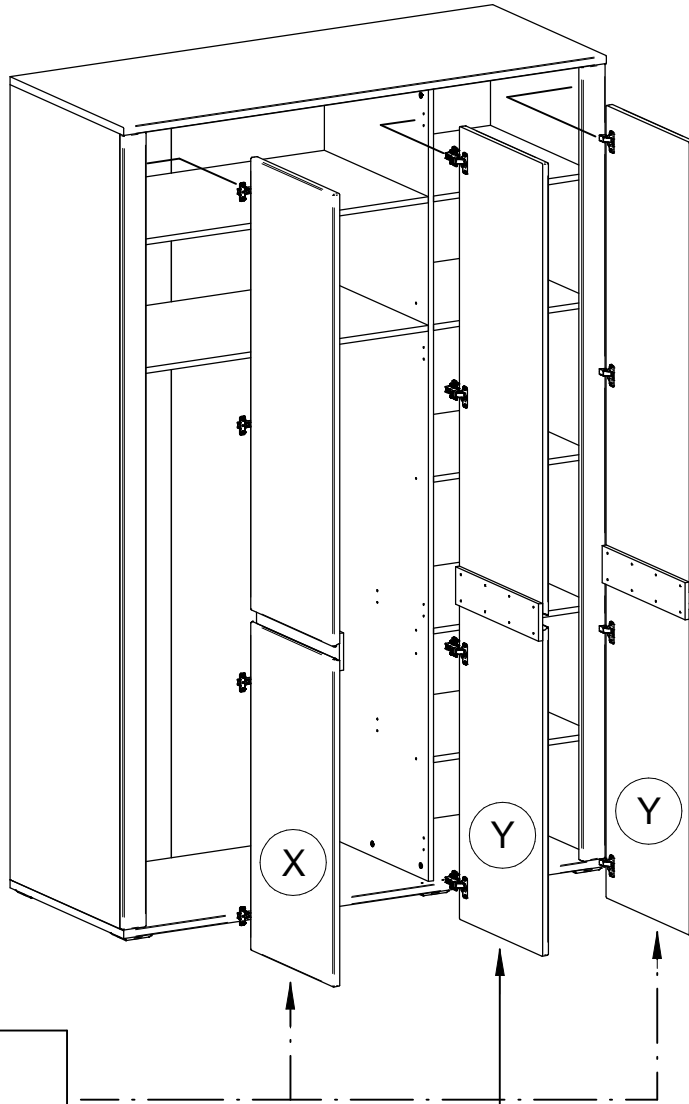

**I.**

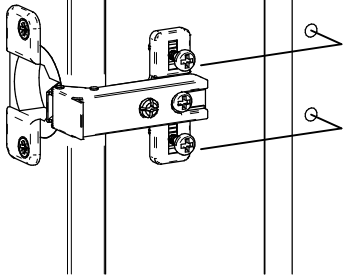

**II.**

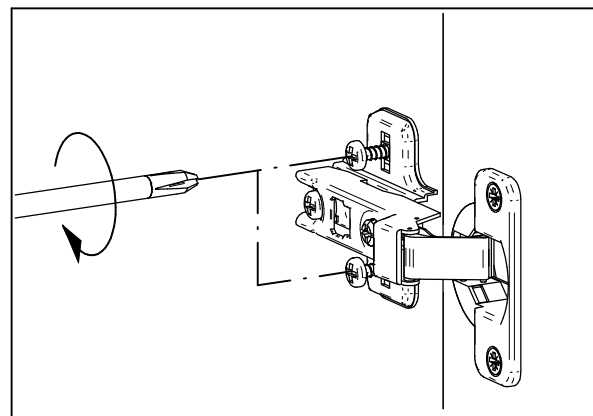
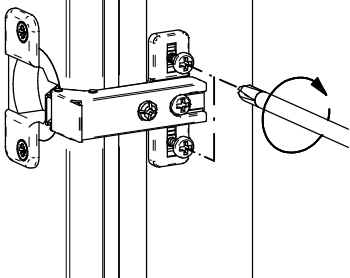

# 19

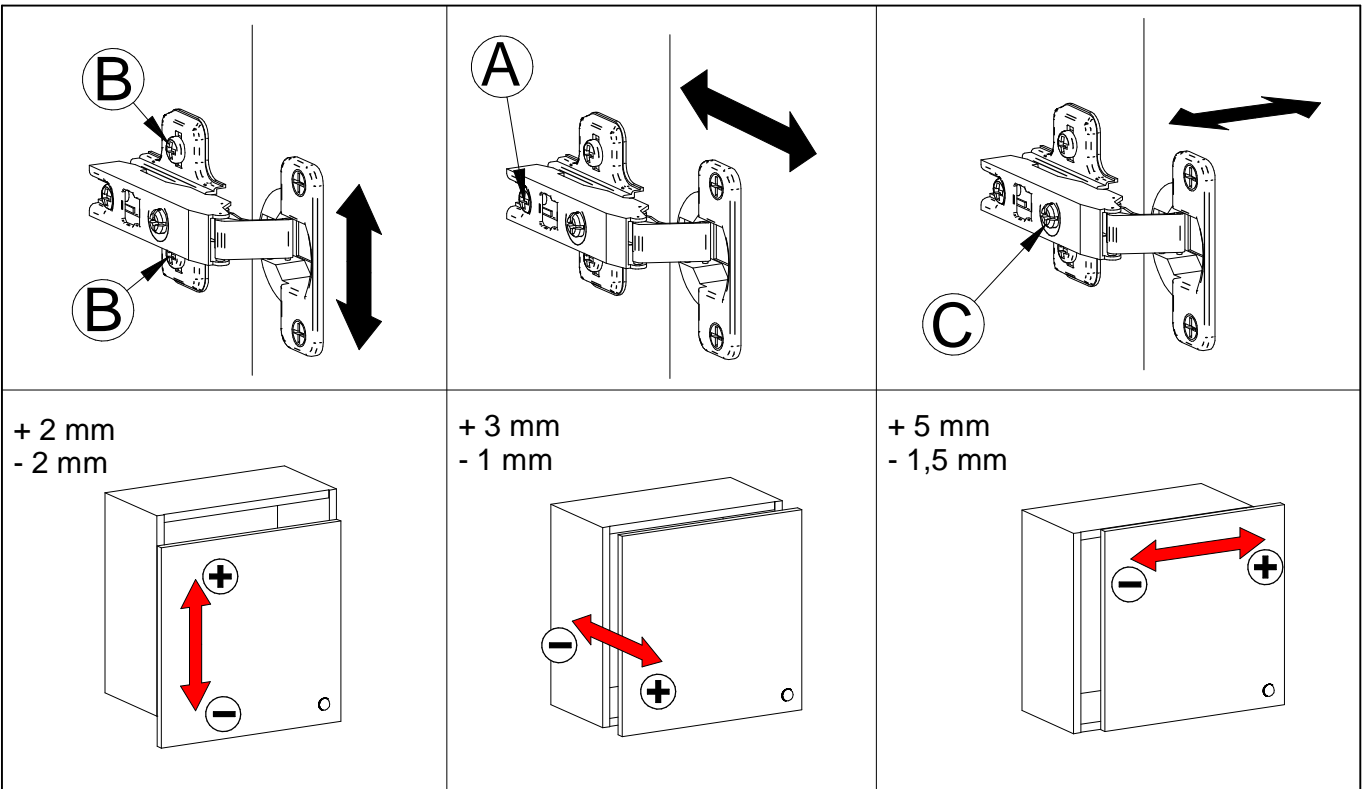
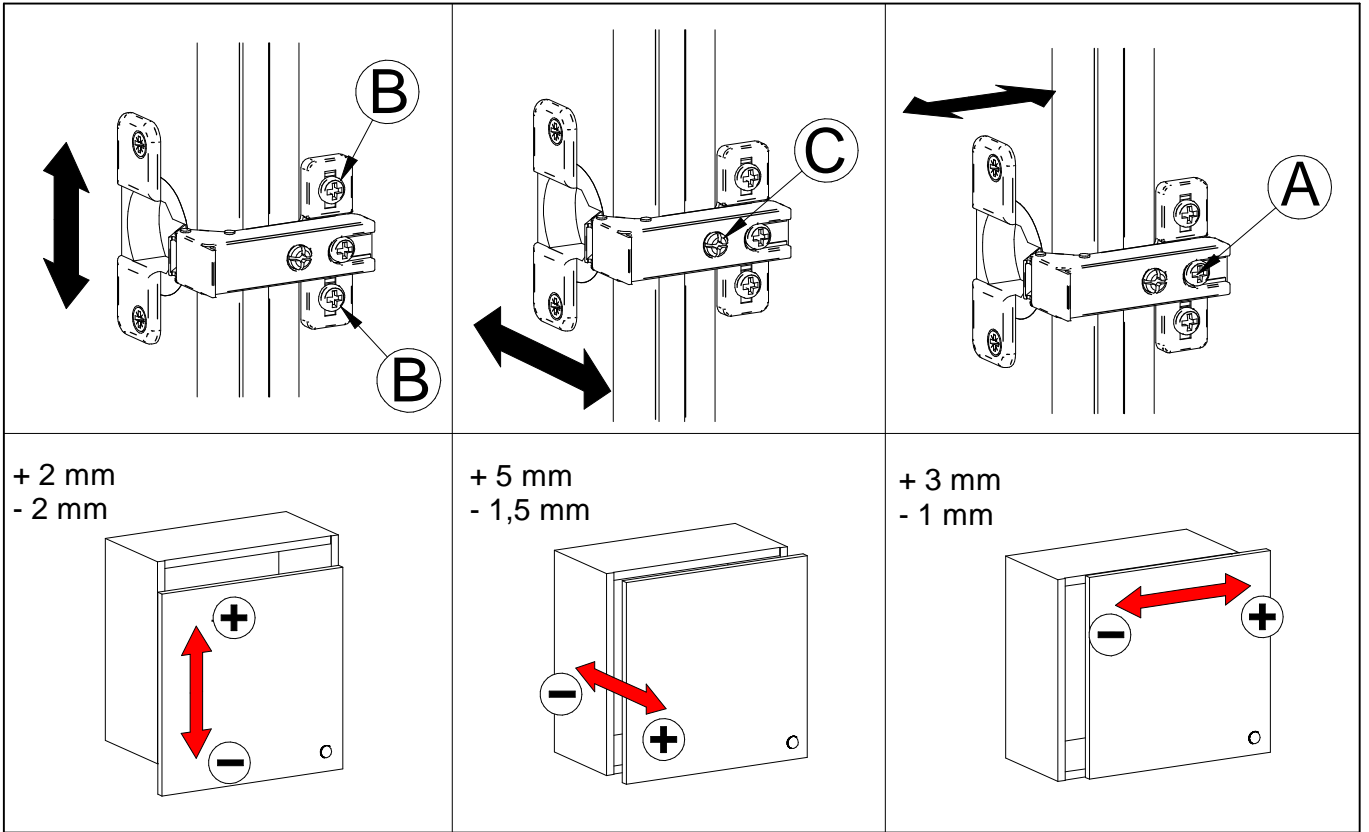

# 20

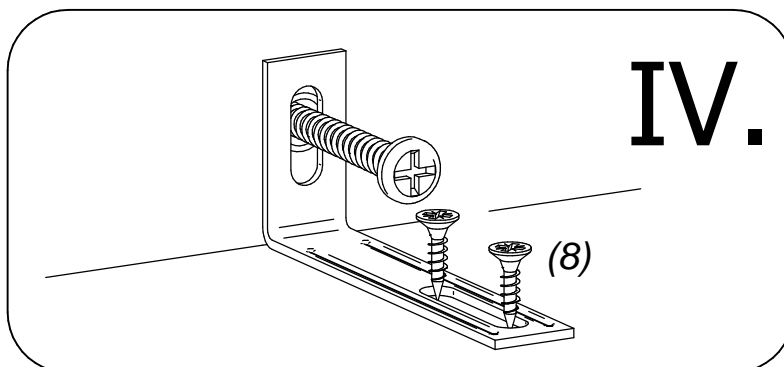
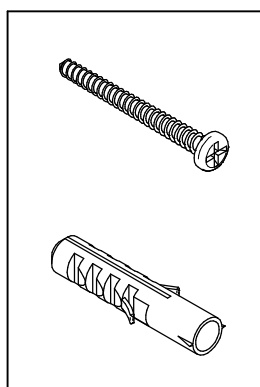
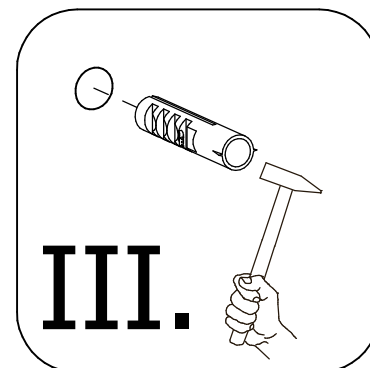
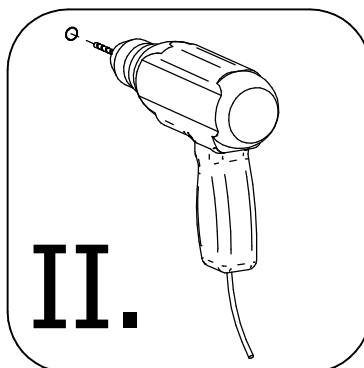
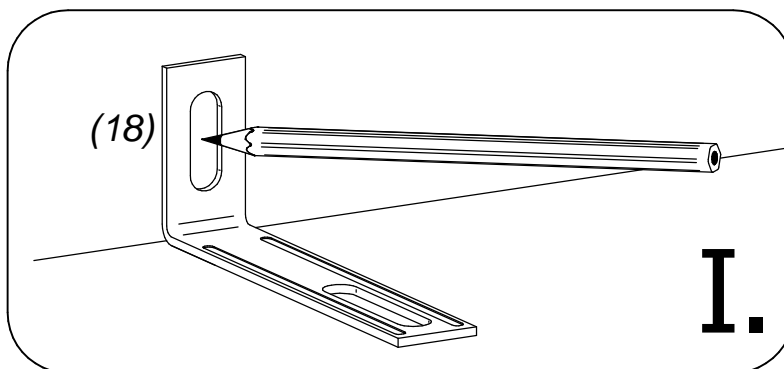
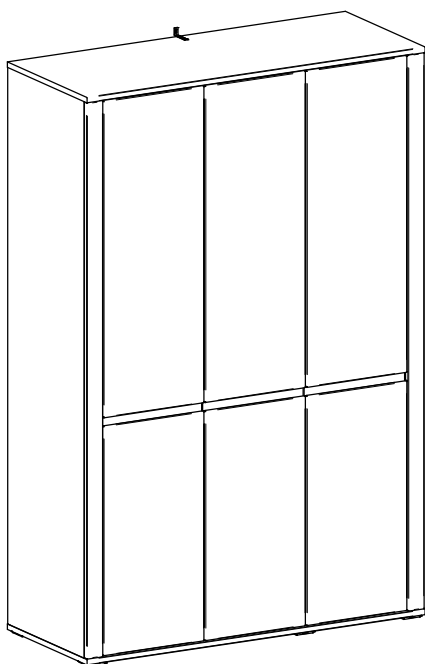
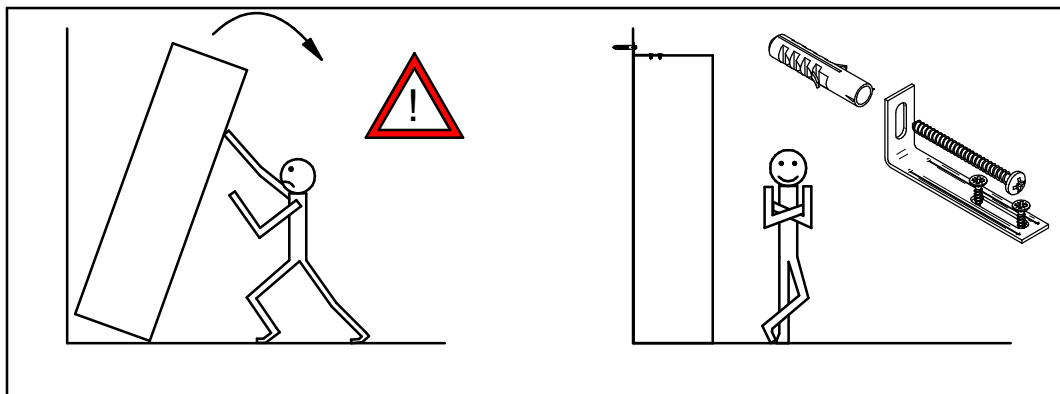

Wenn Möbelstücke umkippen, können ernste oder lebensgefährliche Verletzungen durch Einklemmen die Folge sein. Um zu verhindern, dass das Möbelstück umkippt, muss es fest an der Wand verankert werden. Beschläge für die Wandbefestigung sind nicht beige packt, da sie von der jeweiligen Wandbeschaffenheit abhängig sind. Befestigungsbeschläge benutzen, die für die heimischen Wände geeignet sind. Bei diesbezüglichen Fragen den örtlichen Fachhandel zu Rate ziehen.

Prevrhnutie nábytku môže spôsobiť vážne či smrteľné zranenia. Aby sa zabránilo prevrhnutiu nábytku, upevnite ho ku stene. Upevňovací materiál nie je súčasťou balenia, pretože na každý materiál steny je potrebné použiť iný typ skrutky a hmoždinky. Použite taký upevňovací materiál, ktorý je vhodný na konkrétny typ steny u vás doma. V prípade potreby sa poraďte s odborníkom.