

12/004-1

### POINT 54

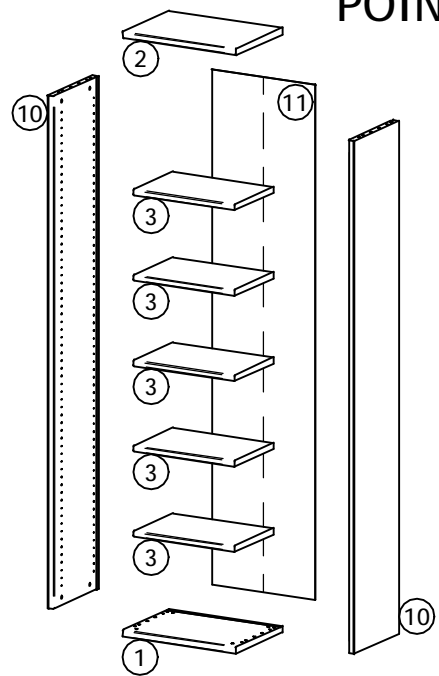

D	x14	EA	$\varnothing 10 \times 45$ x16	G	$\varnothing 5$ x20	I	x4
JD	$\varnothing 4 \times 25$ x14	L	$\varnothing 15$ x8	M	$\varnothing 8$ x8		
		KD	$\varnothing 15$ x8			Z	$\varnothing 5/2 \times 28$ x4

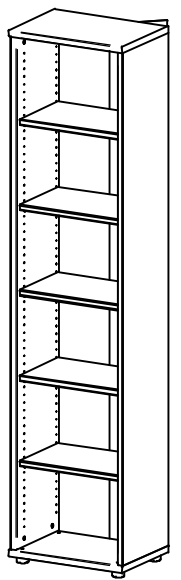
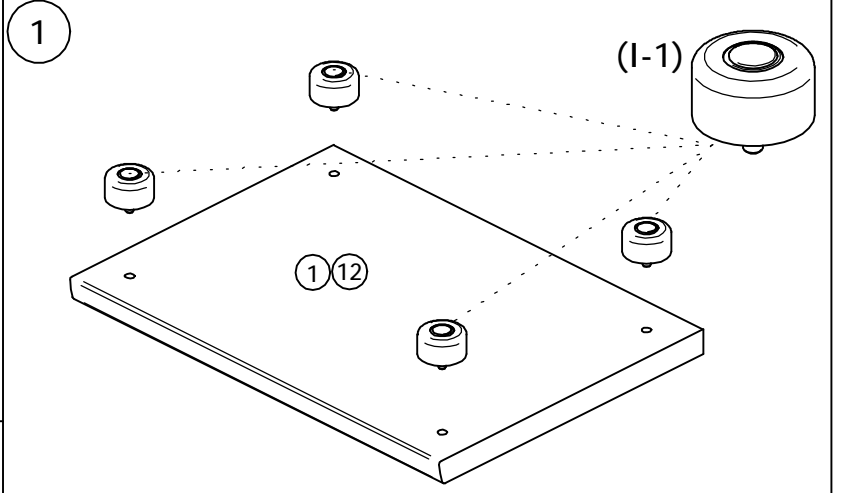
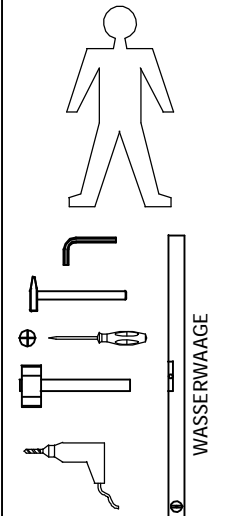

### POINT 84

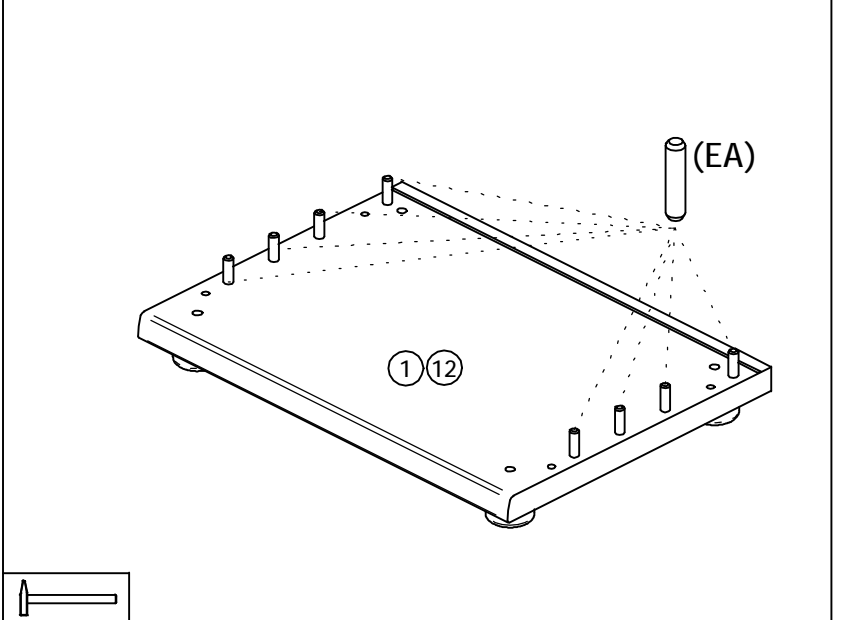
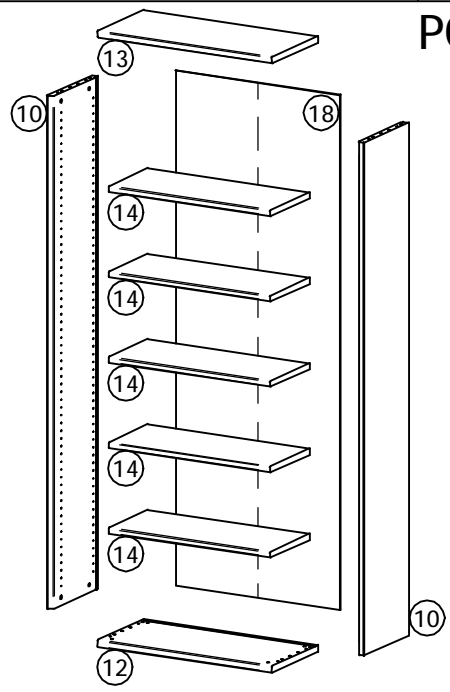
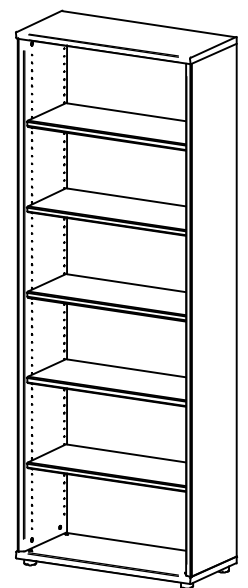

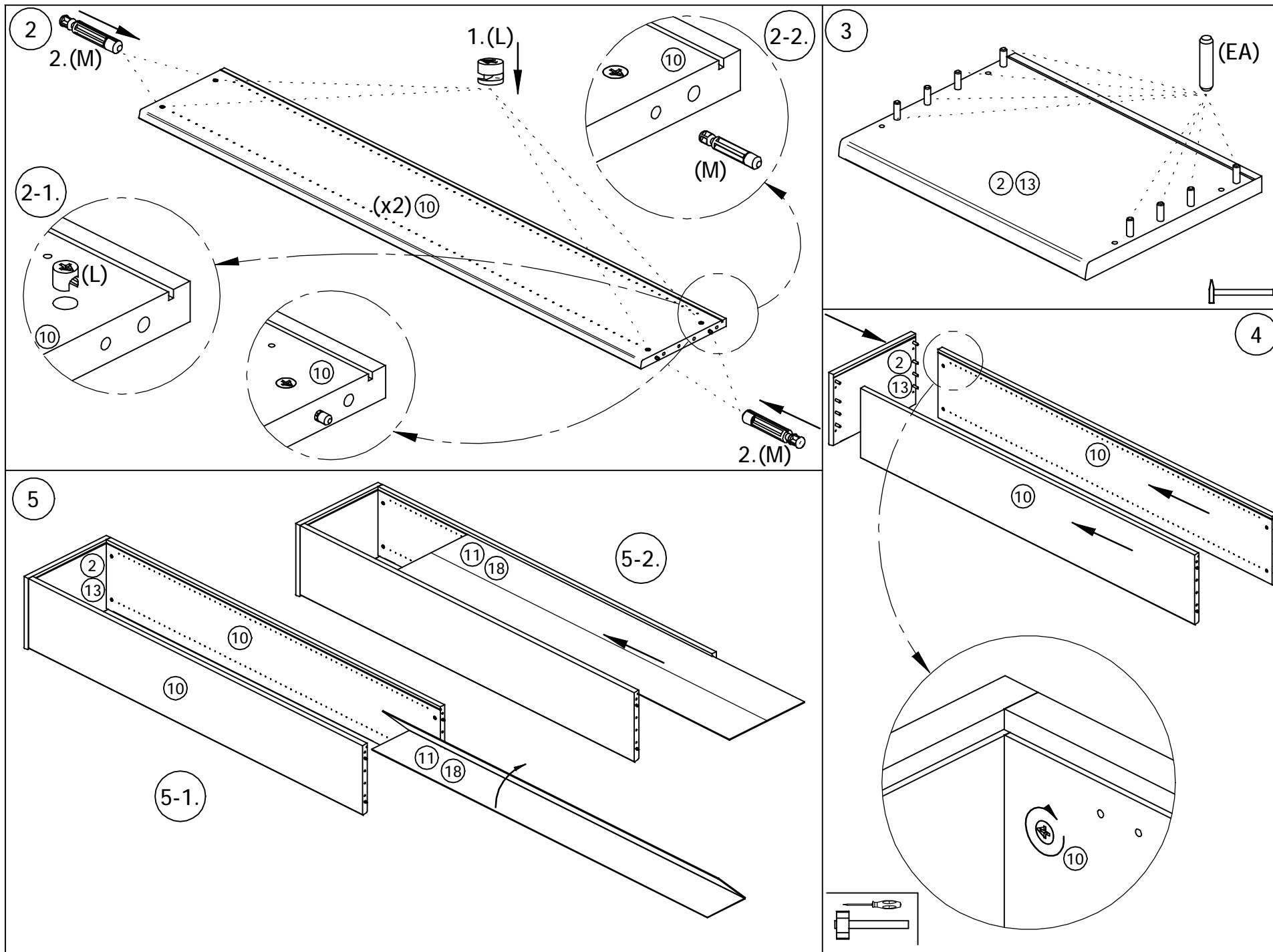

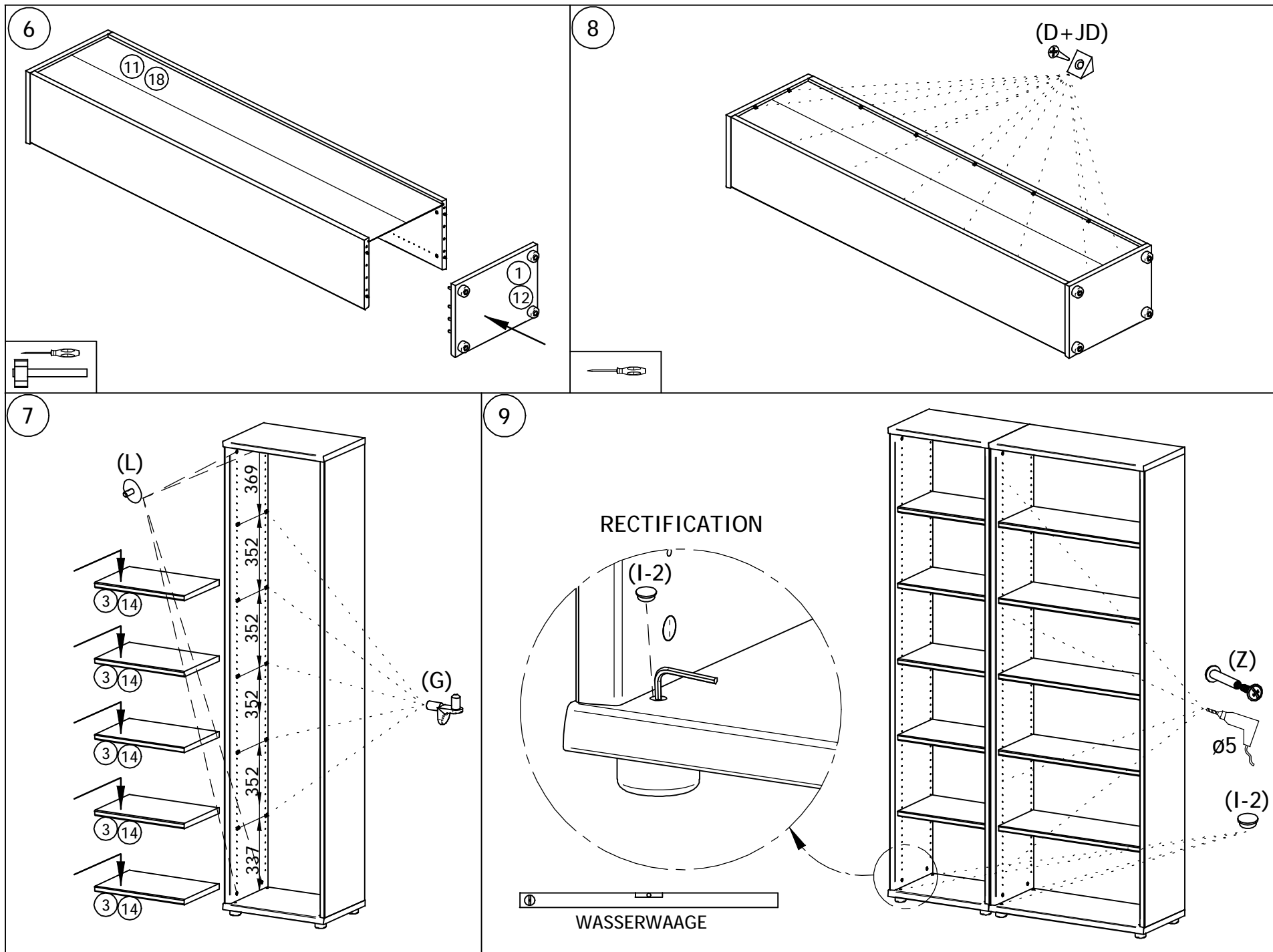

## POINT T83



AA



x2

B

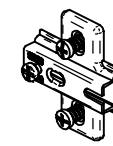

x8

C

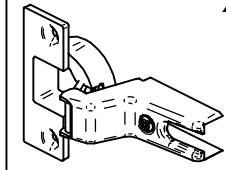

x8

KE



x4

JA

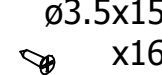

AC

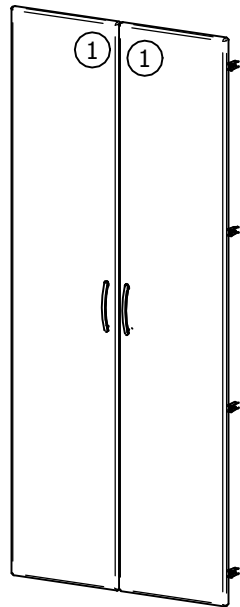
M4x25  
x4

1

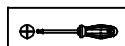
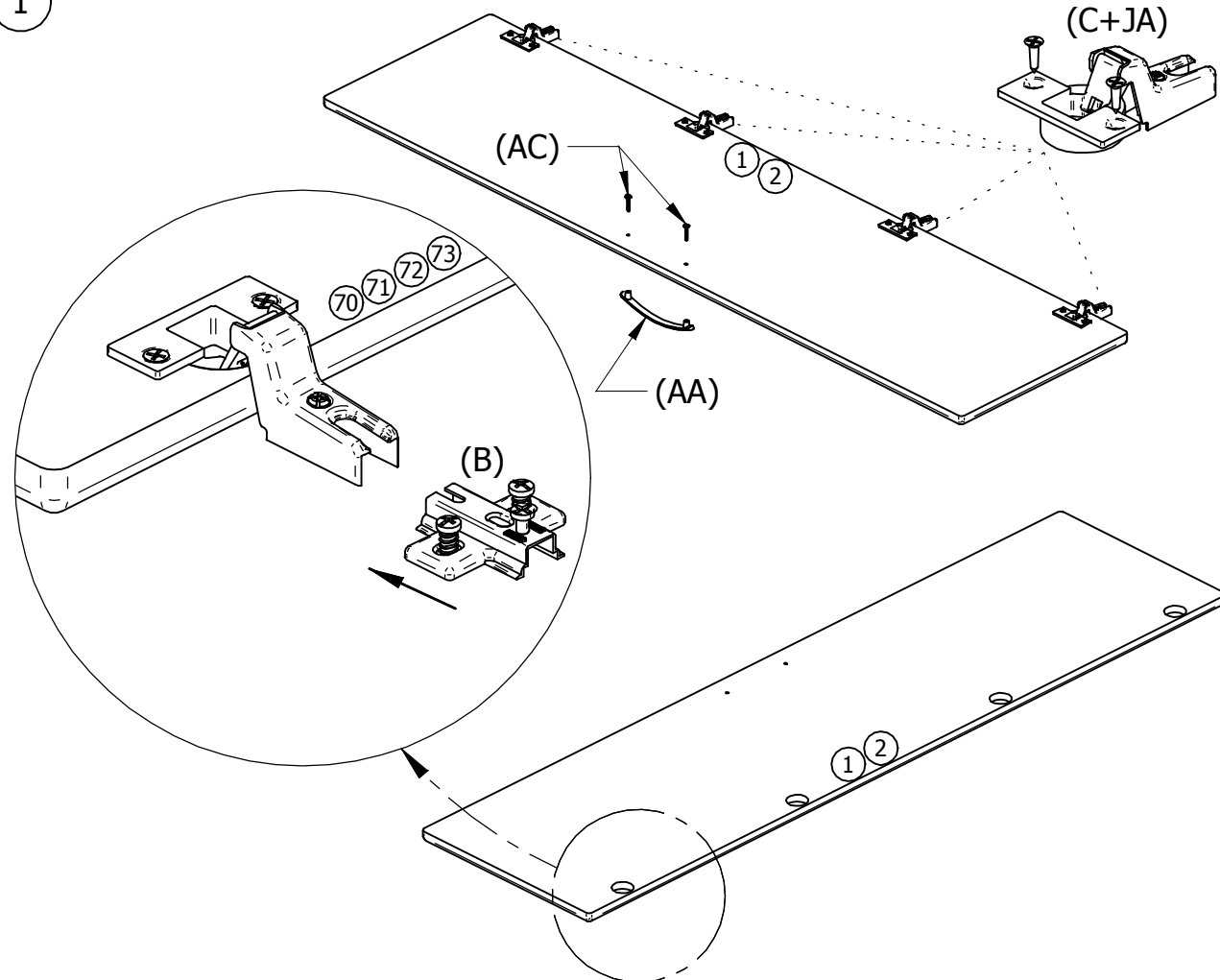

2

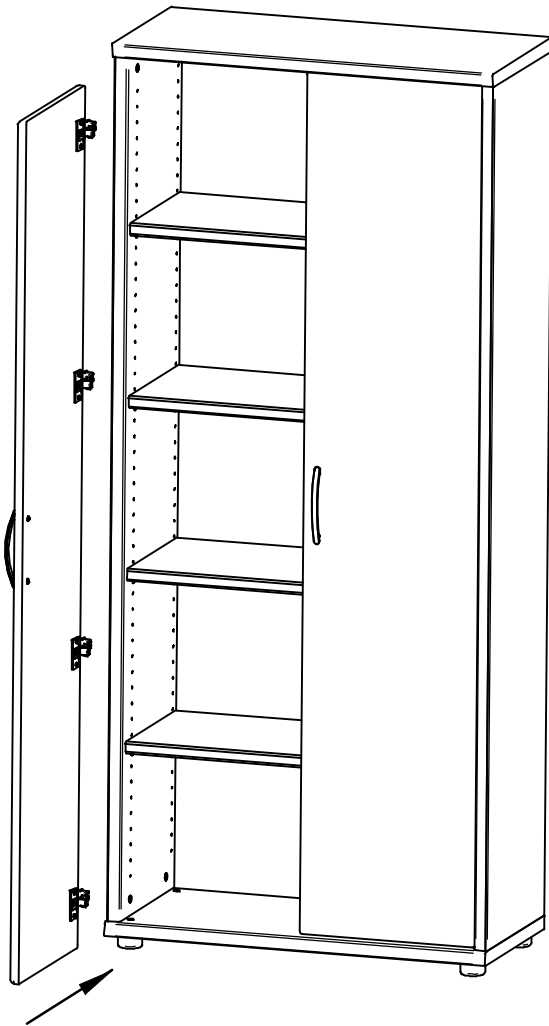
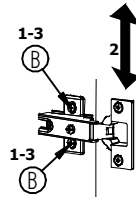
**NASTAVENIE DVERI / EINSTELLUNG VON TUREN**

- 1: SKRUTKU B POVOLIT  
DIE SCHRAUBEN B LOSEN
- 2: DVERE VYSKOVO NASTAVIT  
TUR IN DER HOHE JUSTIEREN
- 3: SKRUTKU B DOTIAHNUT  
DIE SCHRAUBEN B ANZIEHEN

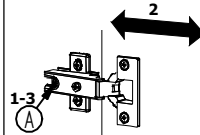

- 1: SKRUTKU A POVOLIT  
DIE SCHRAUBEN A LOSEN
- 2: DVERE HLBKOVO NASTAVIT  
TUR IN DER TIEFE JUSTIEREN
- 3: SKRUTKU A DOTIAHNUT  
SCHRAUBEN A ANZIEHEN

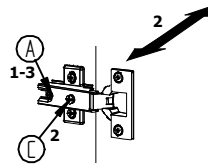

- 1: SKRUTKU A POVOLIT  
DIE SCHRAUBEN A LOSEN
- 2: DVERE STRANOVO SKRUTKOU C  
NASTAVIT  
TUR SEITLIGS MIT SCHRAUBE C  
JUSTIEREN
- 3: SKRUTKU A DOTIAHNUT  
SCHRAUBE A ANZIEHEN

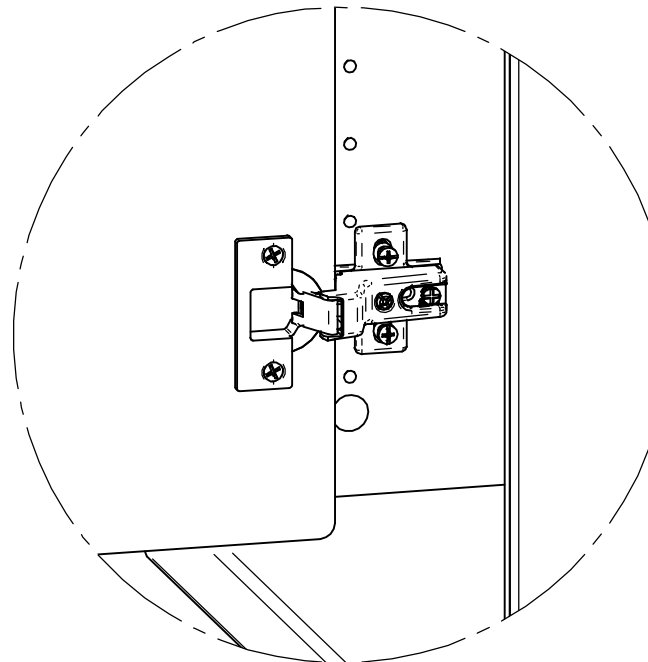

(KE)

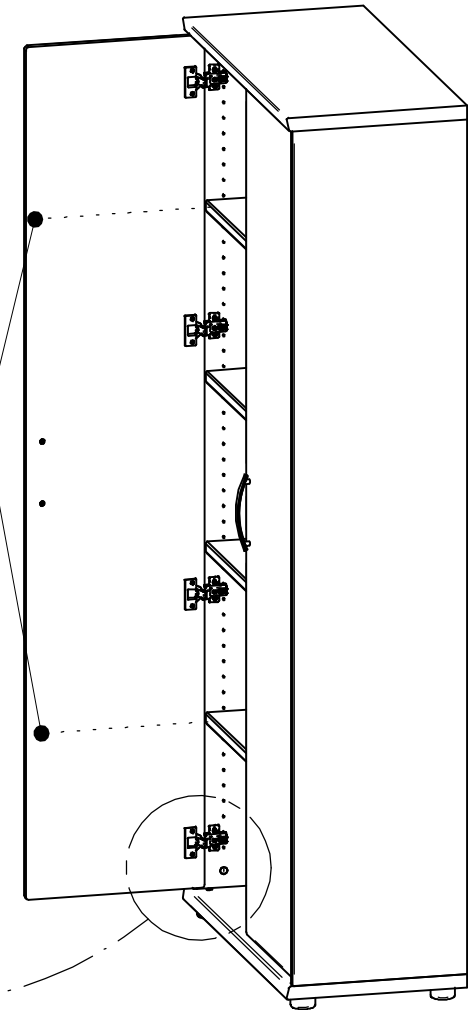

3

