

12/003-1

POINT 53

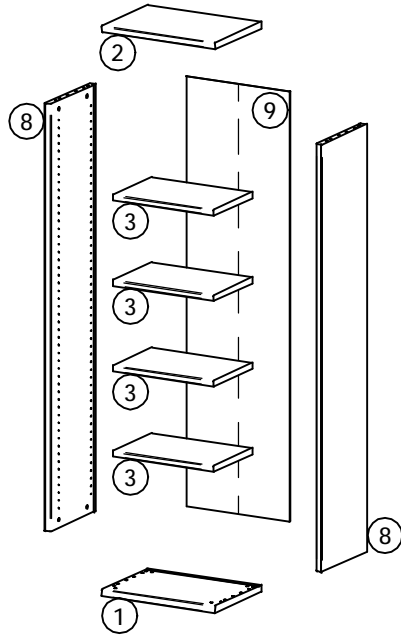

D	x12	EA	$\varnothing 10 \times 45$ x16	G	$\varnothing 5$ x16	I	x4
JD	$\varnothing 4 \times 25$ x12	L	$\varnothing 15$ x8	M	$\varnothing 8$ x8	Z	$\varnothing 5/2 \times 28$ x4
		KD	$\varnothing 15$ x8				

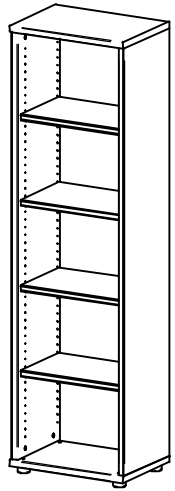
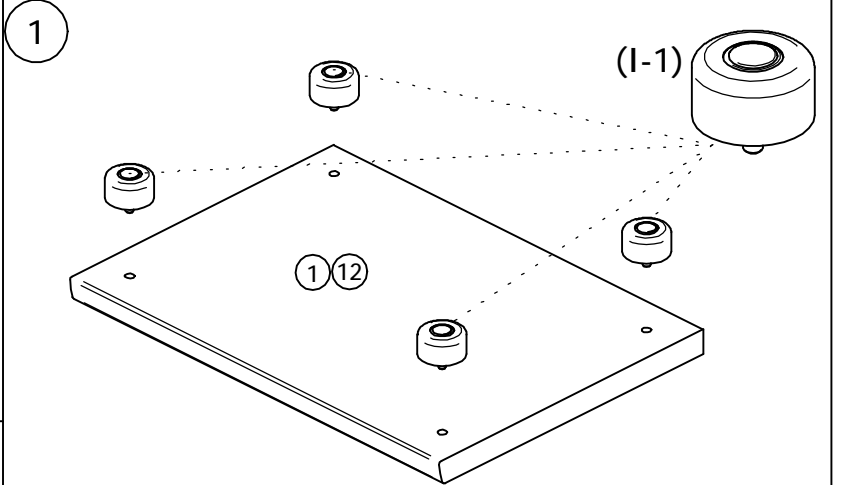
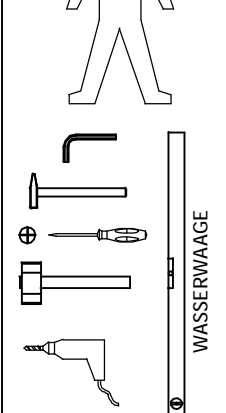

POINT 83

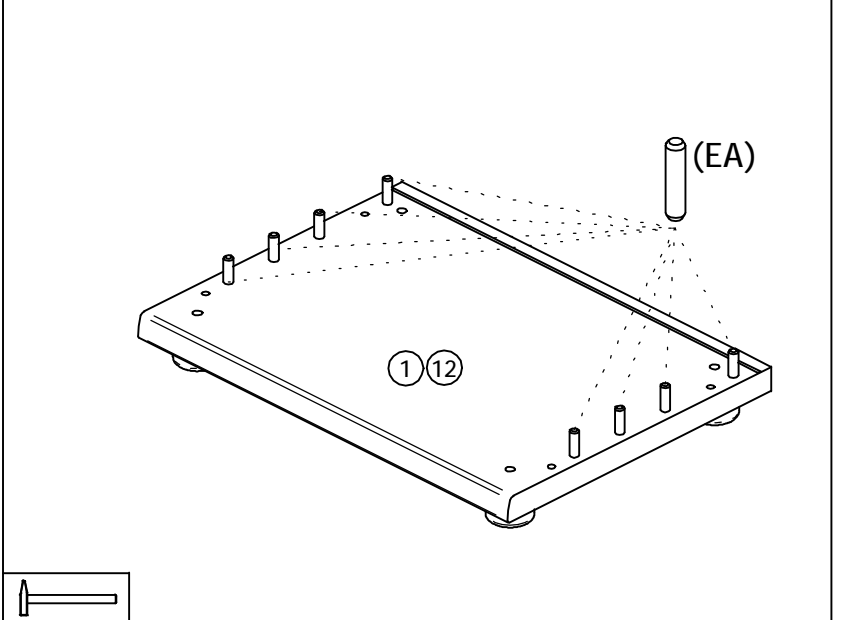
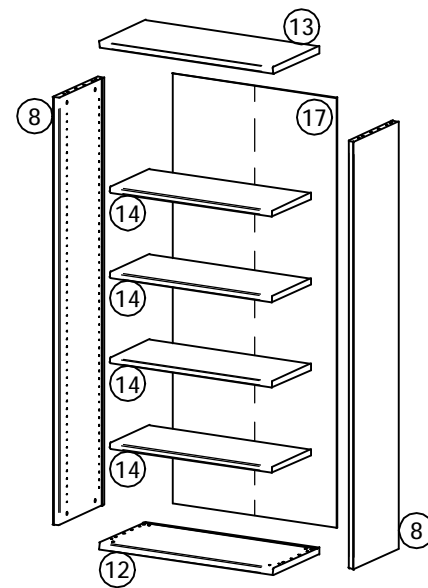
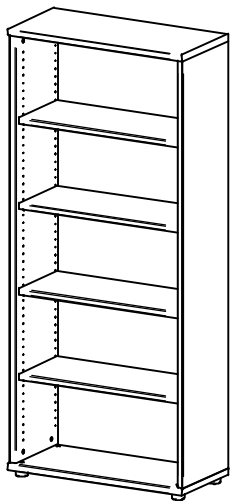

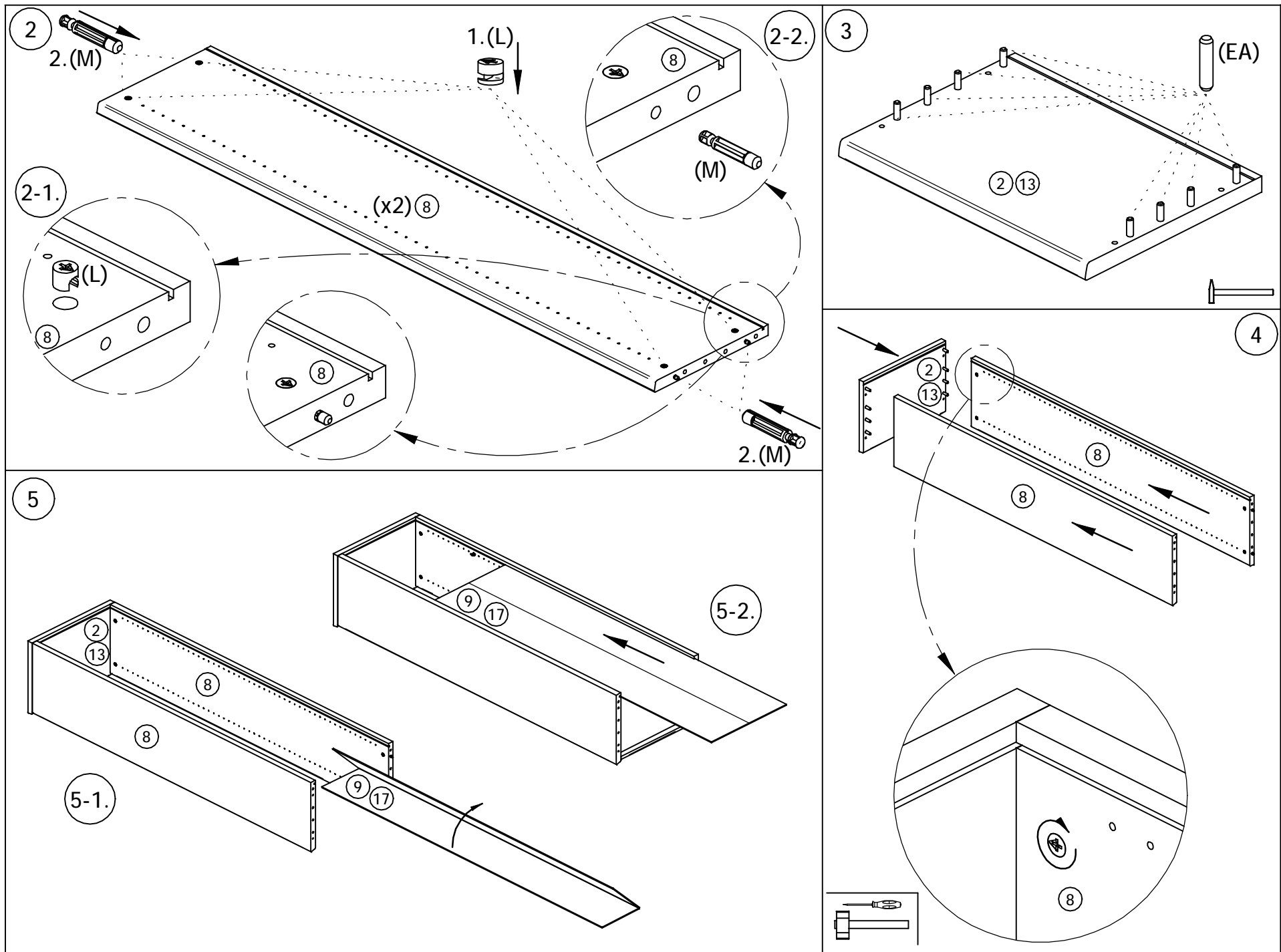

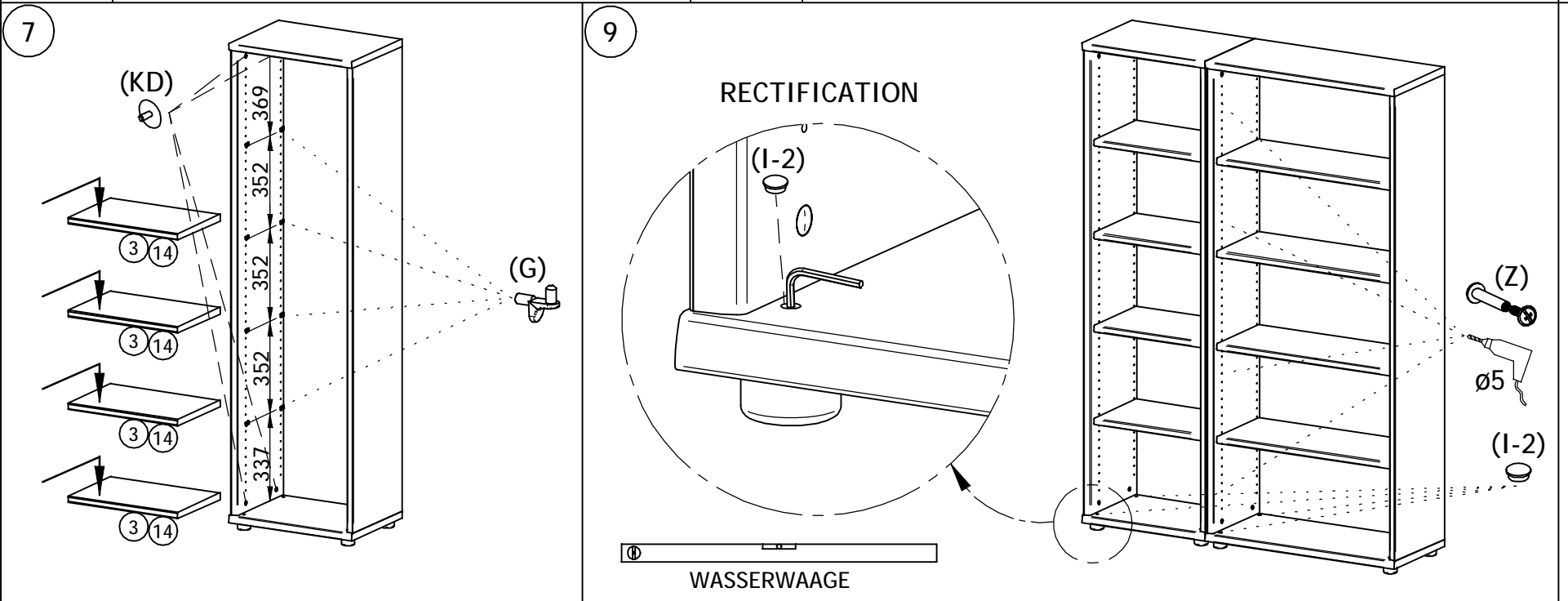
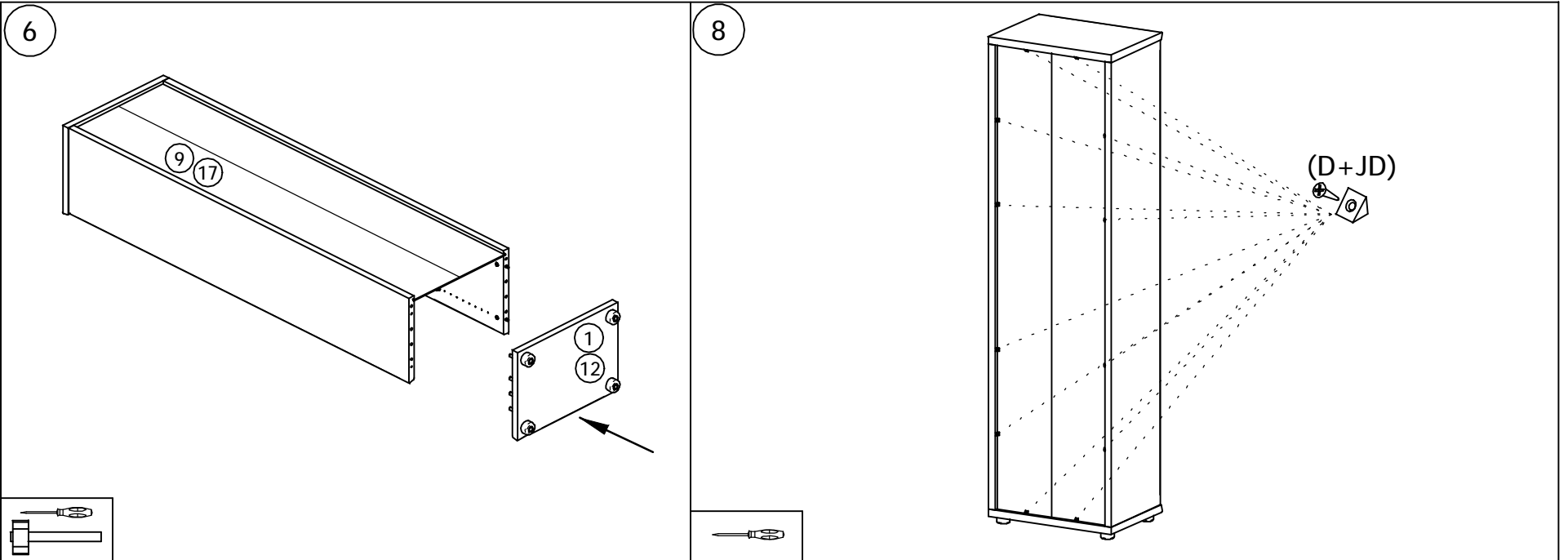

POINT T80
 POINT T801
 POINT T81

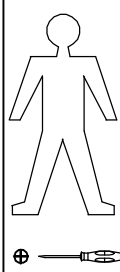

AA		x2	B		x4	C		x4
KE		x4	JA		ø3.5x15 x8	AC		M4x25 x4

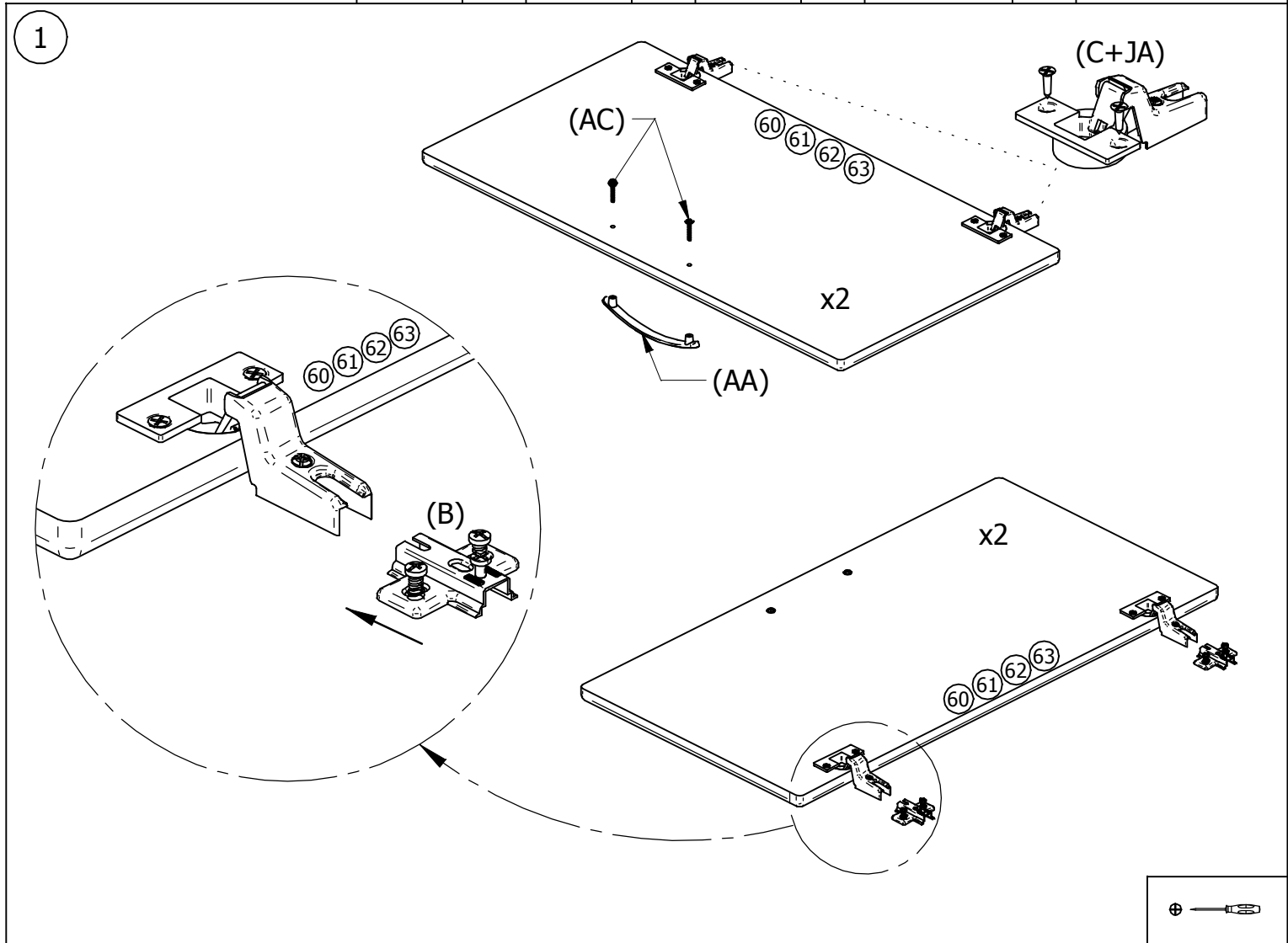
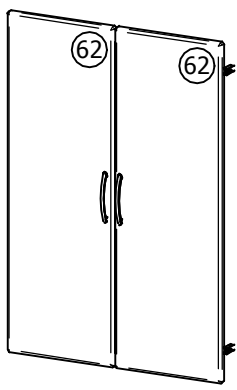
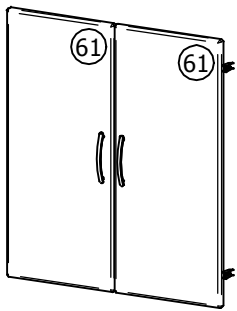
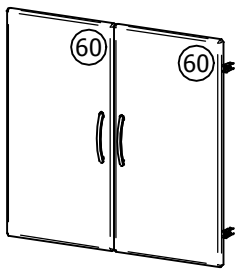

2

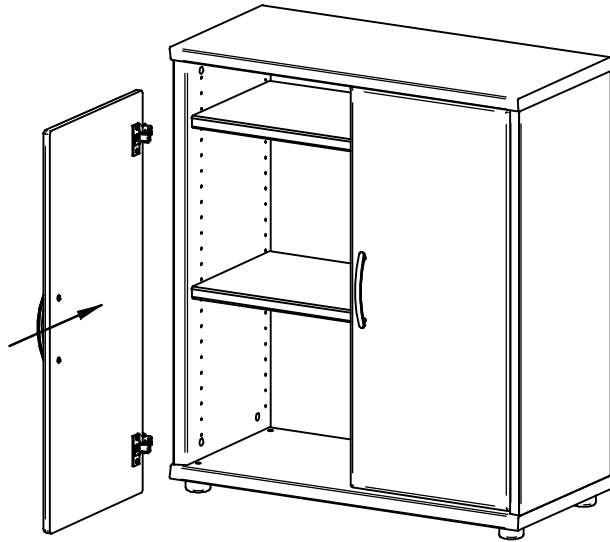

3

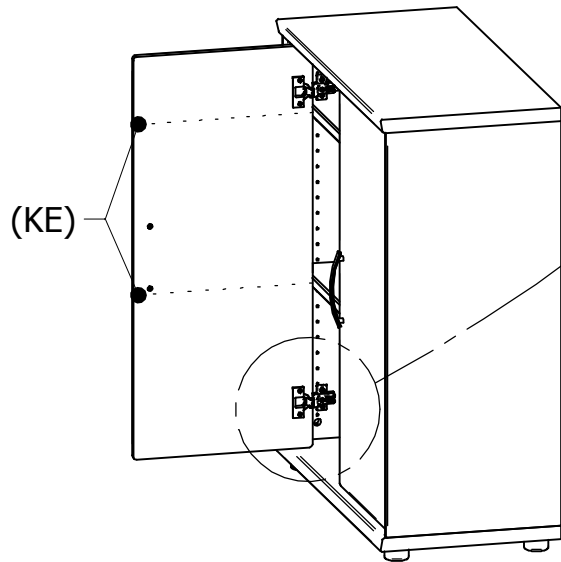
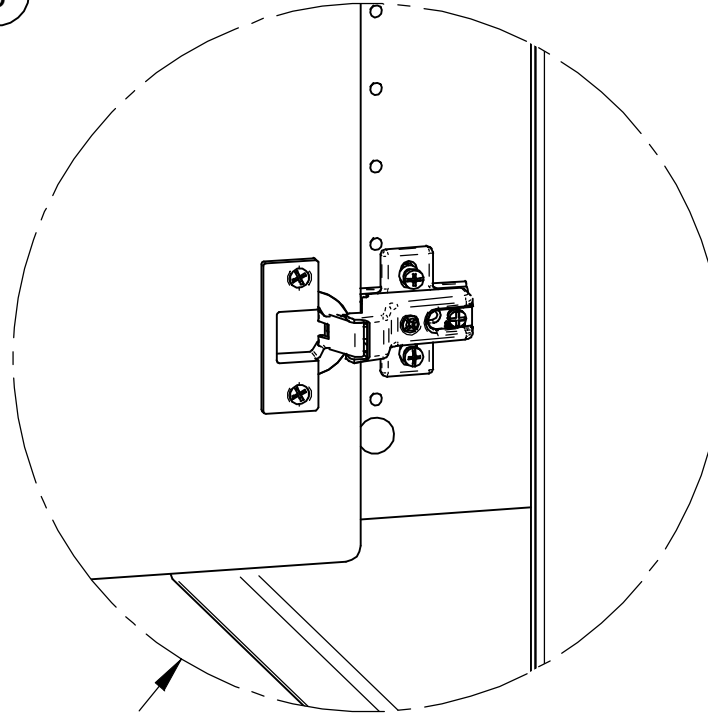
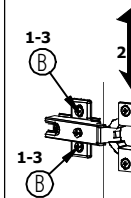
NASTAVENIE DVERI / EINSTELLUNG VON TUREN

- 1: SKRUTKU B POVOLIT
DIE SCHRAUBEN B LOSEN
- 2: DVERE VYSKOVO NASTAVIT
TUR IN DER HOHE JUSTIEREN
- 3: SKRUTKU B DOTIAHNUT
DIE SCHRAUBEN B ANZIEHEN

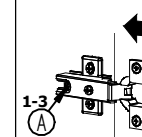

- 1: SKRUTKU A POVOLIT
DIE SCHRAUBEN A LOSEN
- 2: DVERE HLBKOVO NASTAVIT
TUR IN DER TIEFE JUSTIEREN
- 3: SKRUTKU A DOTIAHNUT
SCHRAUBEN A ANZIEHEN

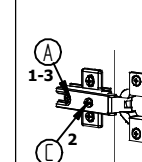

- 1: SKRUTKU A POVOLIT
DIE SCHRAUBEN A LOSEN
- 2: DVERE STRANOVO SKRUTKOU C
NASTAVIT
TUR SEITLIGS MIT SCHRAUBE C
JUSTIEREN
- 3: SKRUTKU A DOTIAHNUT
SCHRAUBE A ANZIEHEN

