

### POINT 52

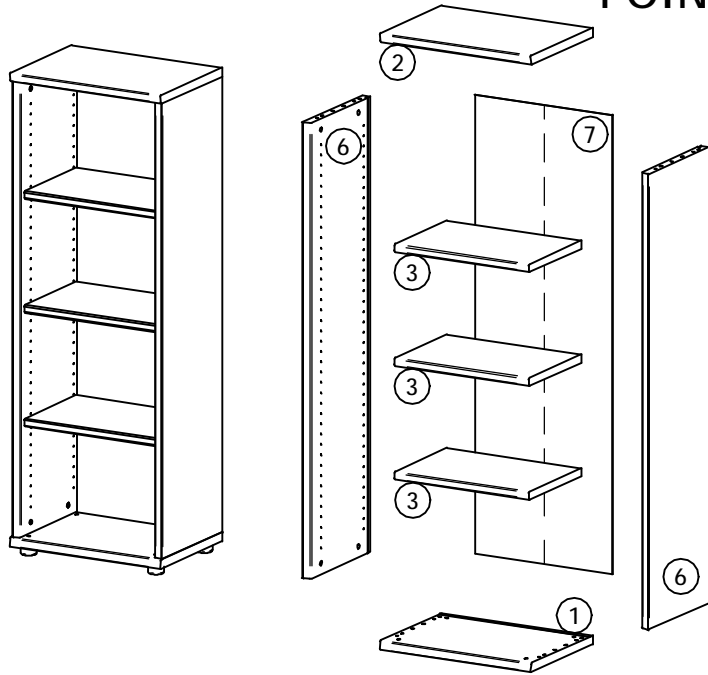

D	x10	EA	$\varnothing 10 \times 45$ x16	G	$\varnothing 5$ x12	I	x4
JD	$\varnothing 4 \times 25$ x10	L	$\varnothing 15$ x8	M	$\varnothing 8$ x8	Z	$\varnothing 5/2 \times 28$ x3
		KD	$\varnothing 15$ x8				

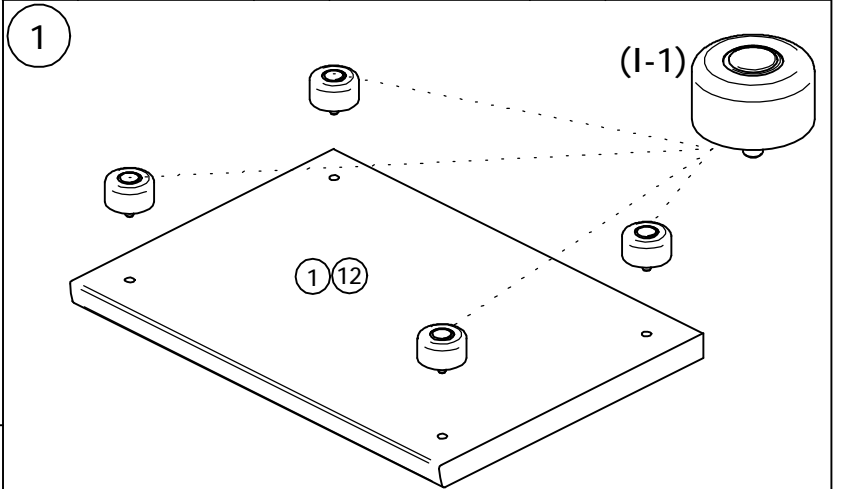
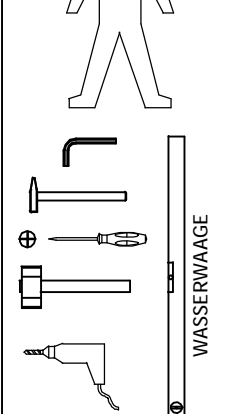

### POINT 82

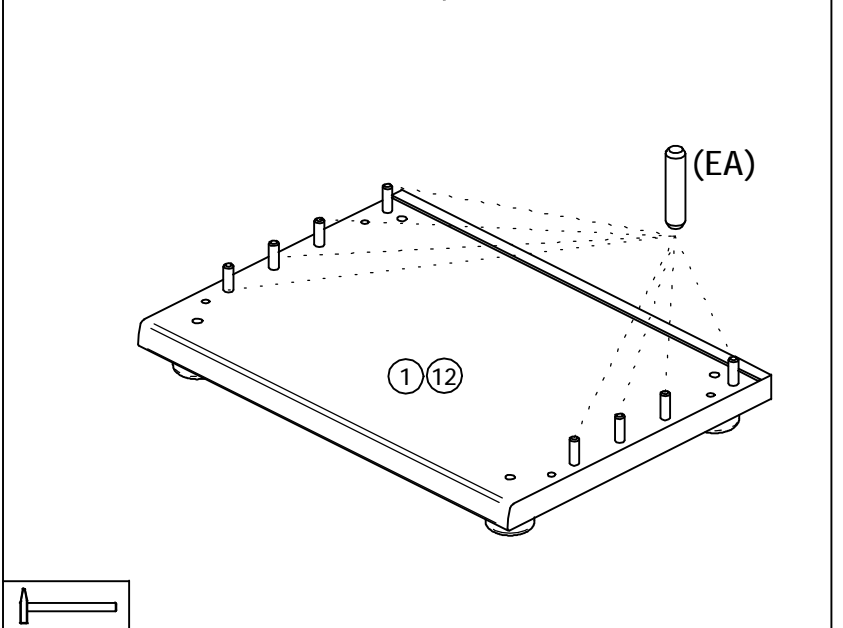
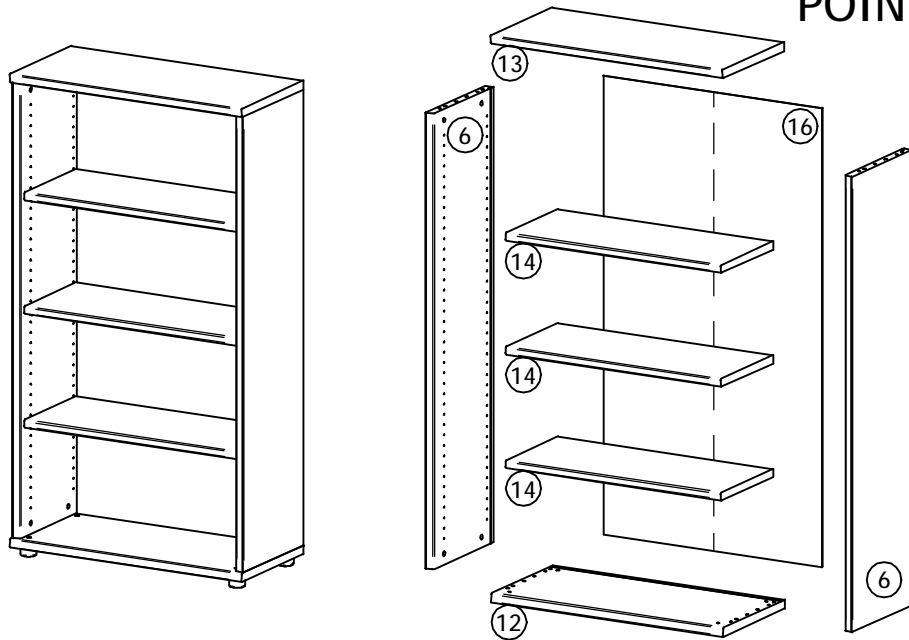

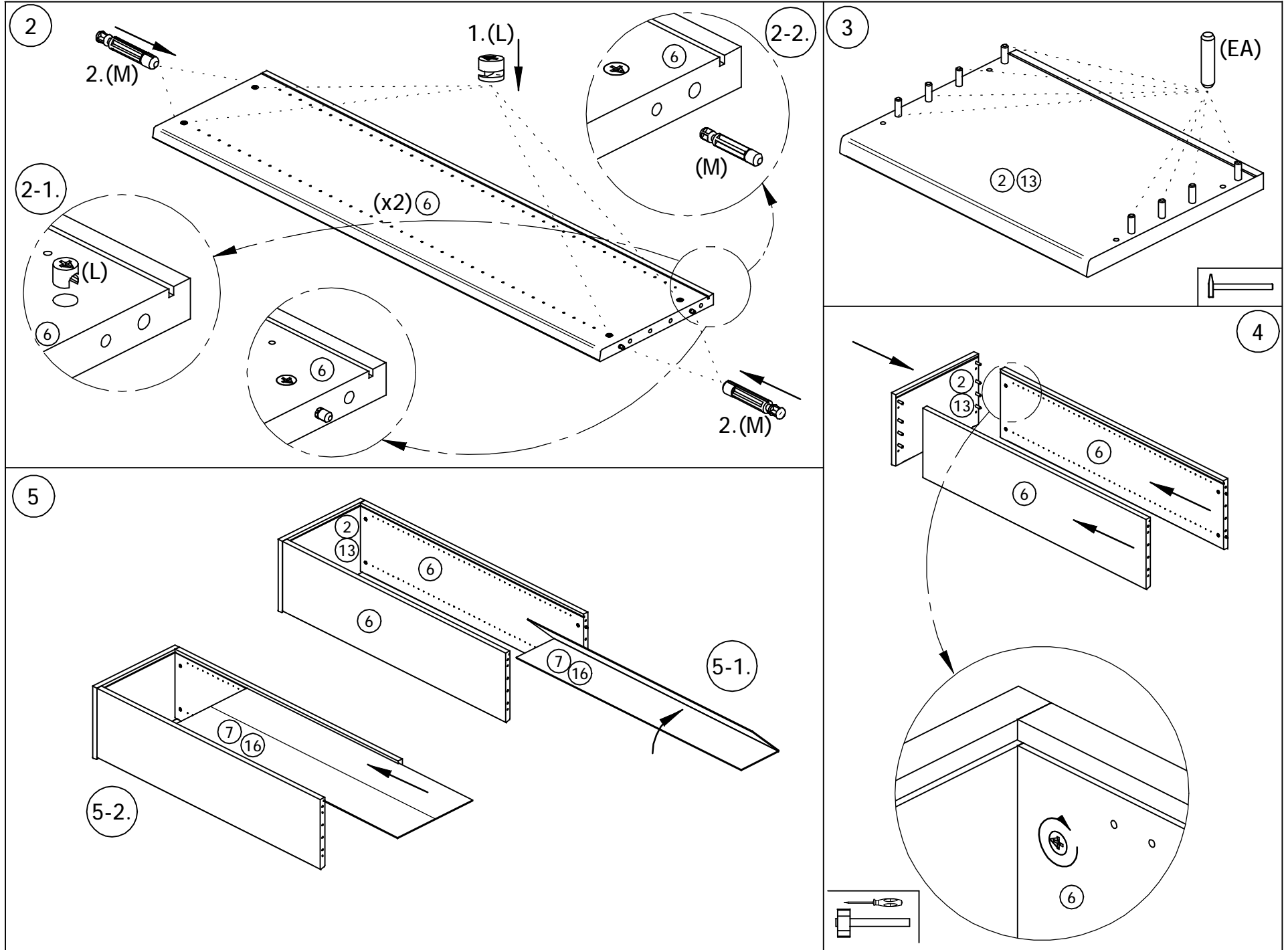

6

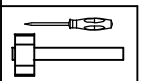
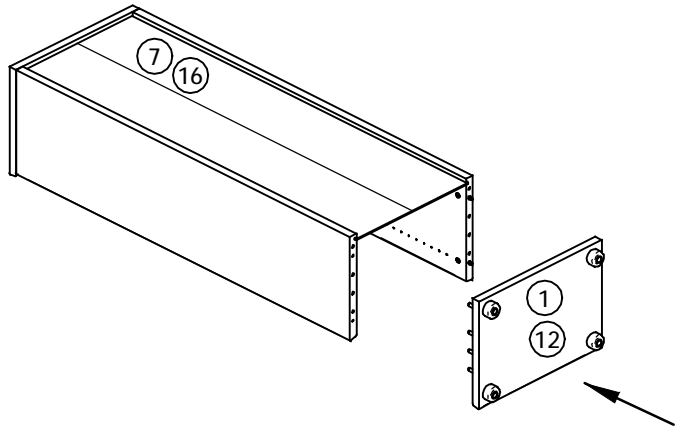

7

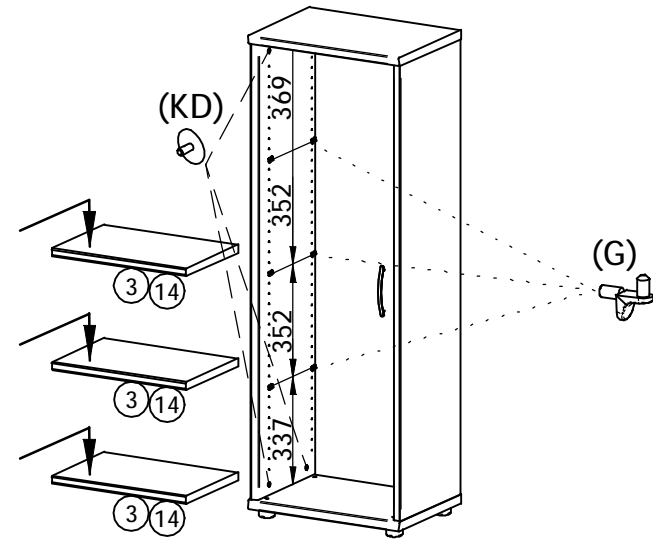

8

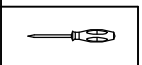
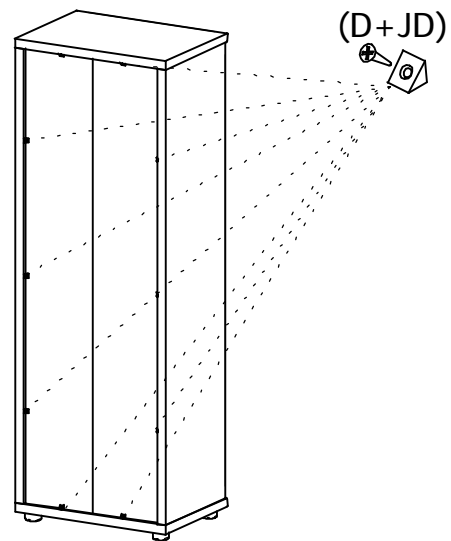

9

RECTIFICATION

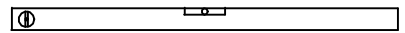
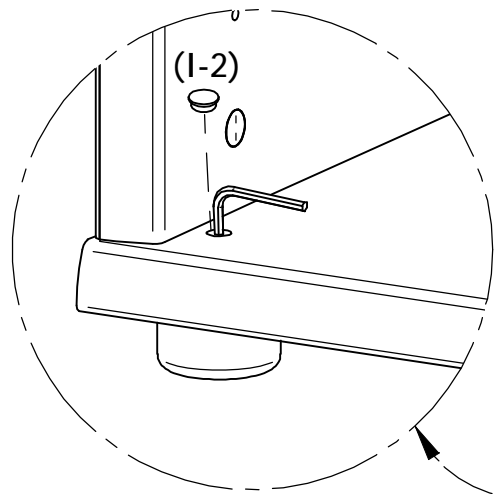

WASSERWAAGE

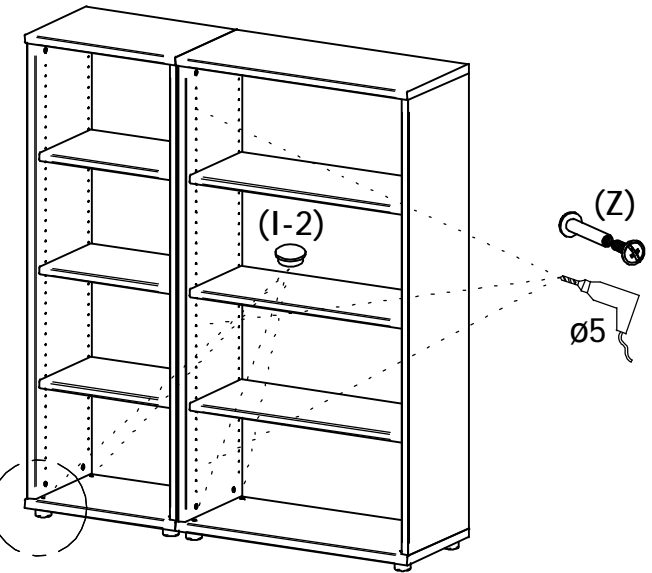

POINT T80  
 POINT T801  
 POINT T81

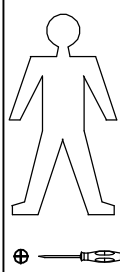

AA		x2	B		x4	C		x4
KE		x4	JA		ø3.5x15 x8	AC		M4x25 x4

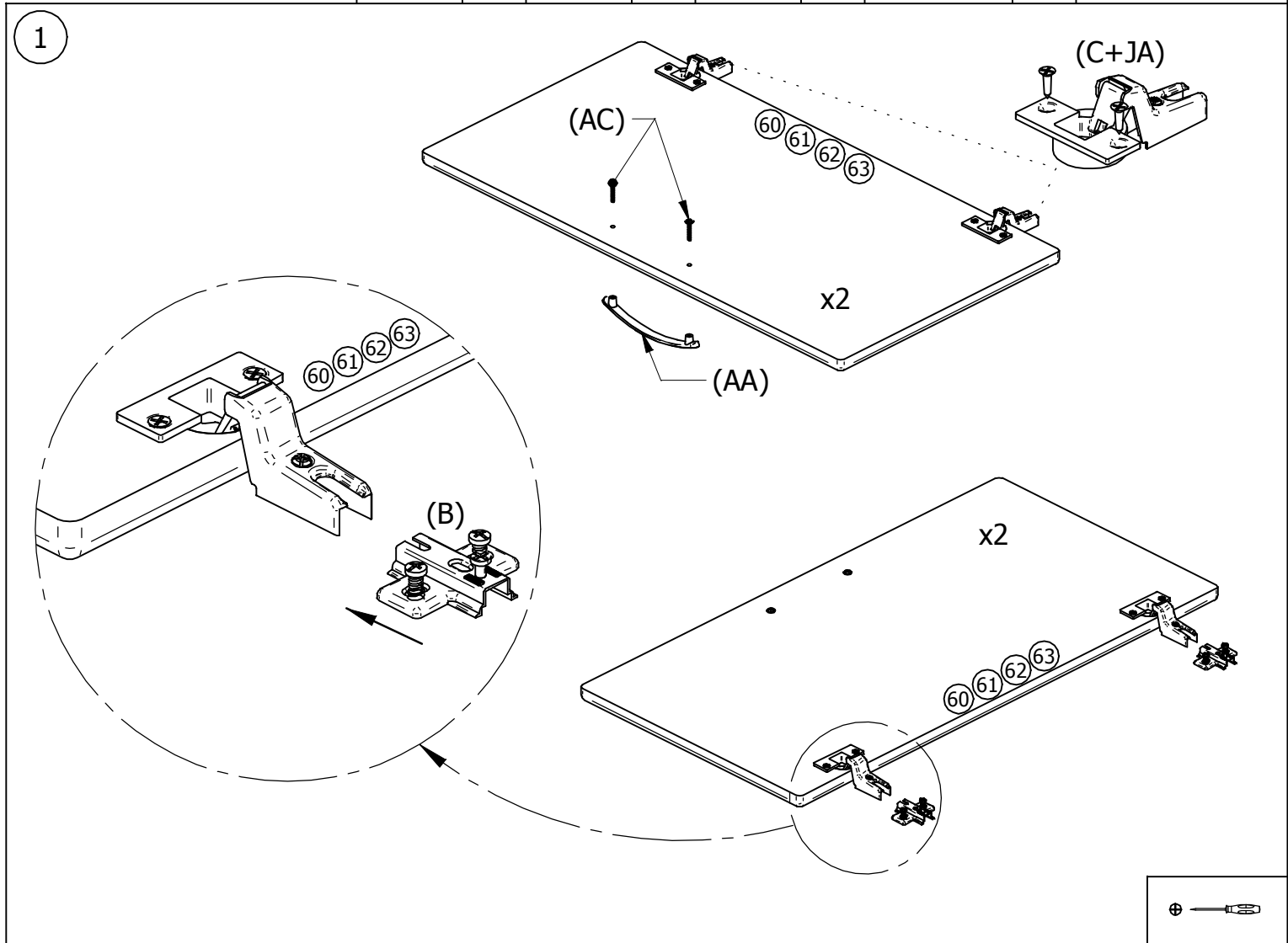
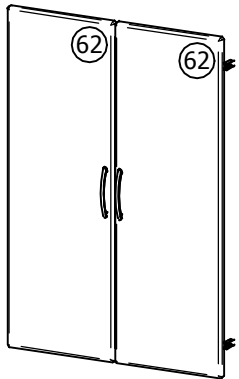
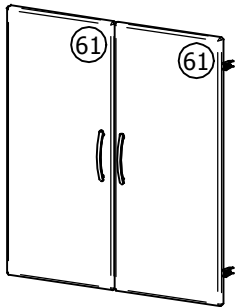
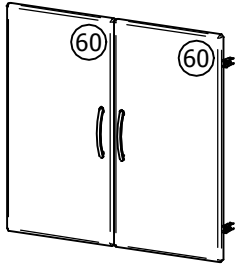

2

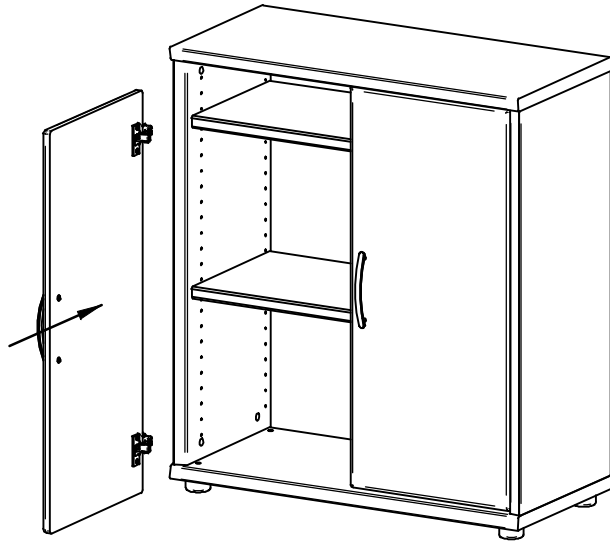

3

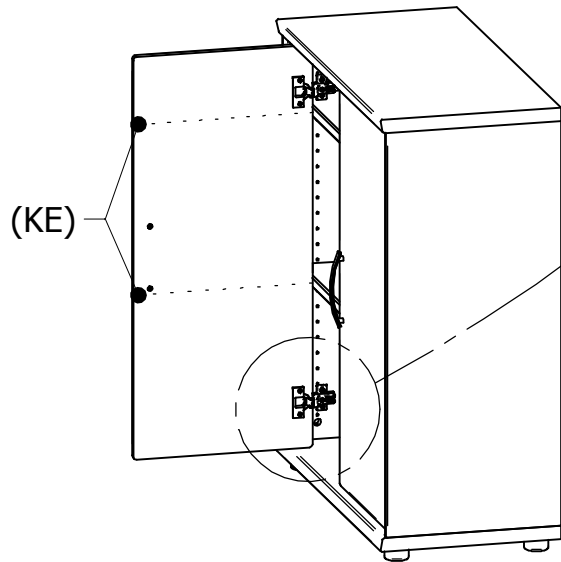
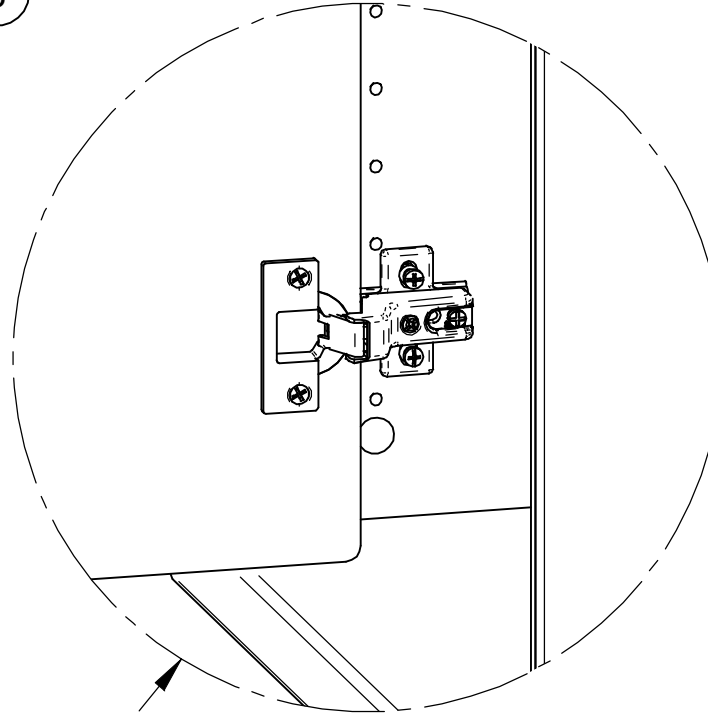
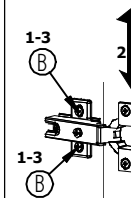
**NASTAVENIE DVERI / EINSTELLUNG VON TUREN**

- 1: SKRUTKU B POVOLIT  
DIE SCHRAUBEN B LOSEN
- 2: DVERE VYSKOVO NASTAVIT  
TUR IN DER HOHE JUSTIEREN
- 3: SKRUTKU B DOTIAHNUT  
DIE SCHRAUBEN B ANZIEHEN

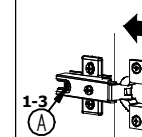

- 1: SKRUTKU A POVOLIT  
DIE SCHRAUBEN A LOSEN
- 2: DVERE HLBKOVO NASTAVIT  
TUR IN DER TIEFE JUSTIEREN
- 3: SKRUTKU A DOTIAHNUT  
SCHRAUBEN A ANZIEHEN

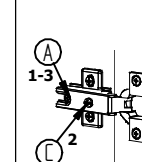

- 1: SKRUTKU A POVOLIT  
DIE SCHRAUBEN A LOSEN
- 2: DVERE STRANOVO SKRUTKOU C  
NASTAVIT  
TUR SEITLIGS MIT SCHRAUBE C  
JUSTIEREN
- 3: SKRUTKU A DOTIAHNUT  
SCHRAUBE A ANZIEHEN

