

MONTAGEANLEITUNG / MONTÁŽNY NÁVOD // SERVISKARTE / SERVISNÁ KARTA

POINT TYPE-80/TYP-80

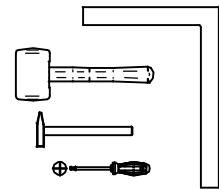
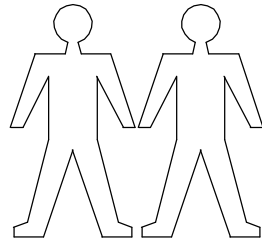
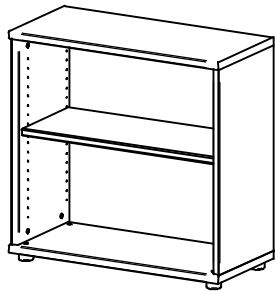

1	$\varnothing 10 \times 45$ x16	2	$\varnothing 8$ x8	3	$\varnothing 15$ x8	4	$\varnothing 15$ x8
5	x6	6	$\varnothing 3,5 \times 25$ x6	9	x4 a b	10	$\varnothing 5/2 \times 28$ x2
7	$\varnothing 5$ x4	8	x1				

BEACHTEN SIE BITTE, DASS BEI NICHT FACHGEMÄSSER MONTAGE, BZW. BEI ÜBERMÄSSIGER ODER UNGEEIGNETER BELASTUNG DES MÖBELS GEGENSTÄNDE ODER PERSONEN KANN DAS MÖBEL GEFÄHRLICH SEIN!

PROSÍM, MAJTE NA PAMÄTI, ŽE PRI NEODBORNEJ MONTÁŽI, PRÍPADNE NADMERNOM ALEBO NEVHODNOM ZAŤAŽOVANÍ NÁBYTKU PREDMETMI, ALEBO OSOBAMI MÔŽE BYŤ NÁBYTOK NEBEZPEČNÝ!

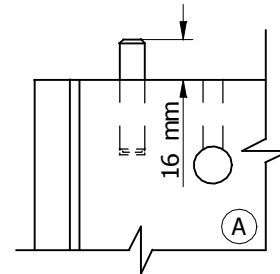
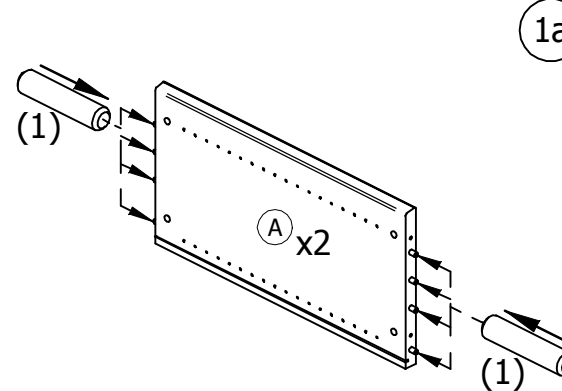
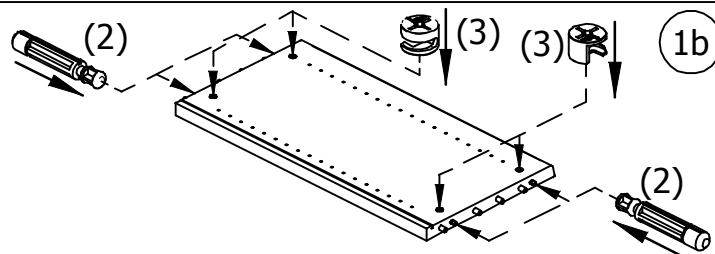
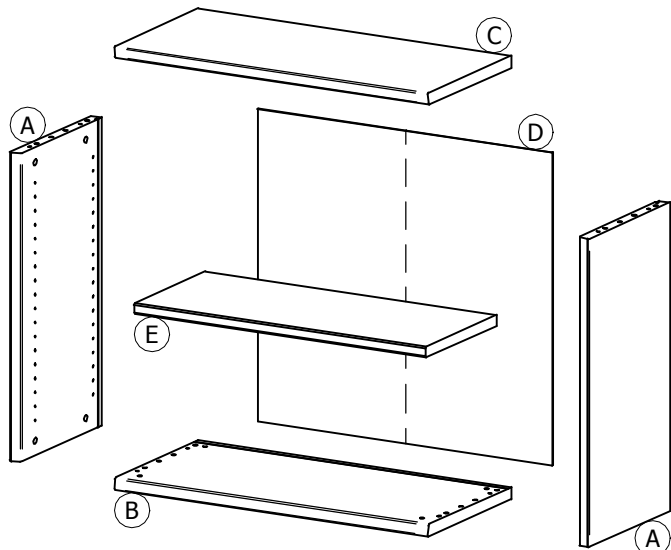

1a

zudrehen / zatiahnúť

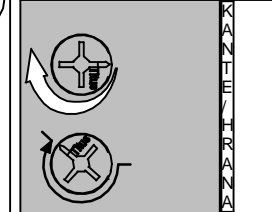

2

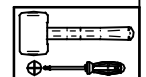
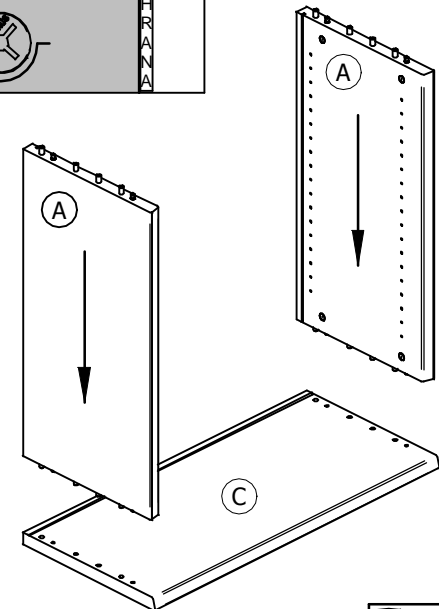

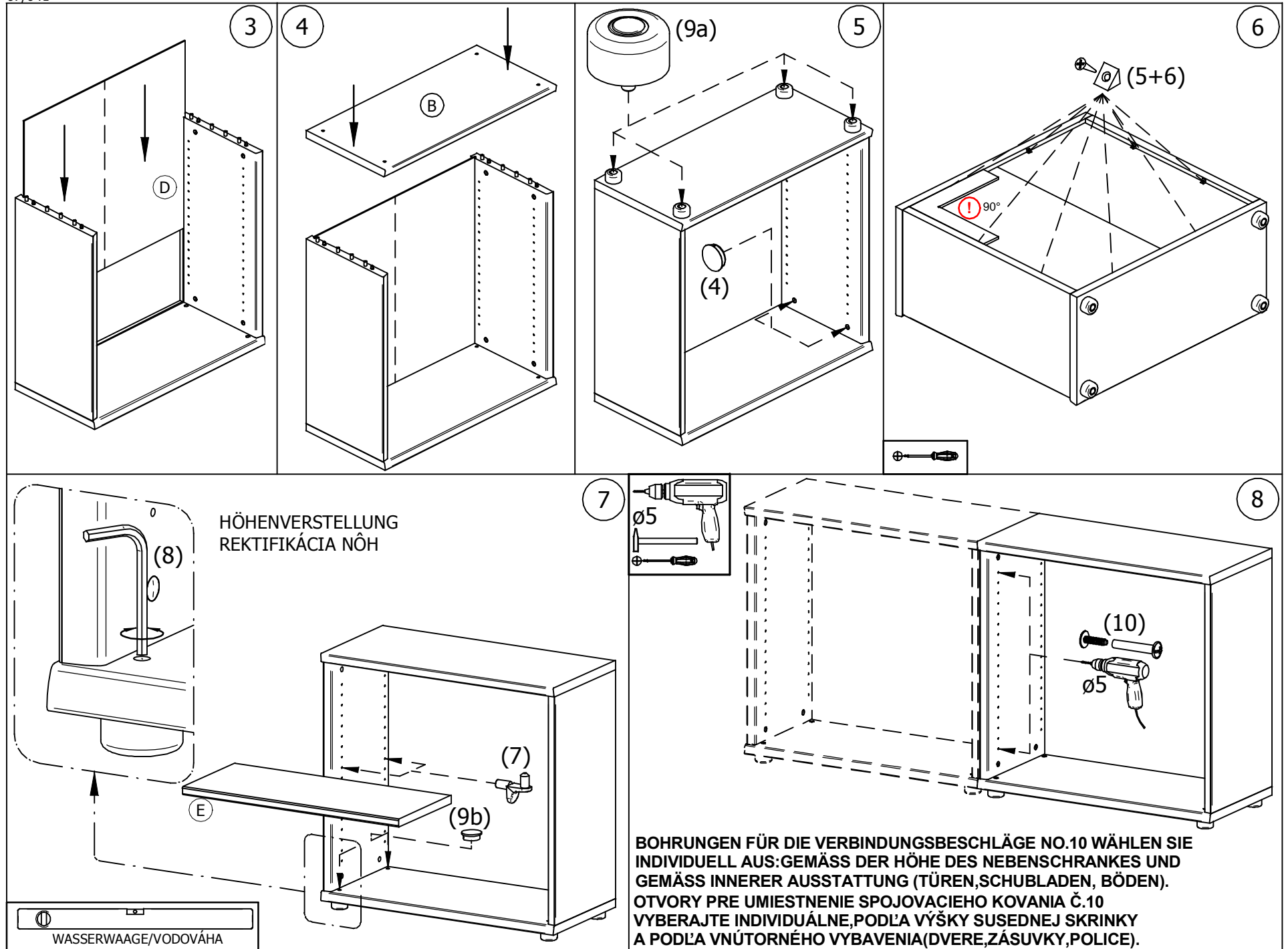

POINT T80
 POINT T801
 POINT T81

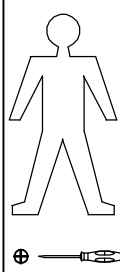

AA		x2	B		x4	C		x4
KE		x4	JA		ø3.5x15 x8	AC		M4x25 x4

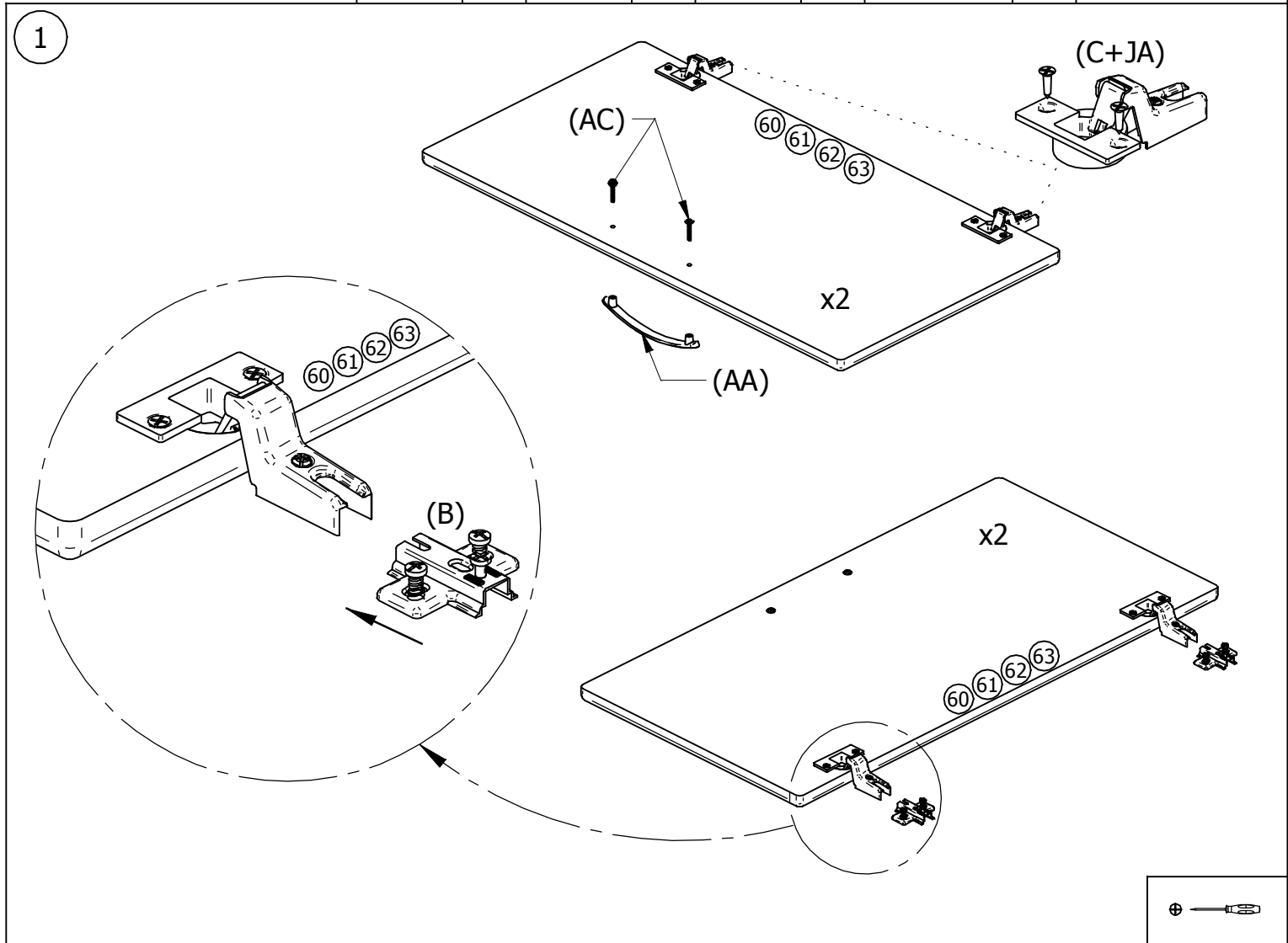
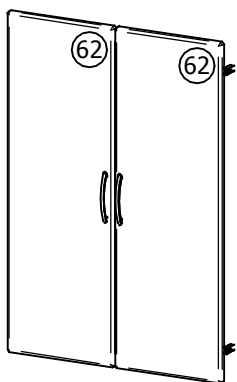
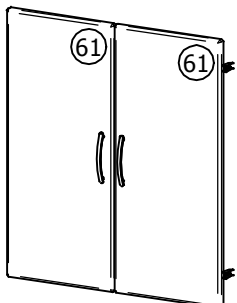
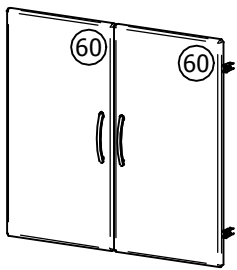

2

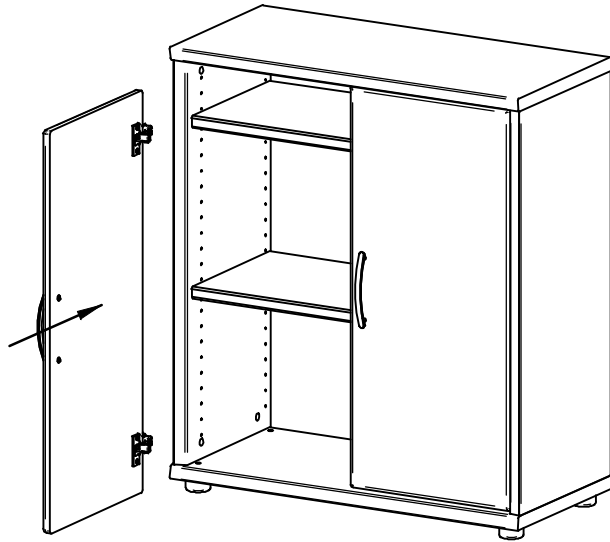

3

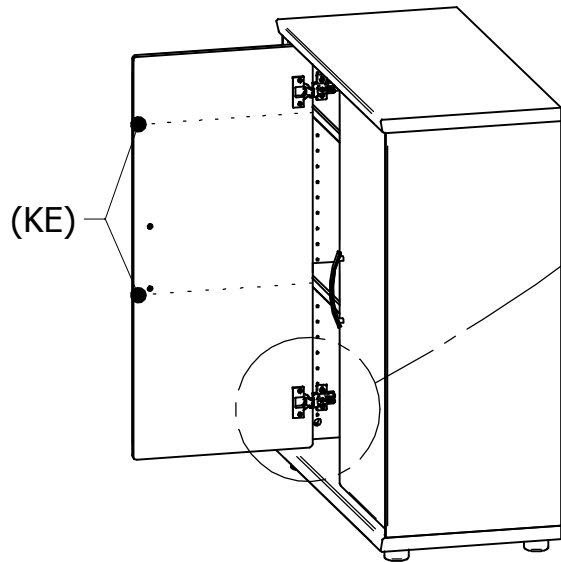
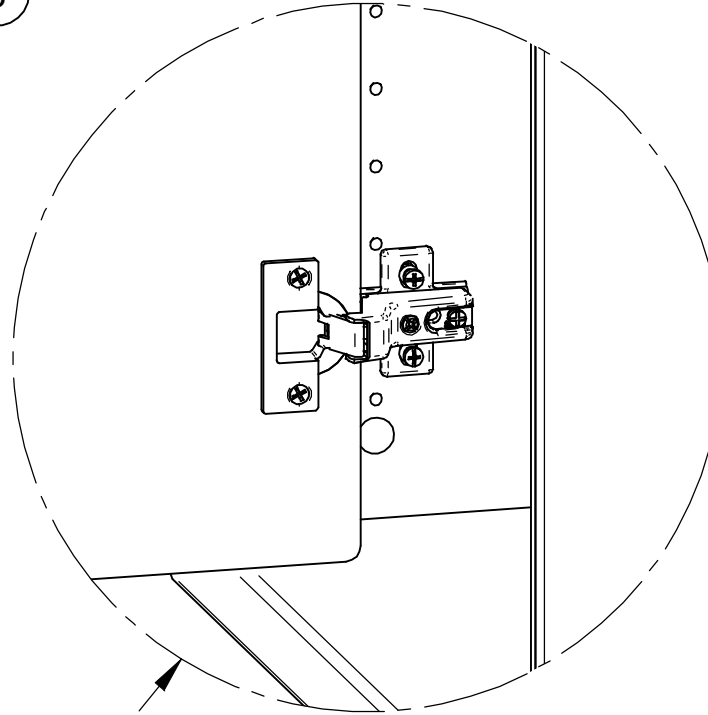
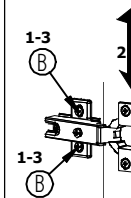
NASTAVENIE DVERI / EINSTELLUNG VON TUREN

- 1: SKRUTKU B POVOLIT
DIE SCHRAUBEN B LOSEN
- 2: DVERE VYSKOVO NASTAVIT
TUR IN DER HOHE JUSTIEREN
- 3: SKRUTKU B DOTIAHNUT
DIE SCHRAUBEN B ANZIEHEN

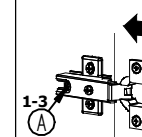

- 1: SKRUTKU A POVOLIT
DIE SCHRAUBEN A LOSEN
- 2: DVERE HLBKOVO NASTAVIT
TUR IN DER TIEFE JUSTIEREN
- 3: SKRUTKU A DOTIAHNUT
SCHRAUBEN A ANZIEHEN

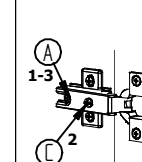

- 1: SKRUTKU A POVOLIT
DIE SCHRAUBEN A LOSEN
- 2: DVERE STRANOVO SKRUTKOU C
NASTAVIT
TUR SEITLIGS MIT SCHRAUBE C
JUSTIEREN
- 3: SKRUTKU A DOTIAHNUT
SCHRAUBE A ANZIEHEN