

12/003-1

### POINT 53

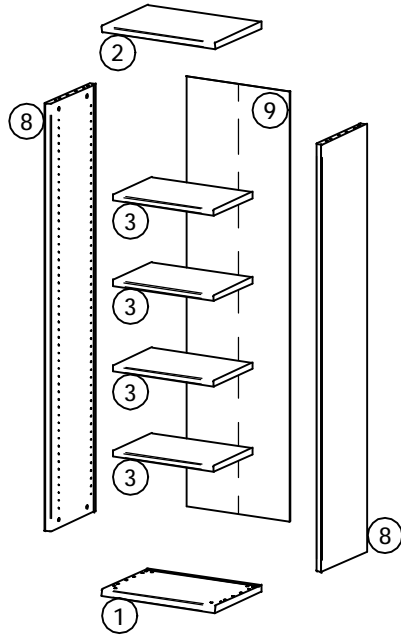

D	x12	EA	$\varnothing 10 \times 45$ x16	G	$\varnothing 5$ x16	I	x4
JD	$\varnothing 4 \times 25$ x12	L	$\varnothing 15$ x8	M	$\varnothing 8$ x8		
		KD	$\varnothing 15$ x8			Z	$\varnothing 5/2 \times 28$ x4

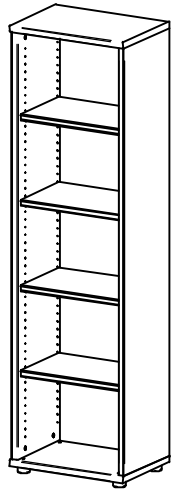
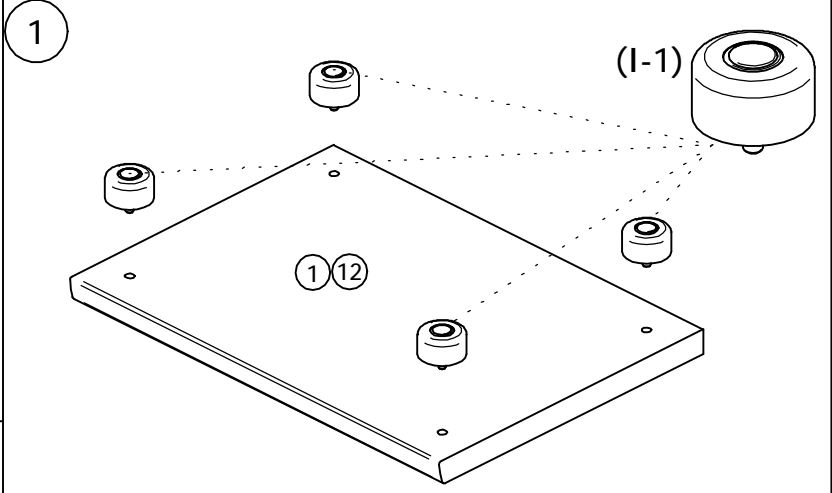
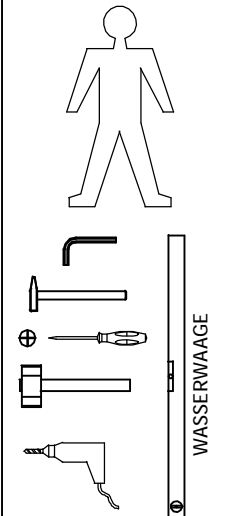

### POINT 83

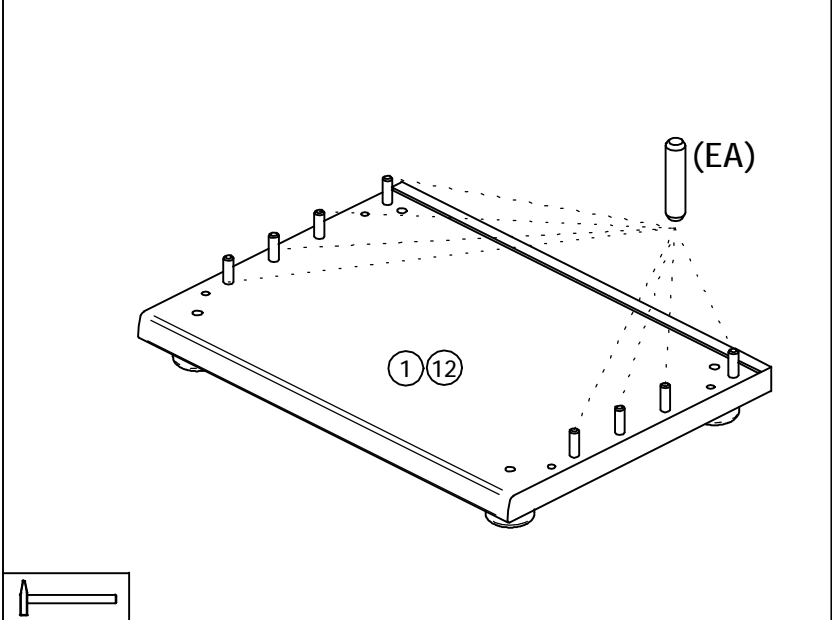
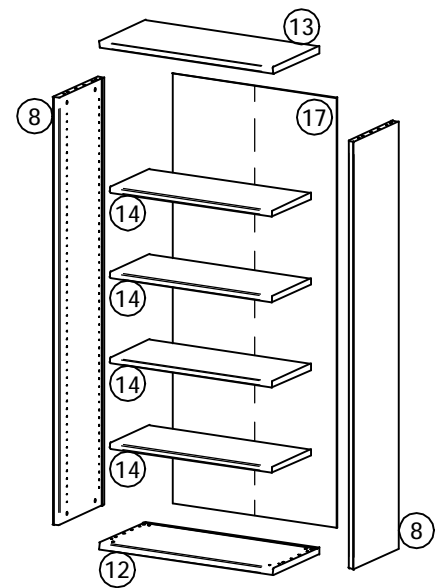
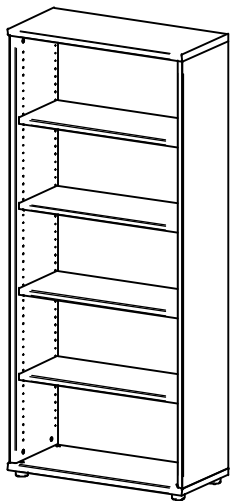

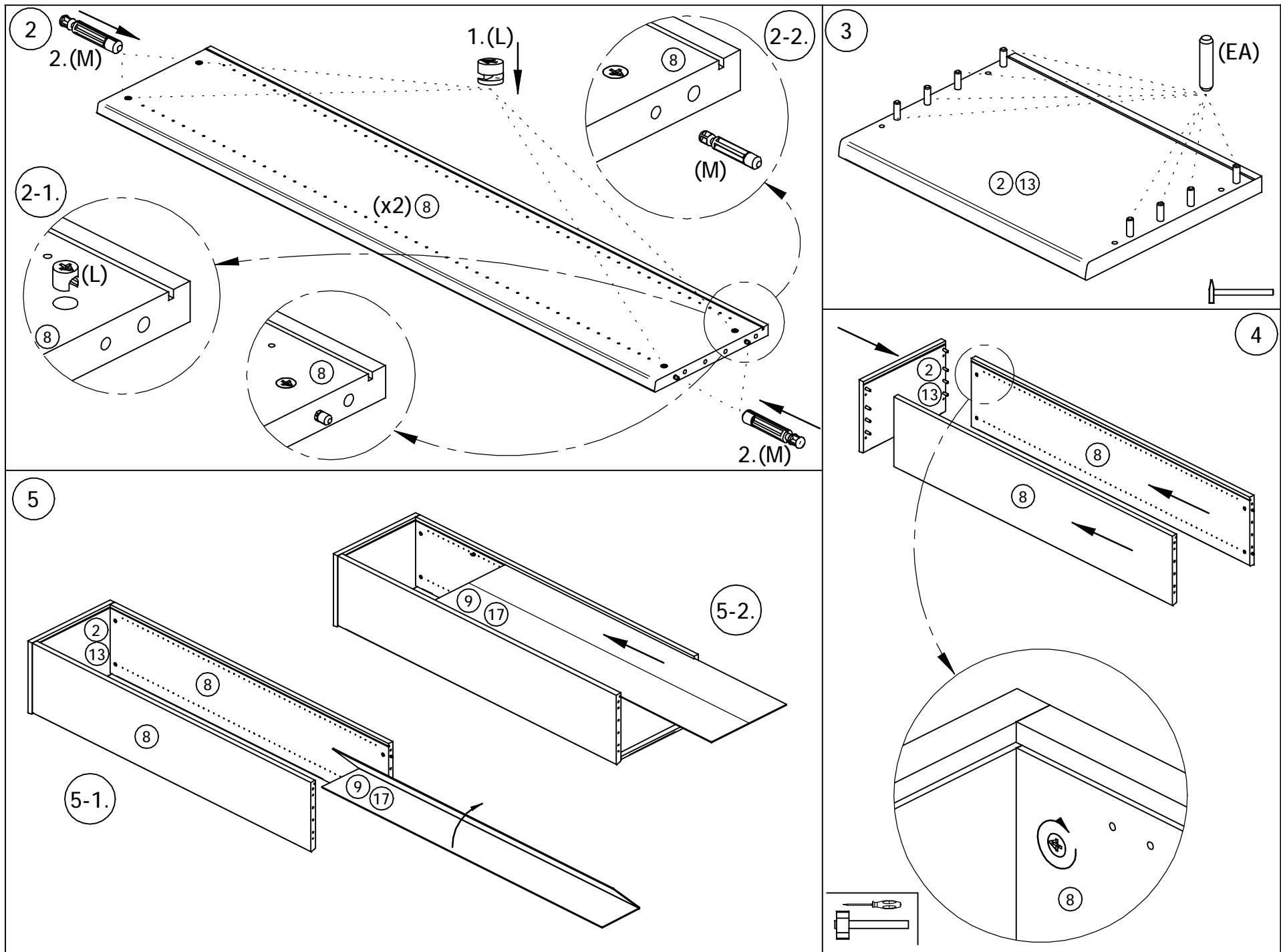

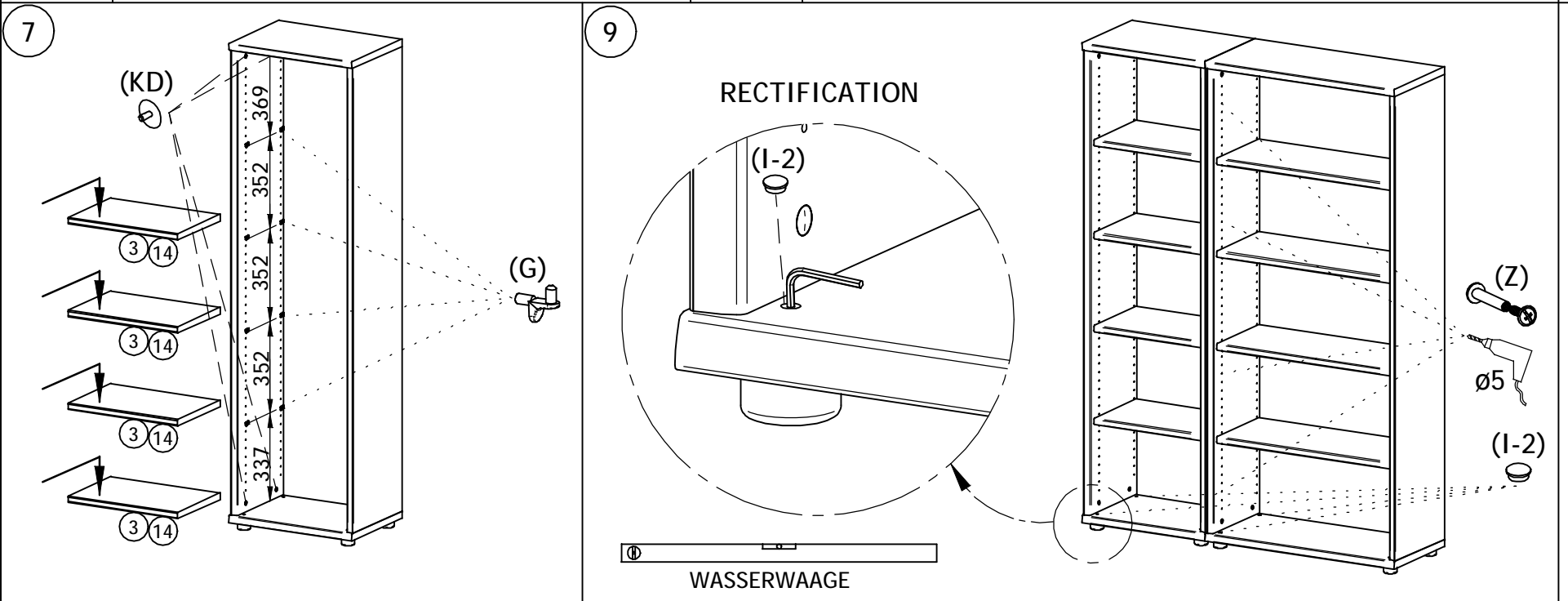
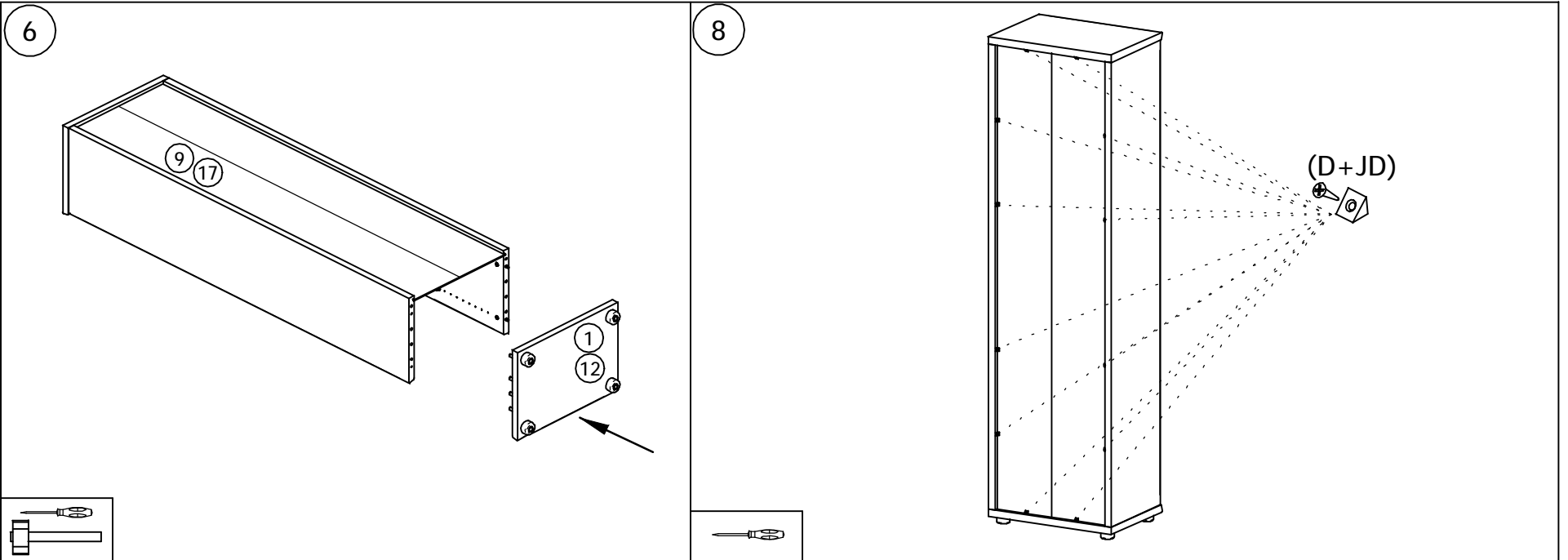

POINT T50  
 POINT T51  
 POINT T501

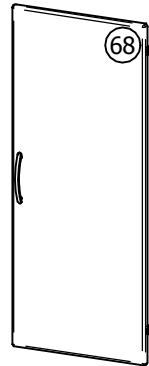
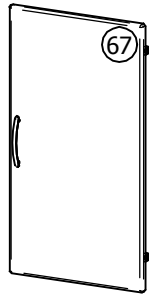
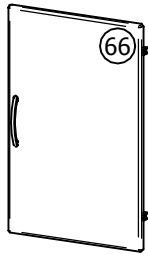

AA 	x1	x2	x2
	KE	x2	$\varnothing 3.5 \times 15$ x4

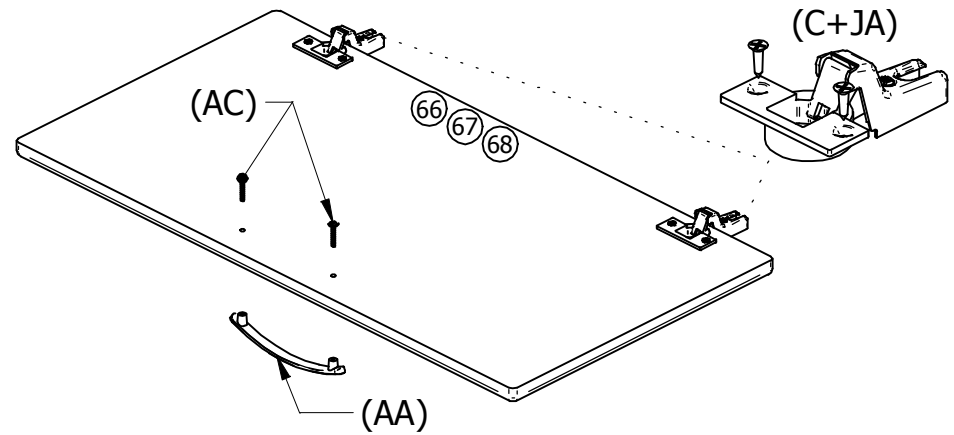

1

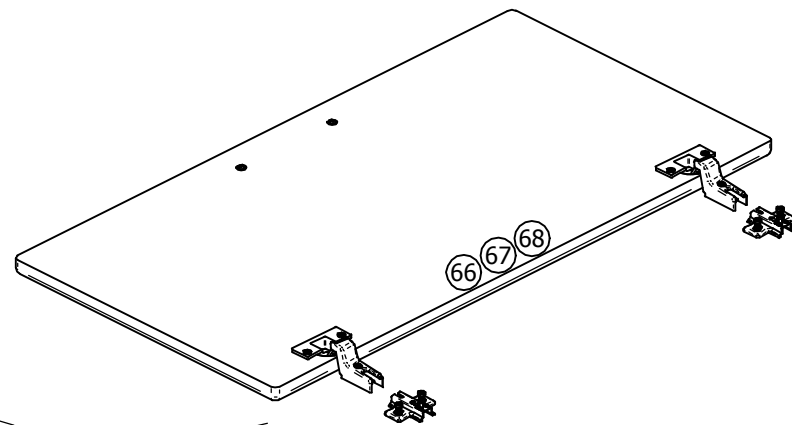
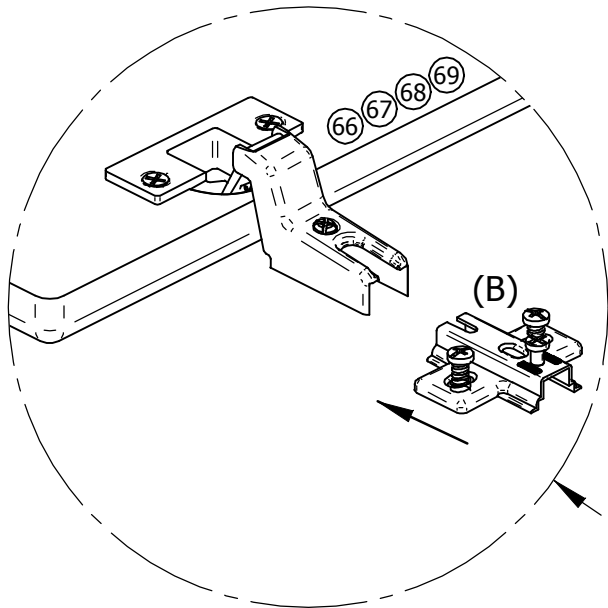

2

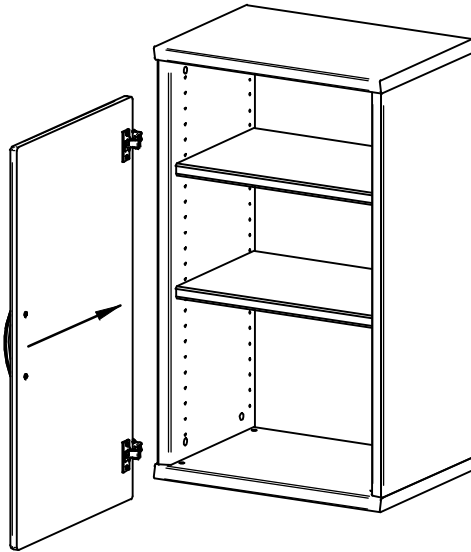

3

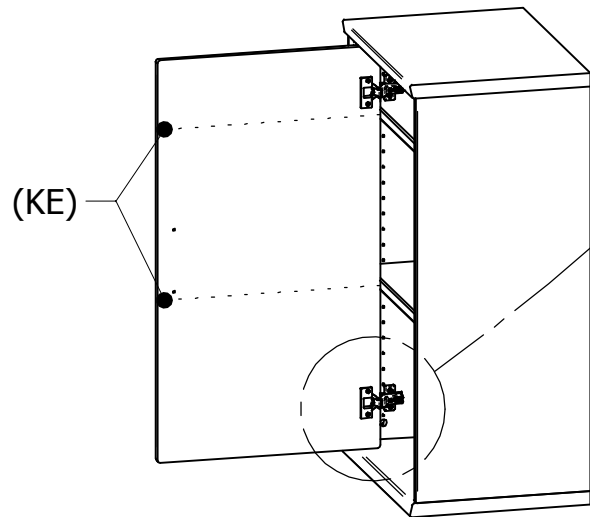
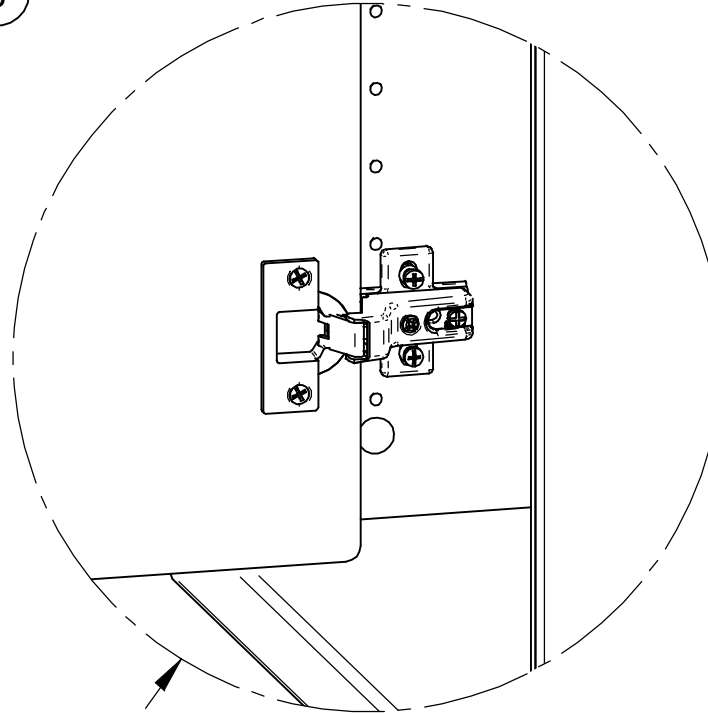
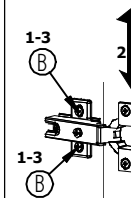
**NASTAVENIE DVERI / EINSTELLUNG VON TUREN**

- 1: SKRUTKU B POVOLIT  
DIE SCHRAUBEN B LOSEN
- 2: DVERE VYSKOVO NASTAVIT  
TUR IN DER HOHE JUSTIEREN
- 3: SKRUTKU B DOTIAHNUT  
DIE SCHRAUBEN B ANZIEHEN

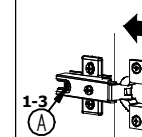

- 1: SKRUTKU A POVOLIT  
DIE SCHRAUBEN A LOSEN
- 2: DVERE HLBKOVO NASTAVIT  
TUR IN DER TIEFE JUSTIEREN
- 3: SKRUTKU A DOTIAHNUT  
SCHRAUBEN A ANZIEHEN

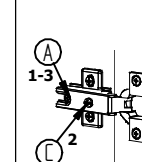

- 1: SKRUTKU A POVOLIT  
DIE SCHRAUBEN A LOSEN
- 2: DVERE STRANOVO SKRUTKOU C  
NASTAVIT  
TUR SEITLIGS MIT SCHRAUBE C  
JUSTIEREN
- 3: SKRUTKU A DOTIAHNUT  
SCHRAUBE A ANZIEHEN

