

12/004-1

POINT 54

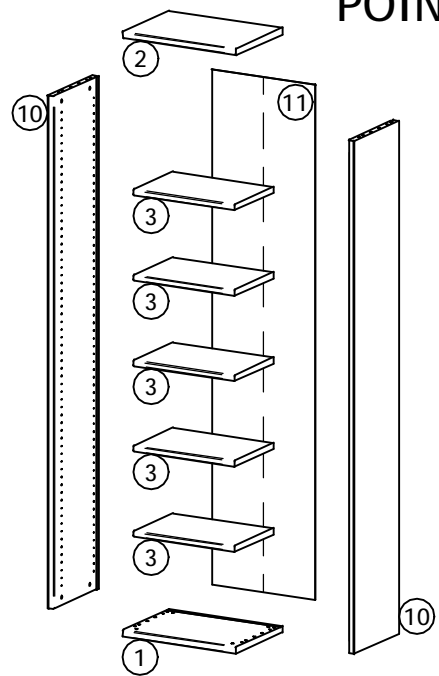

D	x14	EA	$\varnothing 10 \times 45$ x16	G	$\varnothing 5$ x20	I	x4
JD	$\varnothing 4 \times 25$ x14	L	$\varnothing 15$ x8	M	$\varnothing 8$ x8	Z	$\varnothing 5/2 \times 28$ x4
		KD	$\varnothing 15$ x8				

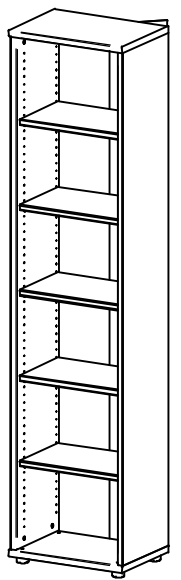
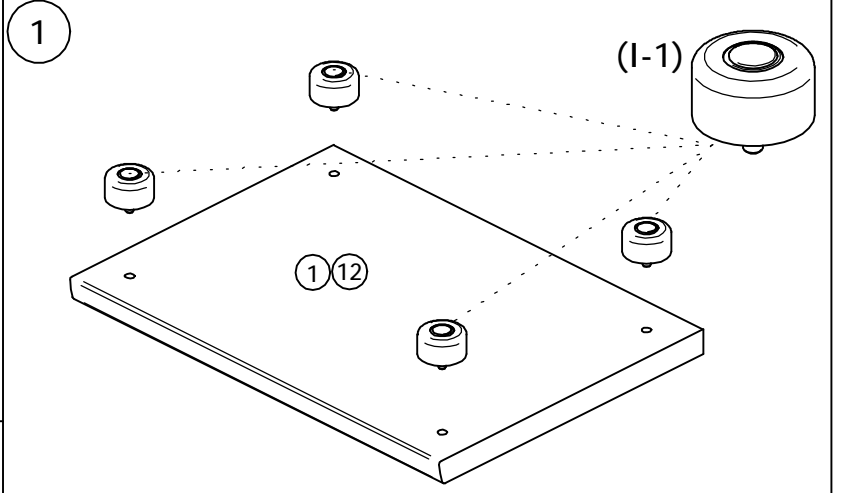
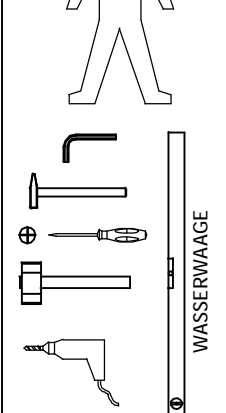

POINT 84

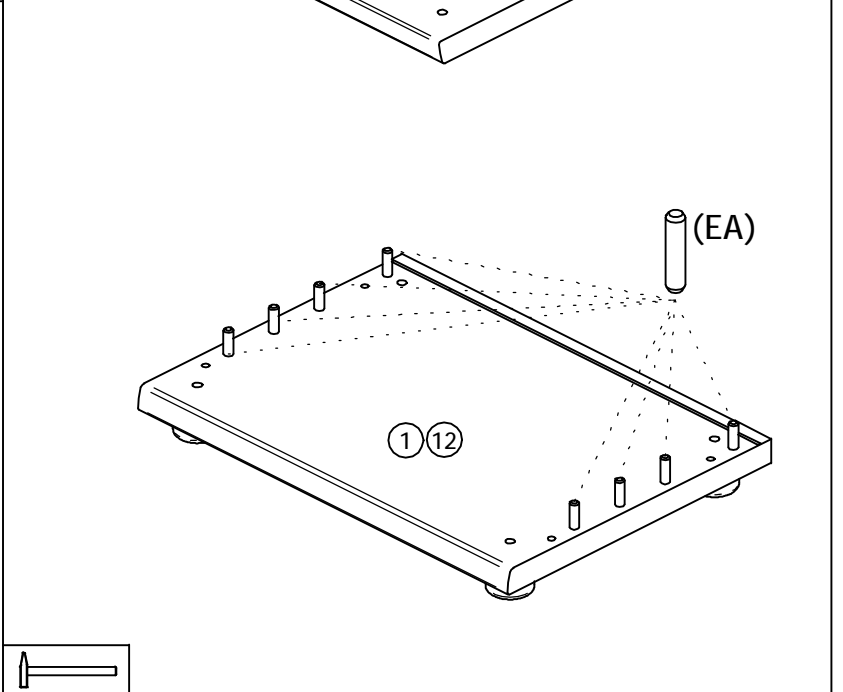
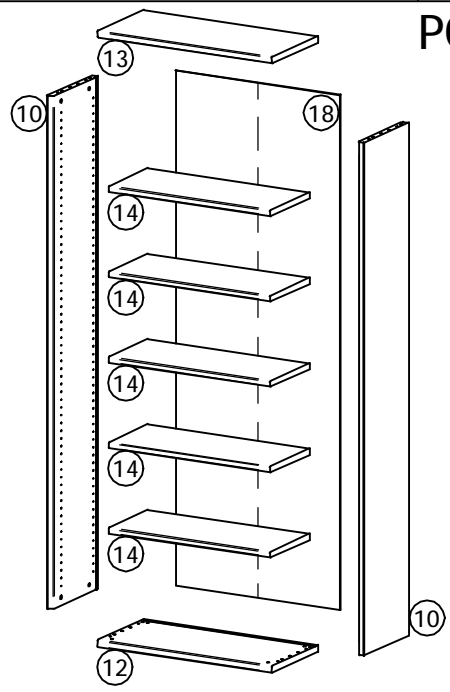
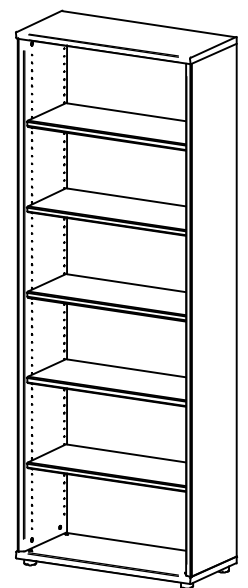

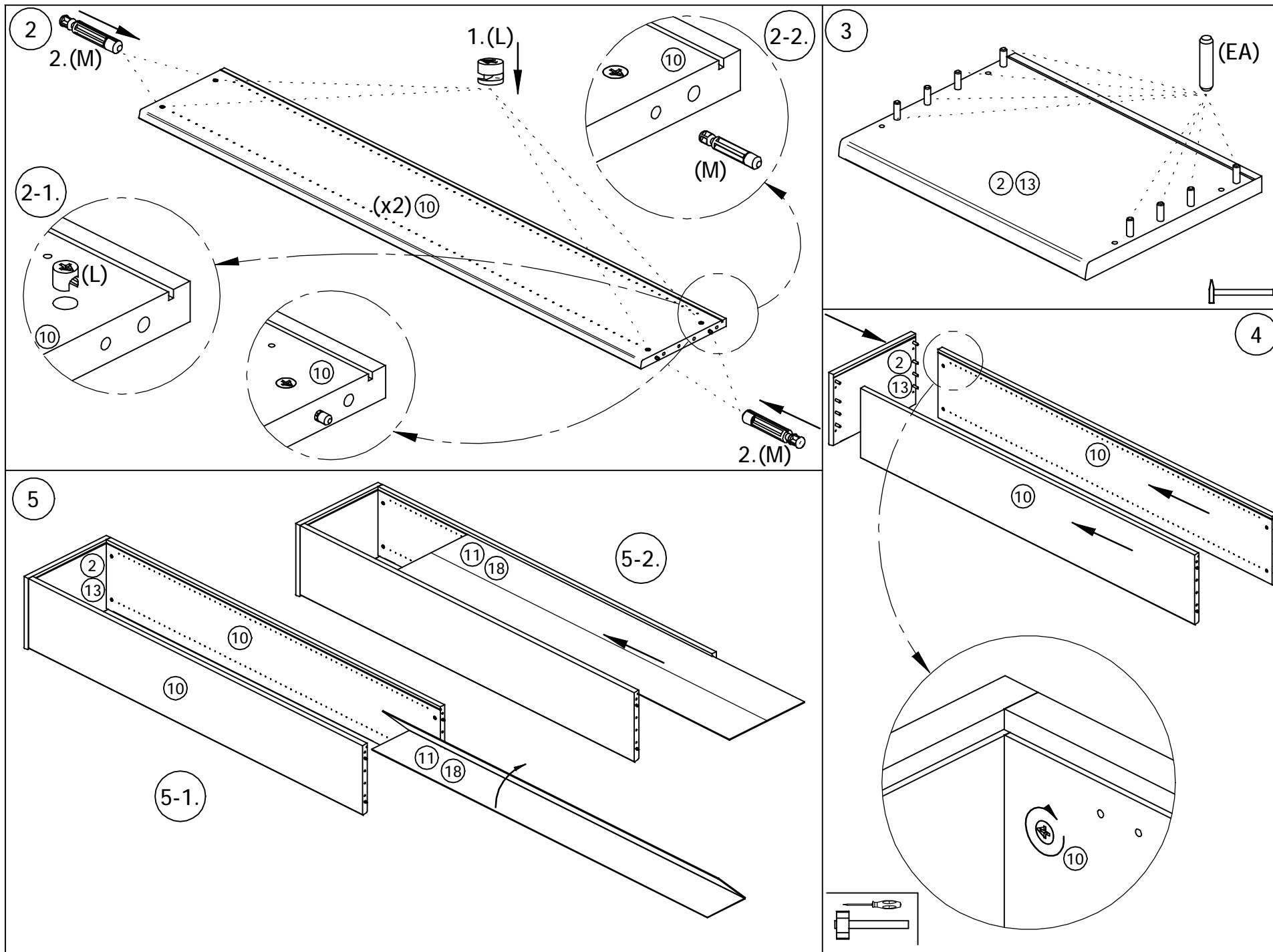

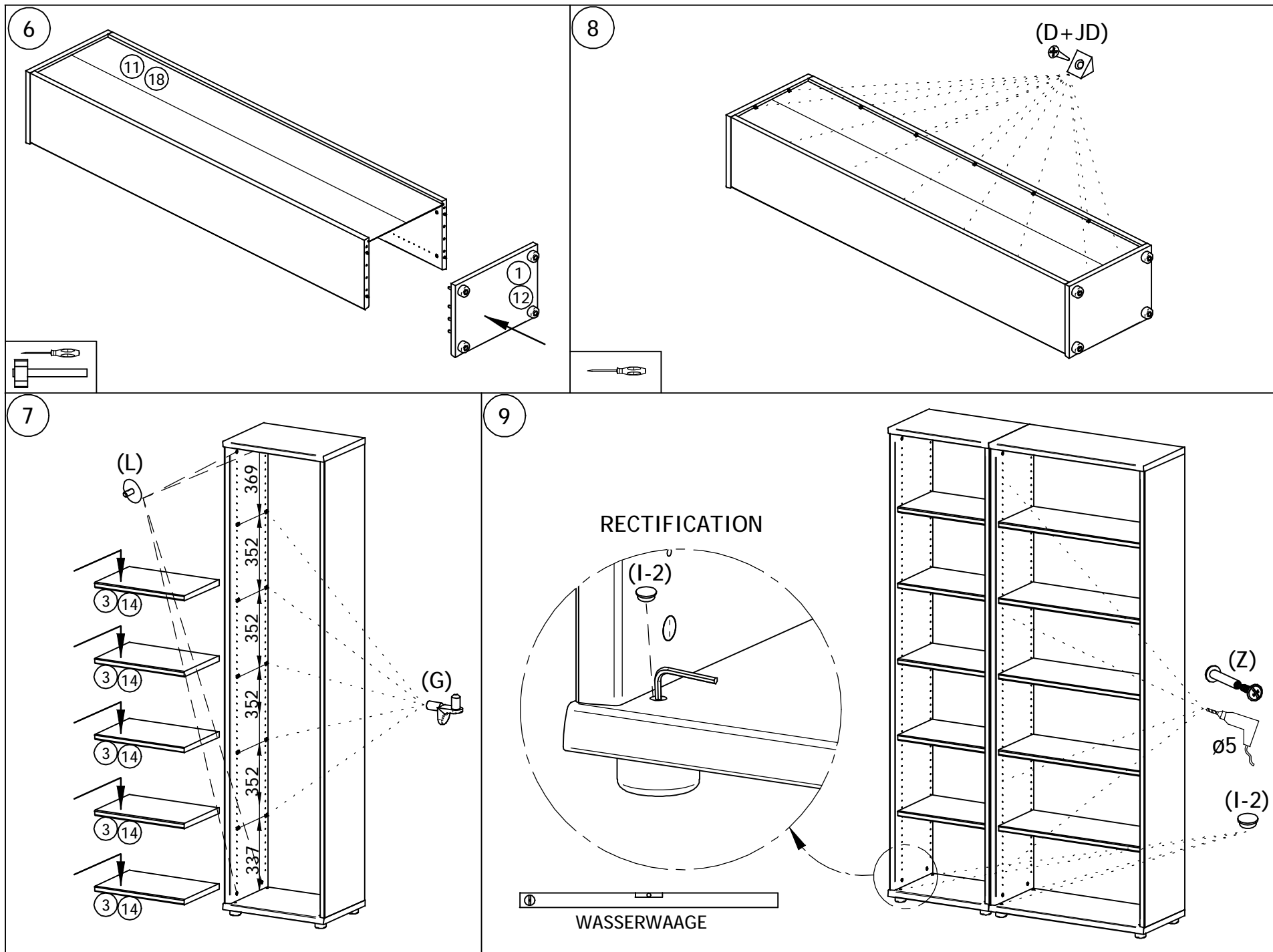

POINT T50
 POINT T51
 POINT T501

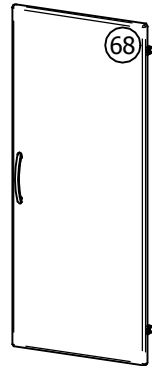
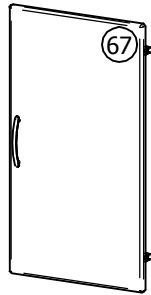
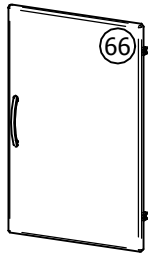

 AA 	 x1	B x2	C x2
	KE x2	JA x4	AC x4

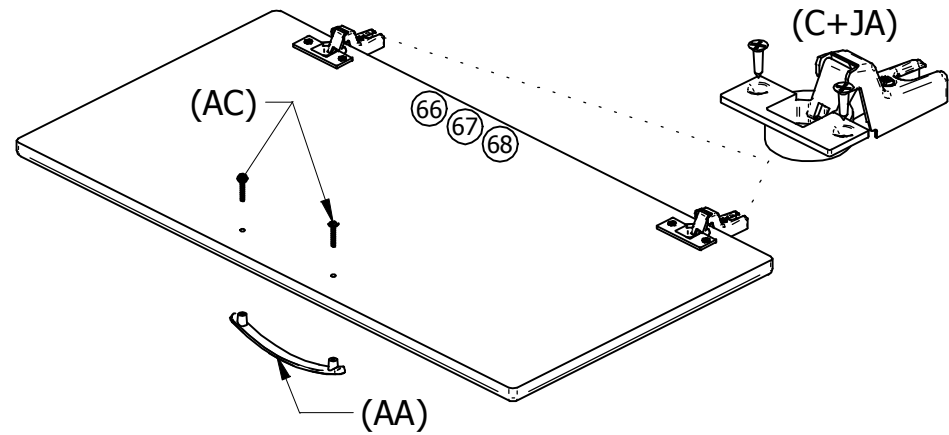

1

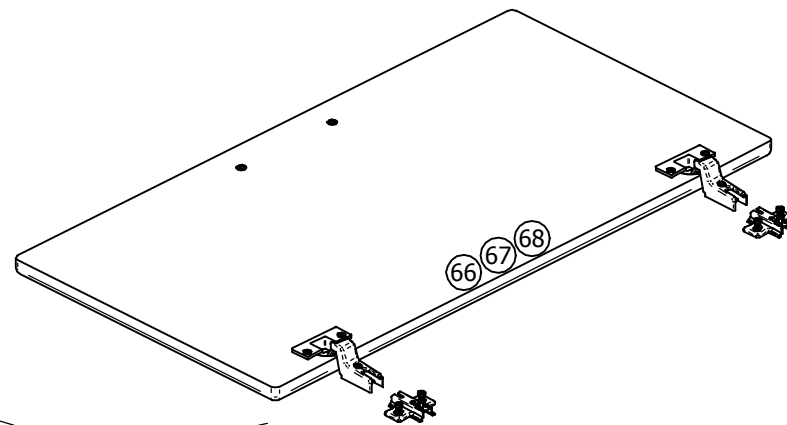
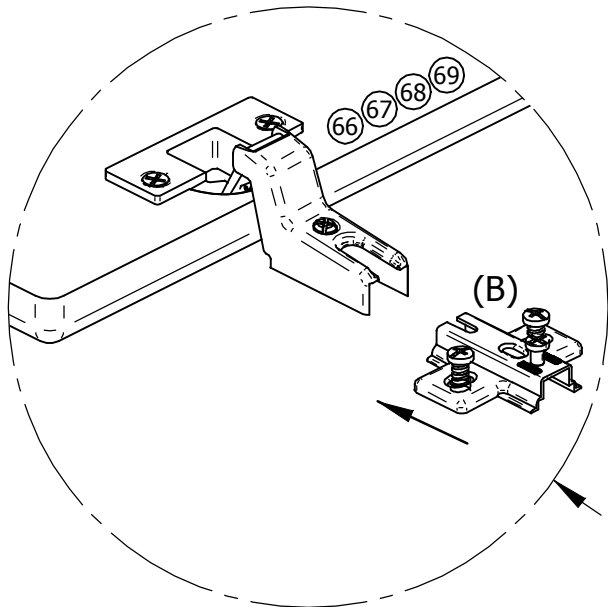

2

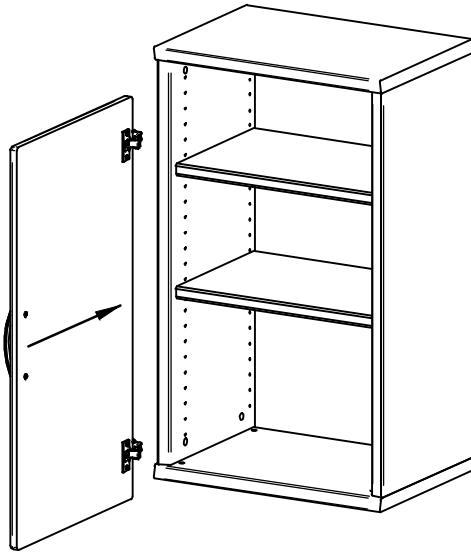

3

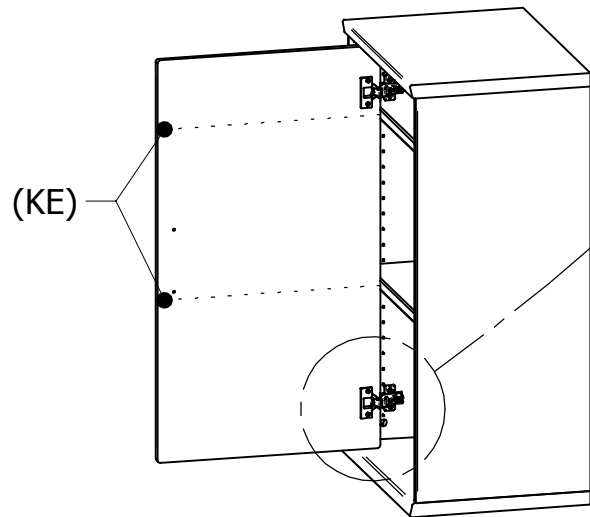
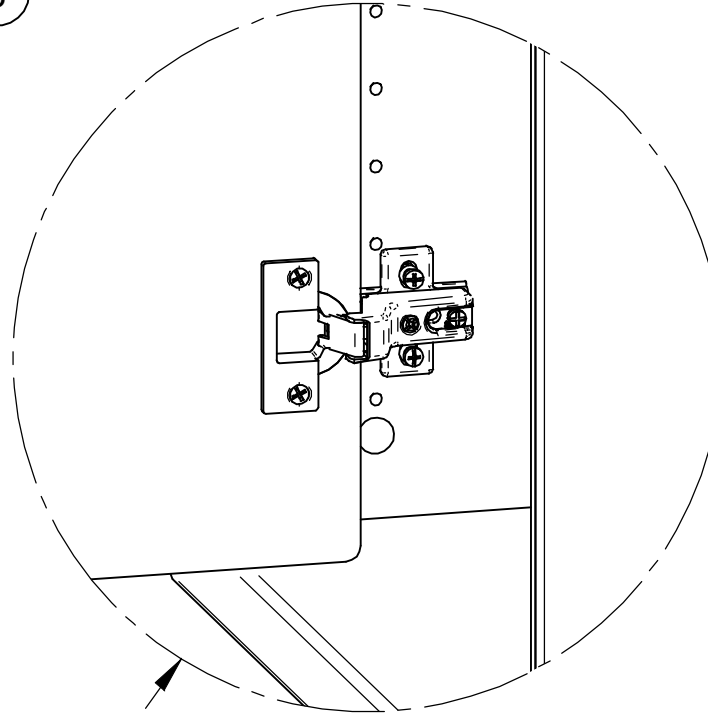
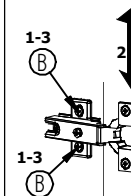
NASTAVENIE DVERI / EINSTELLUNG VON TUREN

- 1: SKRUTKU B POVOLIT
DIE SCHRAUBEN B LOSEN
- 2: DVERE VYSKOVO NASTAVIT
TUR IN DER HOHE JUSTIEREN
- 3: SKRUTKU B DOTIAHNUT
DIE SCHRAUBEN B ANZIEHEN

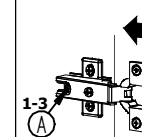

- 1: SKRUTKU A POVOLIT
DIE SCHRAUBEN A LOSEN
- 2: DVERE HLBKOVO NASTAVIT
TUR IN DER TIEFE JUSTIEREN
- 3: SKRUTKU A DOTIAHNUT
SCHRAUBEN A ANZIEHEN

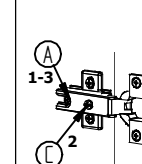

- 1: SKRUTKU A POVOLIT
DIE SCHRAUBEN A LOSEN
- 2: DVERE STRANOVO SKRUTKOU C
NASTAVIT
TUR SEITLIGS MIT SCHRAUBE C
JUSTIEREN
- 3: SKRUTKU A DOTIAHNUT
SCHRAUBE A ANZIEHEN

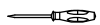

POINT S 5X

POINT S 8X

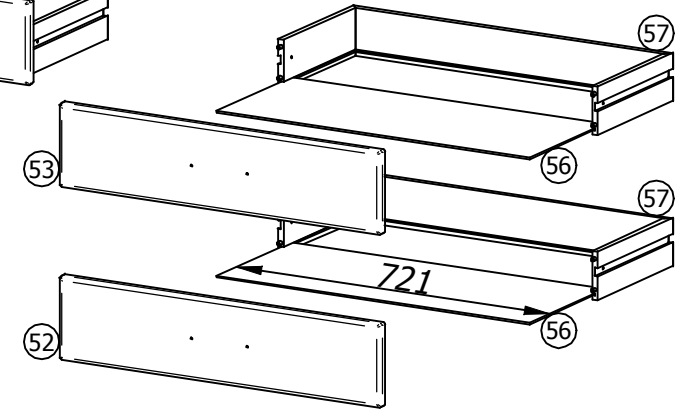
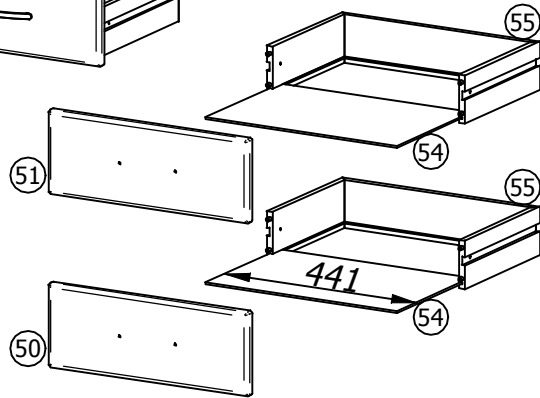
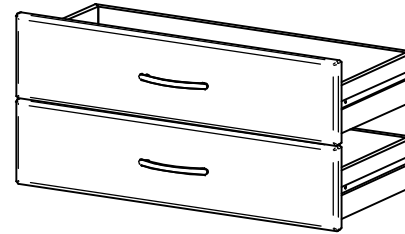
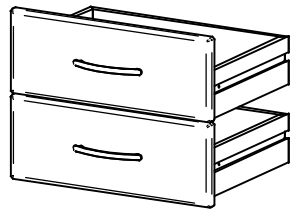

	OBERSCHUBKASTEN	AA O P	x2 N	x4 X	S 5X-x4 S 8X-6x
	UNTERSCHUBKASTEN				
	(51)(53) (50)(52)		ØM4x10 x4 KE	x4 AC M4x25 x4 F x1	(X+Y)

1

2

3

4

