

12/003-1

POINT 53

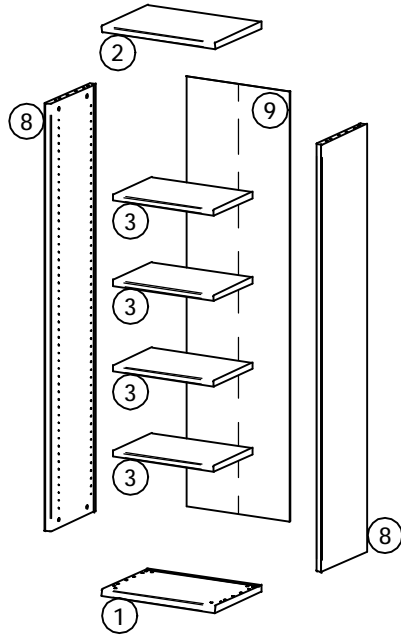

D	x12	EA	$\varnothing 10 \times 45$ x16	G	$\varnothing 5$ x16	I	x4
JD	$\varnothing 4 \times 25$ x12	L	$\varnothing 15$ x8	M	$\varnothing 8$ x8		
		KD	$\varnothing 15$ x8			Z	$\varnothing 5/2 \times 28$ x4

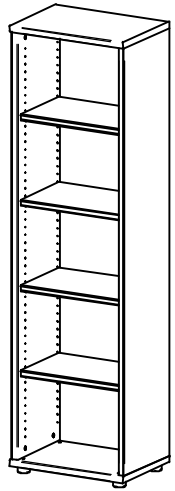
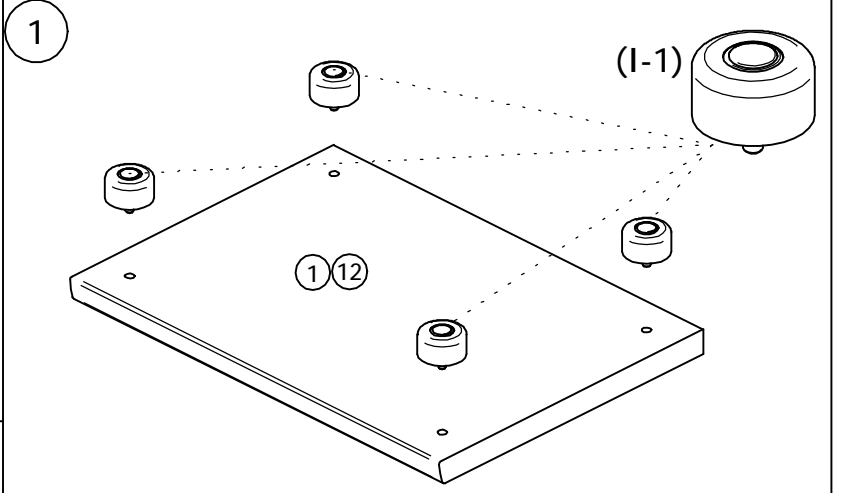
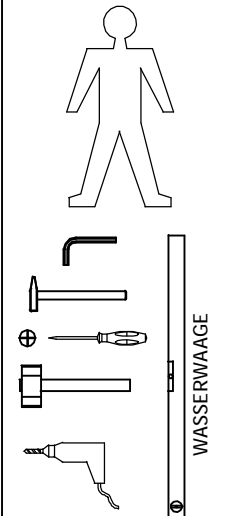



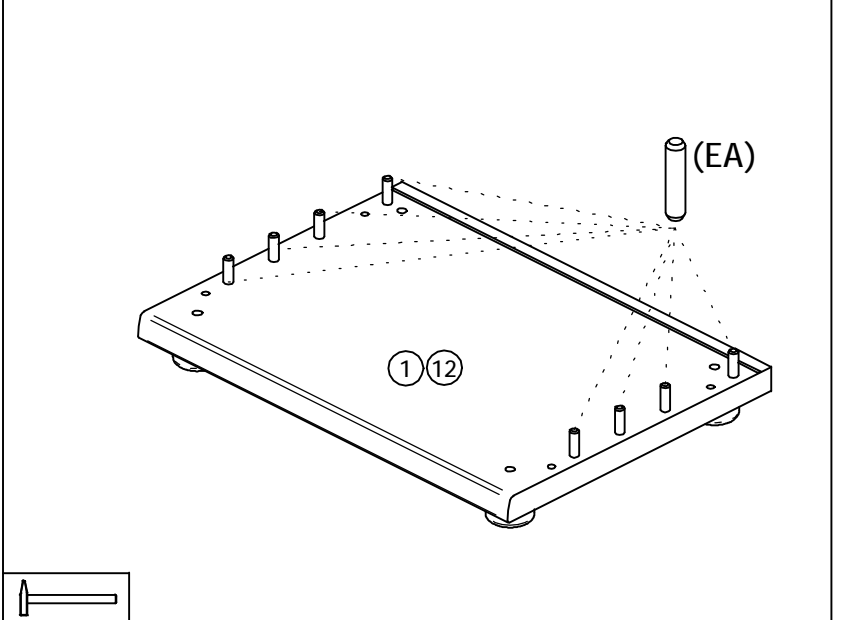
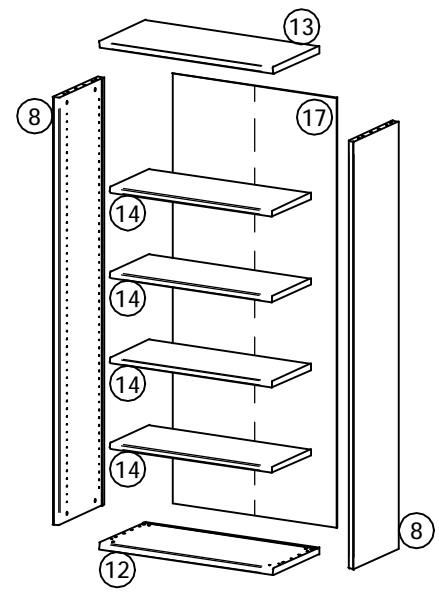
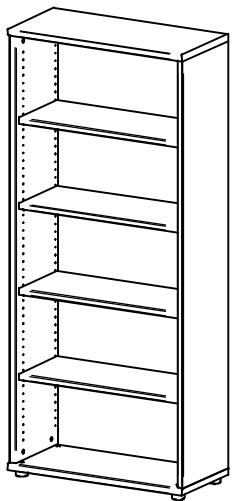

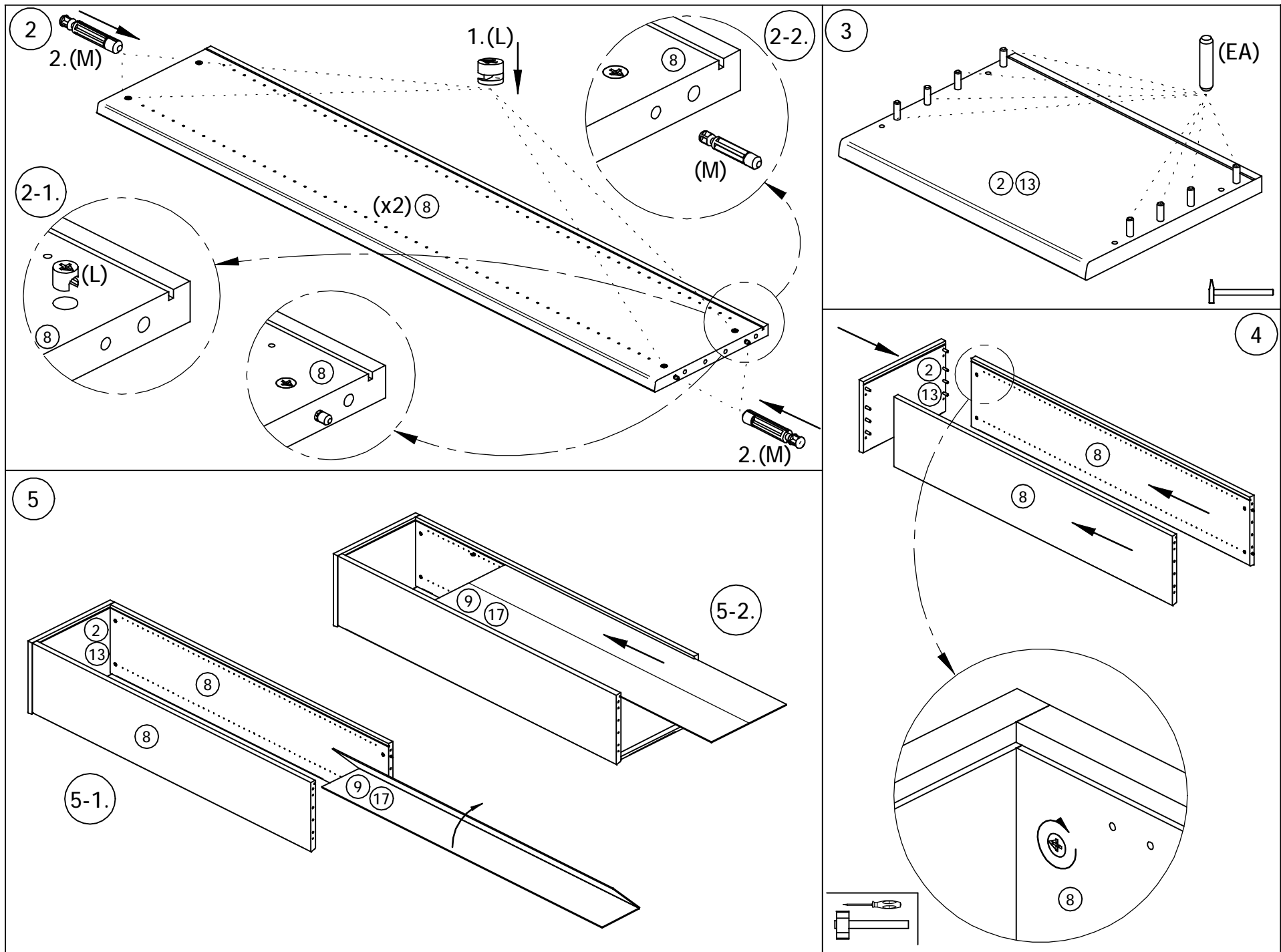
POINT 83

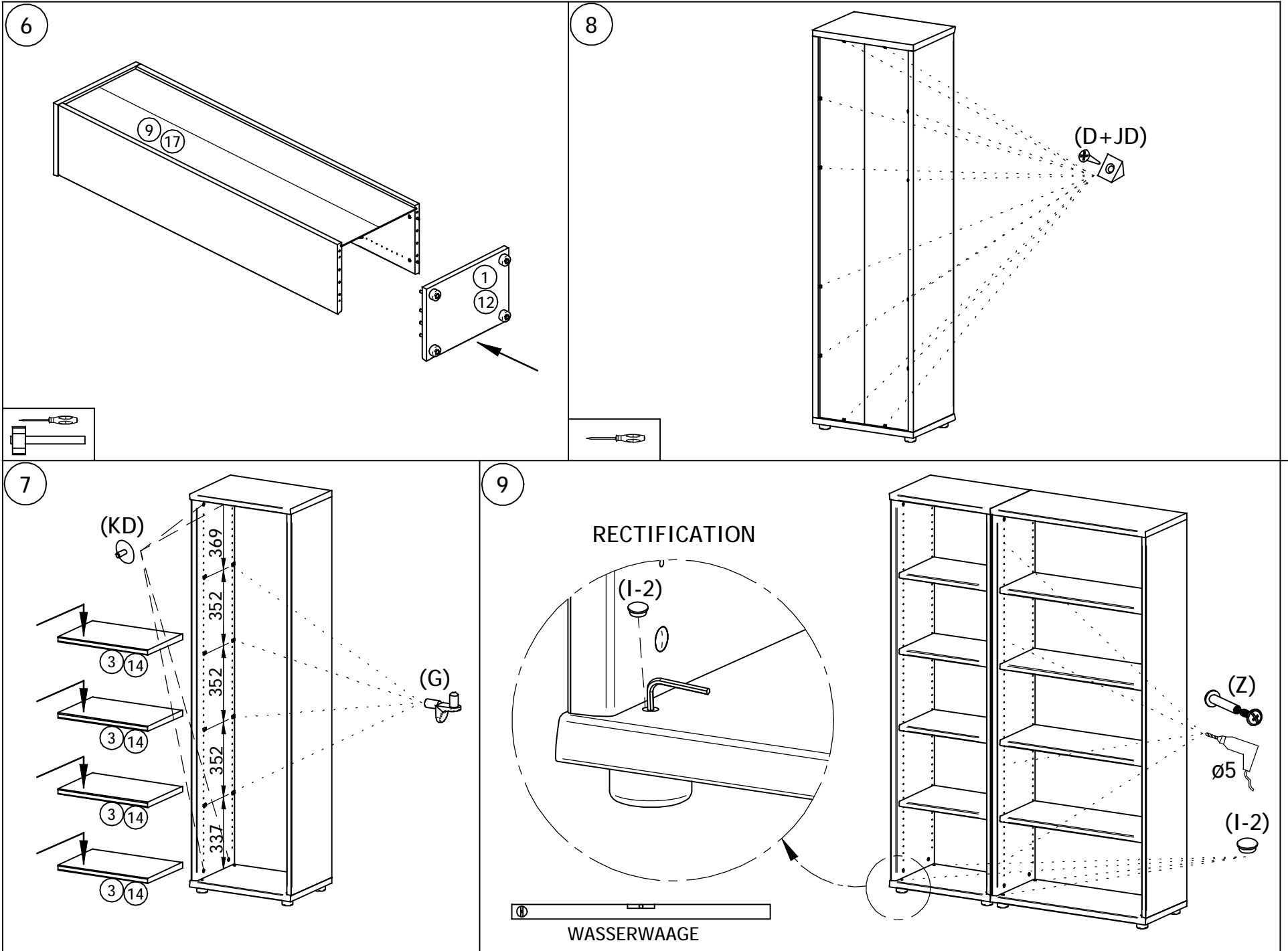



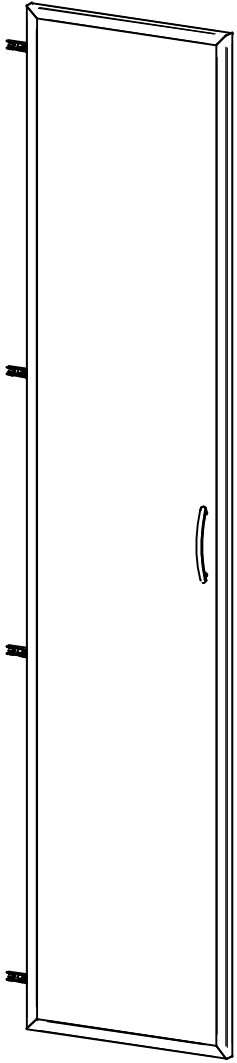
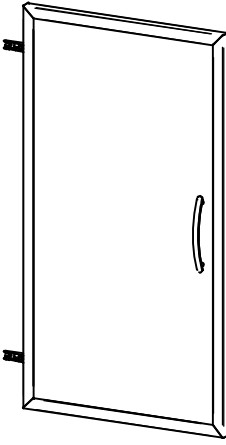
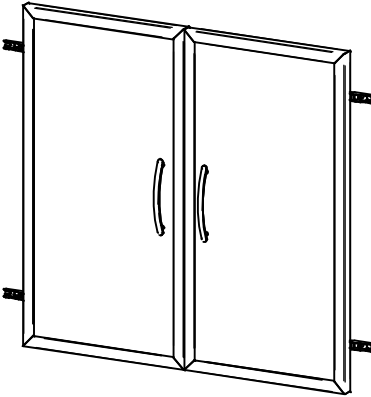
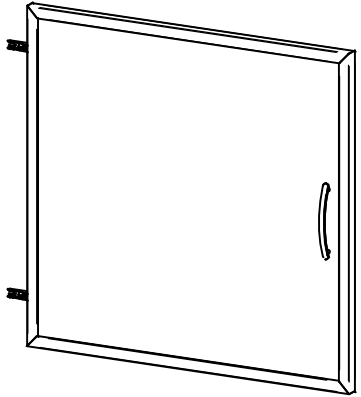

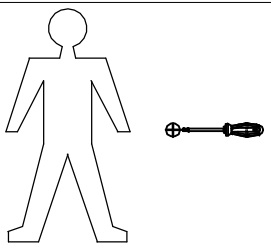
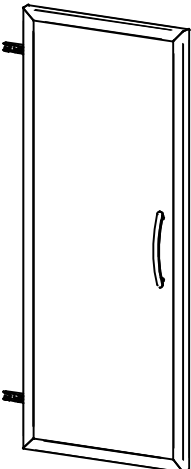
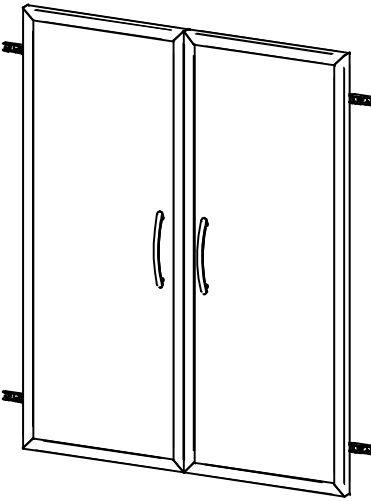
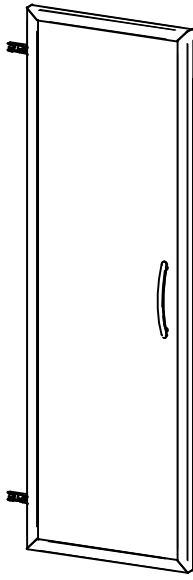

MONTAGEANLEITUNG / MONTÁŽNY NÁVOD // SERVISKARTE / SERVISNÁ KARTA

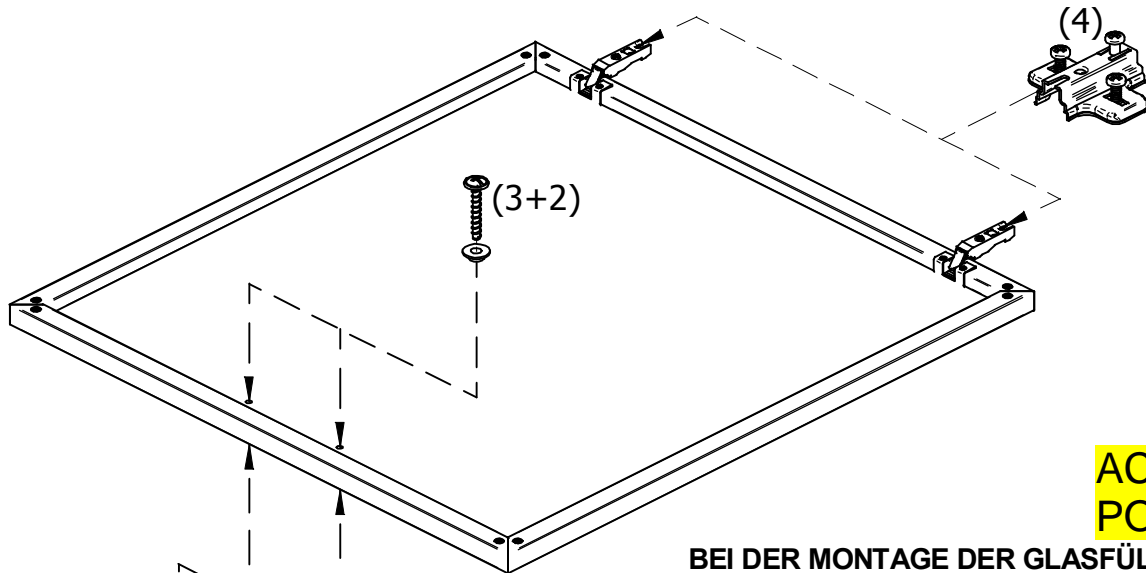
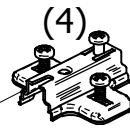
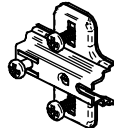
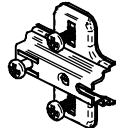
<p style="writing-mode: vertical-rl; transform: rotate(180deg);">POINT TYPE-T 54 AG/TYP-T 54 AG</p> 	<p style="writing-mode: vertical-rl; transform: rotate(180deg);">POINT TYPE-T 501 AG/TYP-T 501 AG</p> 	<p style="writing-mode: vertical-rl; transform: rotate(180deg);">POINT TYPE-T 80 AG/TYP-T 80 AG</p> 	<p style="writing-mode: vertical-rl; transform: rotate(180deg);">POINT TYPE-T 800 AG/TYP-T 800 AG</p> 	1	 <p>T 501 AG-x1 T 51 AG -x1 T 800 AG-x1 T 53 AG -x2 T 54 AG -x2 T 80 AG -x2 T 81 AG -x2</p>
	<p style="writing-mode: vertical-rl; transform: rotate(180deg);">POINT TYPE-T 51 AG/TYP-T 51 AG</p> 	<p style="writing-mode: vertical-rl; transform: rotate(180deg);">POINT TYPE-T 81 AG/TYP-T 81 AG</p> 	<p style="writing-mode: vertical-rl; transform: rotate(180deg);">POINT TYPE-T 53 AG/TYP-T 53 AG</p> 	2	<p>M4x10</p>  <p>T 501 AG-x2 T 51 AG -x2 T 800 AG x2 T 53 AG -x4 T 54 AG -x4 T 80 AG -x4 T 81 AG -x4</p>

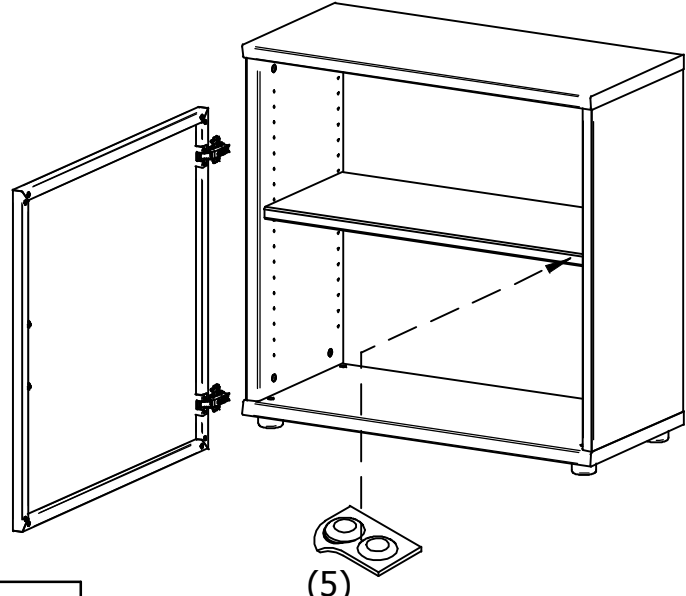
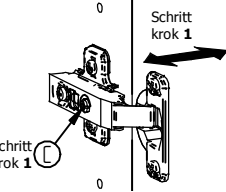
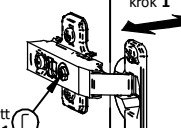
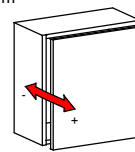
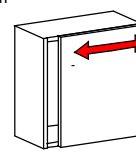
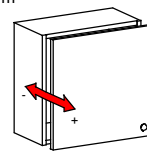
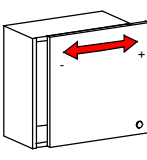
3	 T 501 AG-x2 T 51 AG -x2 T 800 AG x2 T 53 AG -x4 T 54 AG -x4 T 80 AG -x4 T 81 AG -x4		 ACHTUNG!!! POZOR!!!  BEI DER MONTAGE DER GLASFÜLLUNG UND DES GRIFFES BITTE NUR MANUELLEN SCHRAUBENZIEHER EINSETZEN. PRI MONTÁŽI SKLENENEJ VÝPLNE A ÚCHYTKY POUŽÍVAJTE LEN RUČNÝ SKRUTKOVÁČ.															
4	 T 501 AG-x2 T 51 AG -x2 T 800 AG x2 T 53 AG -x4 T 54 AG -x4 T 80 AG -x4 T 81 AG -x4																	
5	 T 501 AG-x2 T 51 AG -x2 T 800 AG x2 T 53 AG -x4 T 54 AG -x4 T 80 AG -x4 T 81 AG -x4		<h3>Einstellung von Türen / Nastavenie dverí</h3> <table border="1"> <tbody> <tr> <td data-bbox="1299 925 1534 1125">  Schritt krok 1-3 B 0 Schritt krok 2 </td> <td data-bbox="1541 925 1776 1125">  Schritt krok 1-3 A 0 Schritt krok 2 </td> <td data-bbox="1783 925 2038 1125">  Schritt krok 1 L 0 Schritt krok 1 </td> </tr> <tr> <td data-bbox="1299 1129 1534 1284"> 1. Die Schraube B lösen 2. Tür in der Höhe einstellen 3. Die Schraube B zuziehen </td> <td data-bbox="1541 1129 1776 1284"> 1. Die Schraube A lösen 2. Tür in der Tiefe einstellen 3. Die Schraube A zuziehen </td> <td data-bbox="1783 1129 2038 1284"> 1. Tür seitlgs mit Schraube C einstellen </td> </tr> <tr> <td data-bbox="1299 1289 1534 1444"> 1. skrutku B povoliť 2. dvere výškovo nastaviť 3. skrutku B dotiahnuť </td> <td data-bbox="1541 1289 1776 1444"> 1. skrutku A povoliť 2. dvere hĺbkovo nastaviť 3. skrutku A dotiahnuť </td> <td data-bbox="1783 1289 2038 1444"> 1. dvere stranovo skrutkou C nastaviť </td> </tr> <tr> <td data-bbox="1299 1449 1534 1500"> + 2 mm - 2 mm </td> <td data-bbox="1541 1449 1776 1500"> + 3 mm - 1 mm </td> <td data-bbox="1783 1449 2038 1500"> + 5 mm - 1,5 mm </td> </tr> <tr> <td data-bbox="1299 1505 1534 1511">  </td> <td data-bbox="1541 1505 1776 1511">  </td> <td data-bbox="1783 1505 2038 1511">  </td> </tr> </tbody> </table>	 Schritt krok 1-3 B 0 Schritt krok 2	 Schritt krok 1-3 A 0 Schritt krok 2	 Schritt krok 1 L 0 Schritt krok 1	1. Die Schraube B lösen 2. Tür in der Höhe einstellen 3. Die Schraube B zuziehen	1. Die Schraube A lösen 2. Tür in der Tiefe einstellen 3. Die Schraube A zuziehen	1. Tür seitlgs mit Schraube C einstellen	1. skrutku B povoliť 2. dvere výškovo nastaviť 3. skrutku B dotiahnuť	1. skrutku A povoliť 2. dvere hĺbkovo nastaviť 3. skrutku A dotiahnuť	1. dvere stranovo skrutkou C nastaviť	+ 2 mm - 2 mm	+ 3 mm - 1 mm	+ 5 mm - 1,5 mm			
 Schritt krok 1-3 B 0 Schritt krok 2	 Schritt krok 1-3 A 0 Schritt krok 2	 Schritt krok 1 L 0 Schritt krok 1																
1. Die Schraube B lösen 2. Tür in der Höhe einstellen 3. Die Schraube B zuziehen	1. Die Schraube A lösen 2. Tür in der Tiefe einstellen 3. Die Schraube A zuziehen	1. Tür seitlgs mit Schraube C einstellen																
1. skrutku B povoliť 2. dvere výškovo nastaviť 3. skrutku B dotiahnuť	1. skrutku A povoliť 2. dvere hĺbkovo nastaviť 3. skrutku A dotiahnuť	1. dvere stranovo skrutkou C nastaviť																
+ 2 mm - 2 mm	+ 3 mm - 1 mm	+ 5 mm - 1,5 mm																
																		

POINT T50
 POINT T51
 POINT T501

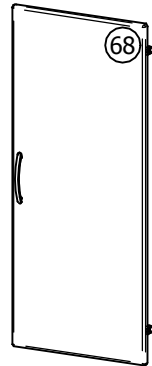
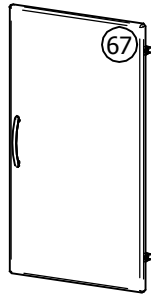
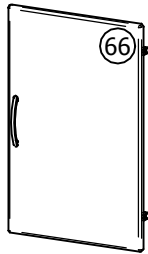

 AA		KE	x2	JA	$\varnothing 3.5 \times 15$ x4	AC	M4x25 x2	x1	x2	x2
								B	C	

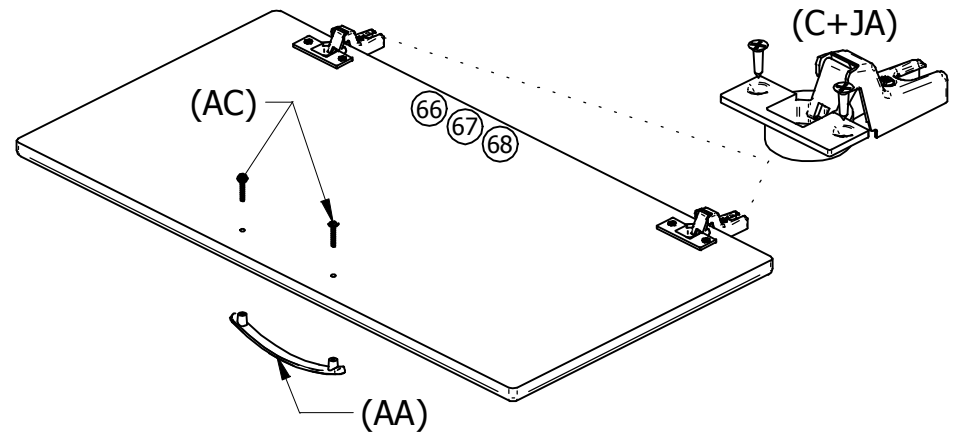

1

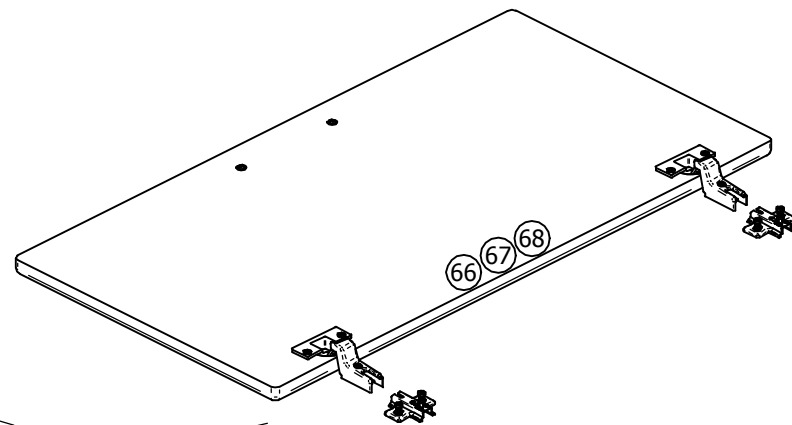
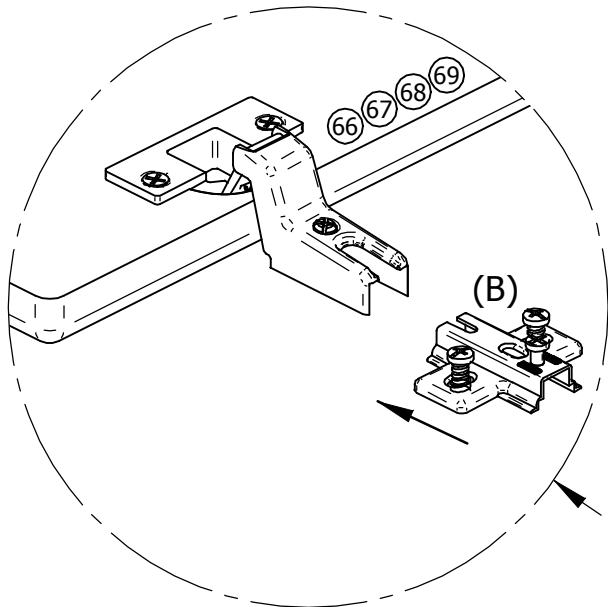

2

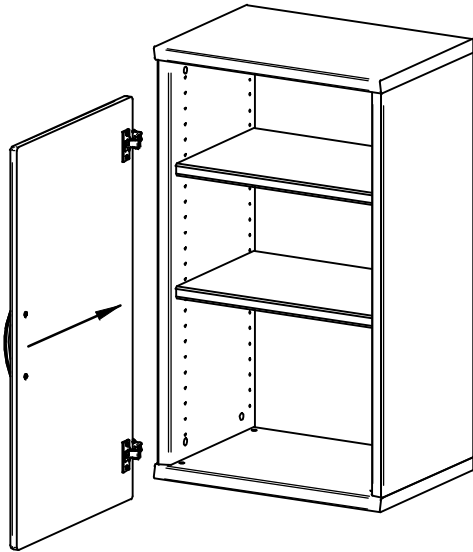

3

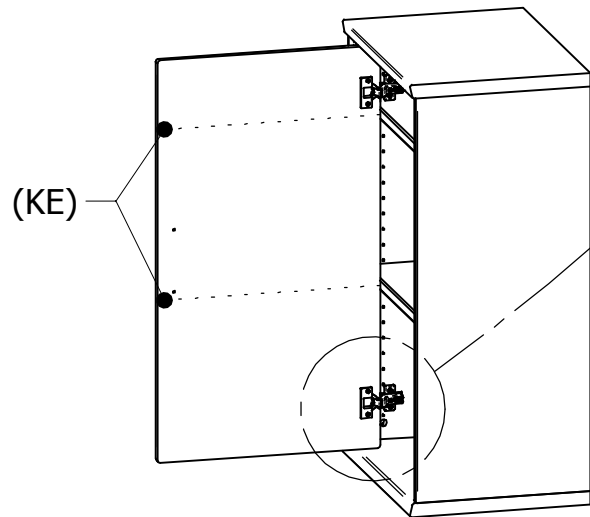
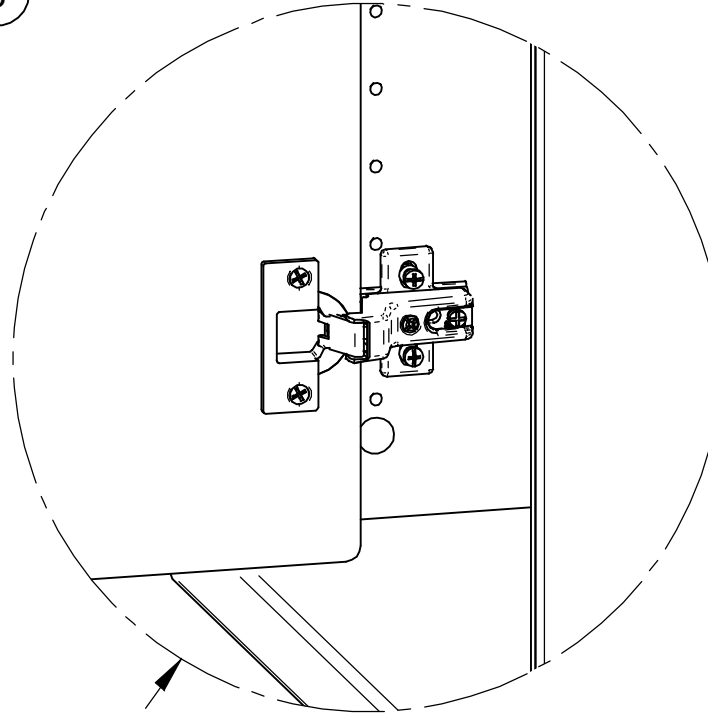
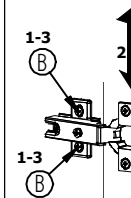
NASTAVENIE DVERI / EINSTELLUNG VON TUREN

- 1: SKRUTKU B POVOLIT
DIE SCHRAUBEN B LOSEN
- 2: DVERE VYSKOVO NASTAVIT
TUR IN DER HOHE JUSTIEREN
- 3: SKRUTKU B DOTIAHNUT
DIE SCHRAUBEN B ANZIEHEN

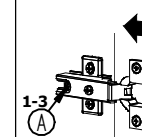

- 1: SKRUTKU A POVOLIT
DIE SCHRAUBEN A LOSEN
- 2: DVERE HLBKOVO NASTAVIT
TUR IN DER TIEFE JUSTIEREN
- 3: SKRUTKU A DOTIAHNUT
SCHRAUBEN A ANZIEHEN

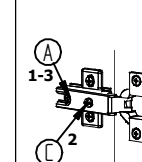

- 1: SKRUTKU A POVOLIT
DIE SCHRAUBEN A LOSEN
- 2: DVERE STRANOVO SKRUTKOU C
NASTAVIT
TUR SEITLIGS MIT SCHRAUBE C
JUSTIEREN
- 3: SKRUTKU A DOTIAHNUT
SCHRAUBE A ANZIEHEN

