

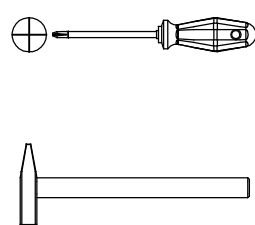

# TIROL

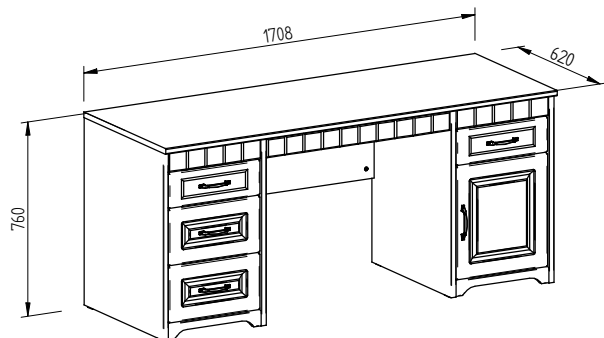

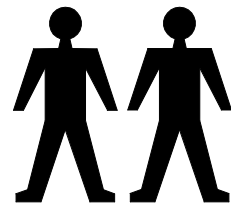
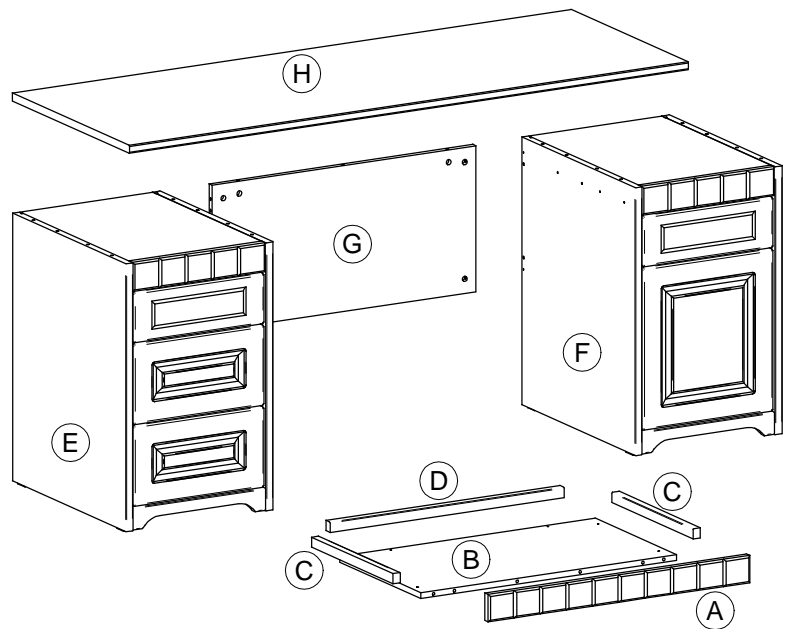

## 62

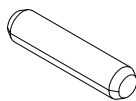
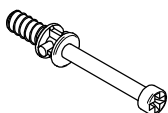

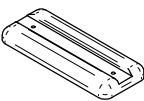
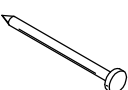
MN 163/12

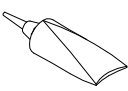

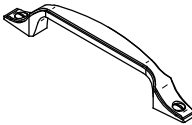
<b>1</b> $\varnothing 8 \times 35$ x19 	<b>2</b> $\varnothing 5$ x14 	<b>3</b> $\varnothing 15$ x14 	<b>4</b> $\varnothing 16$ x8 	<b>5</b> $\varnothing 1,2 \times 25$ x16 
---	---	--	---	---

<b>6</b> x3  Vor Gebrauch schütteln Shake before use Pred použitím zatrepaf	<b>7</b> $\varnothing 6,3 \times 11$ x12 	<b>8</b> M4x20 x10 	<b>9</b> x5 	<b>10</b> $\varnothing 4 \times 30$ x6 	<b>13</b> $\varnothing 5$ x4 
--	---	---	--	---	---

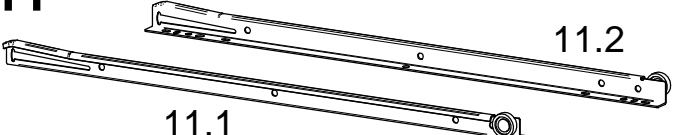
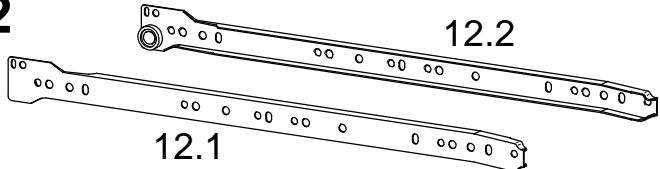
<b>11</b>  11.1      11.2	<b>12</b>  12.1      12.2
---	---

1.

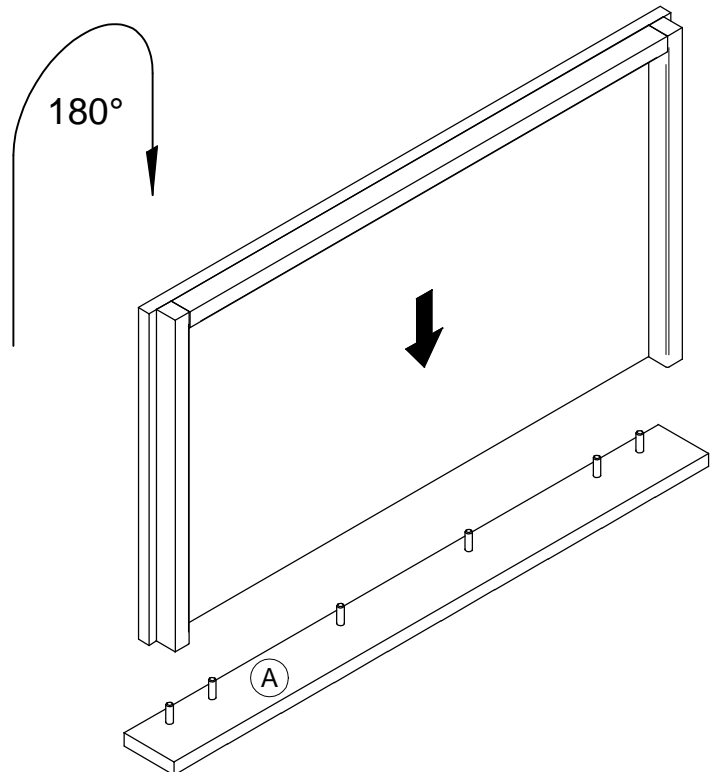
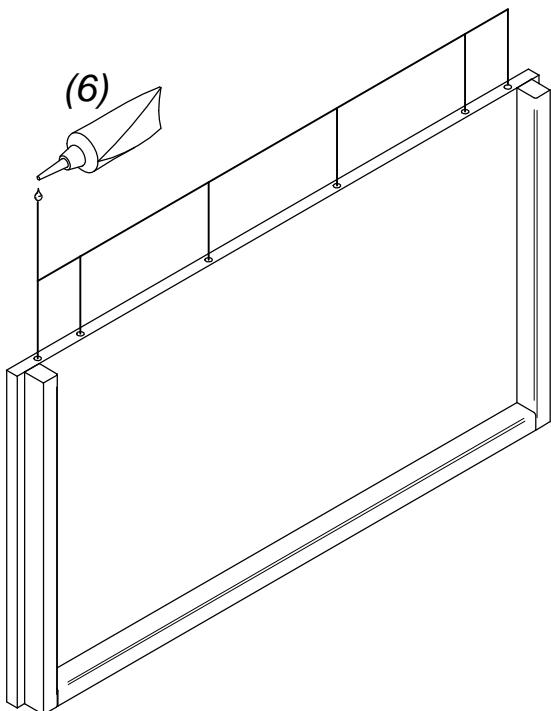
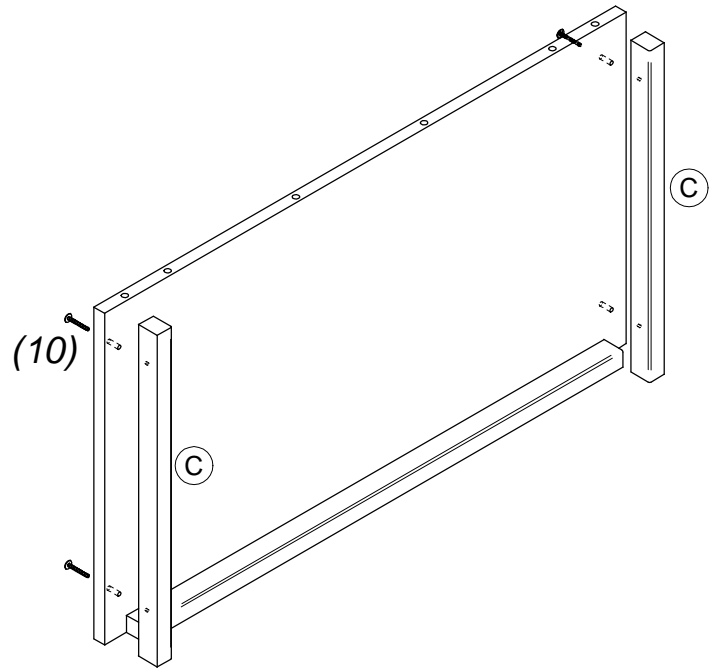
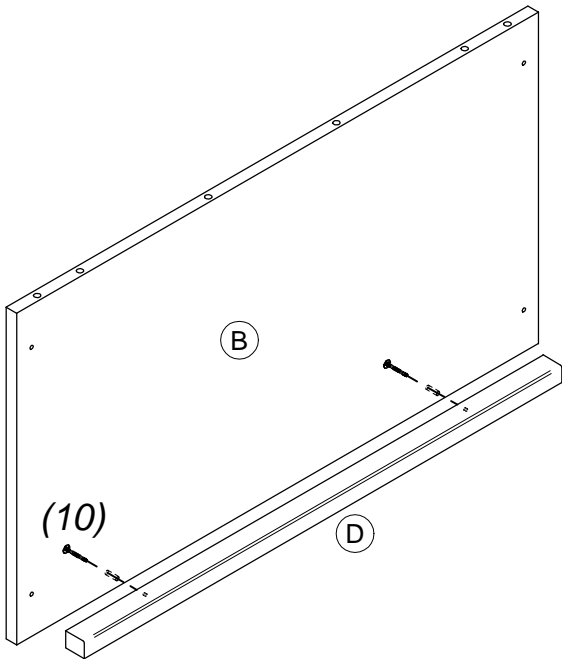
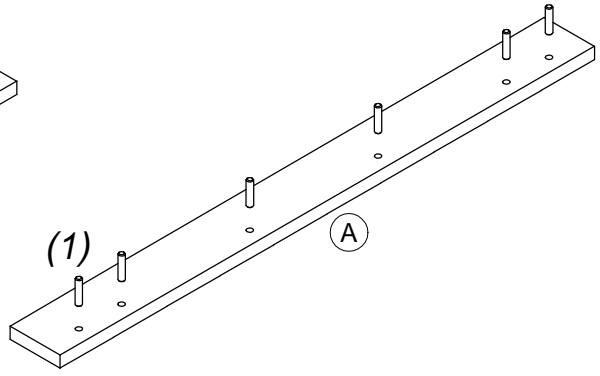
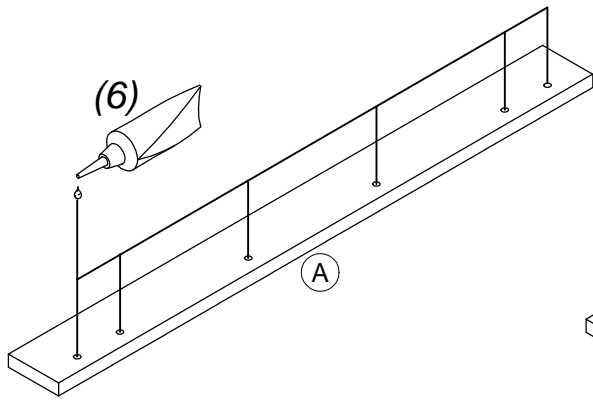

# 2.

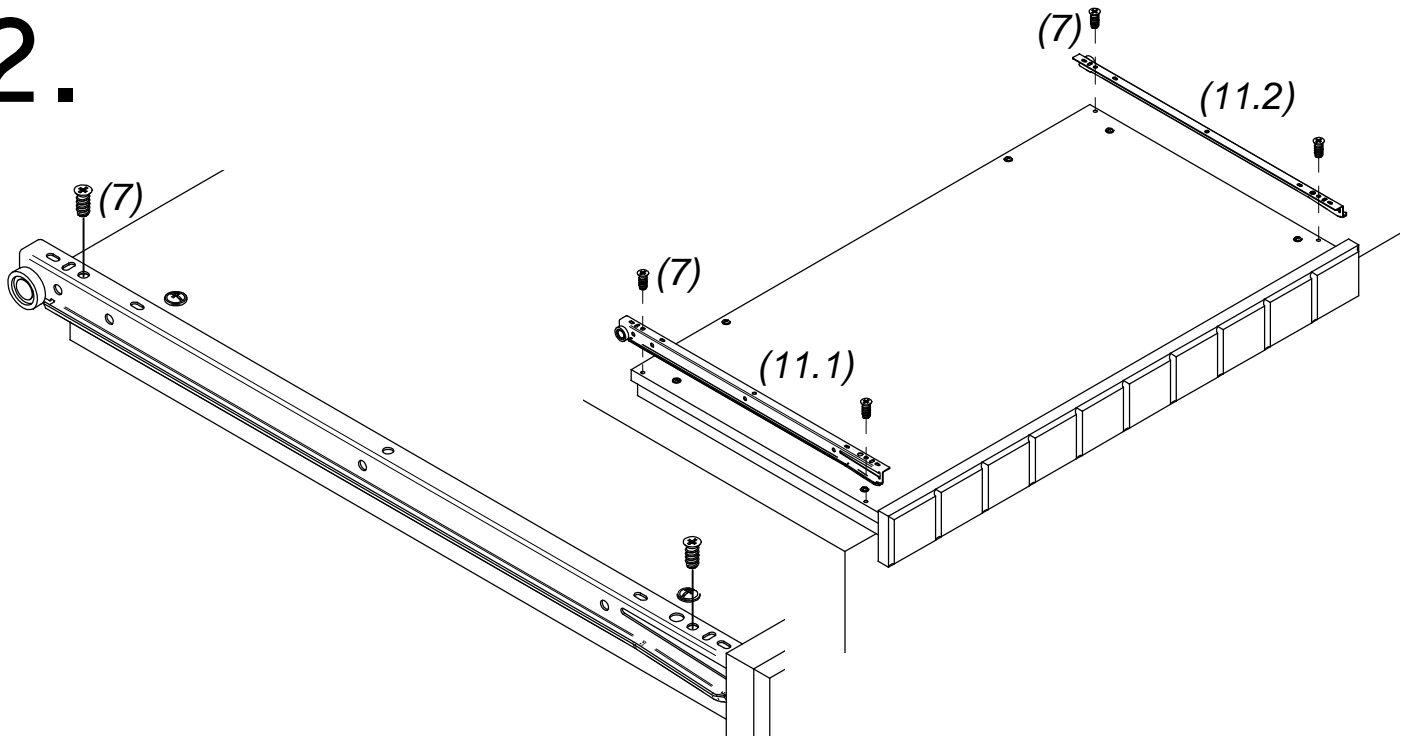

# 3.

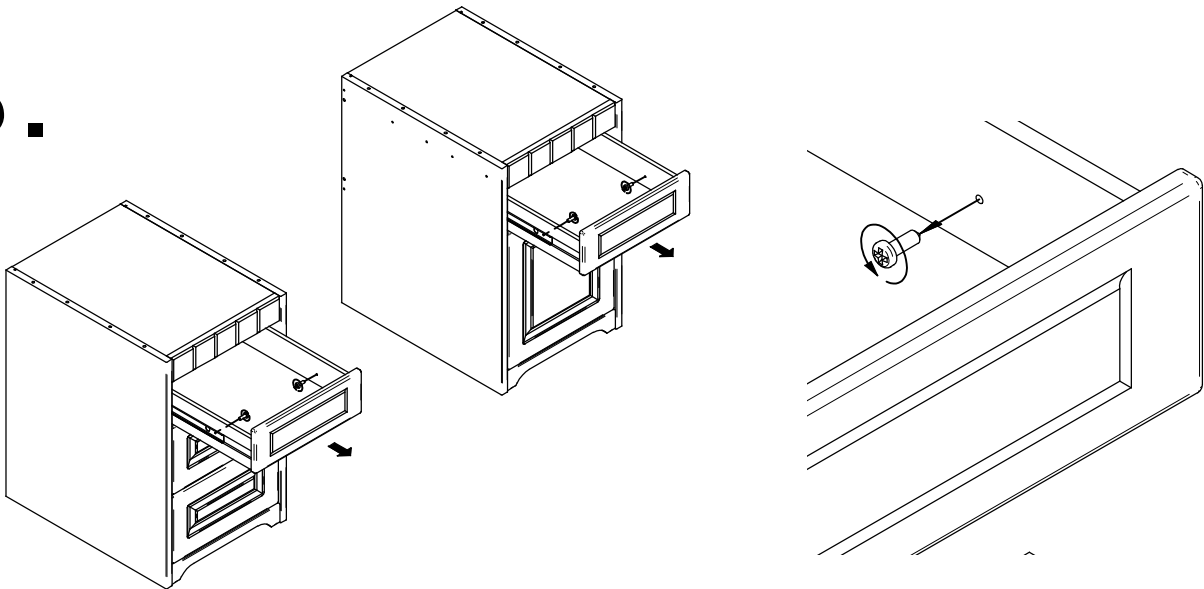

# 4.

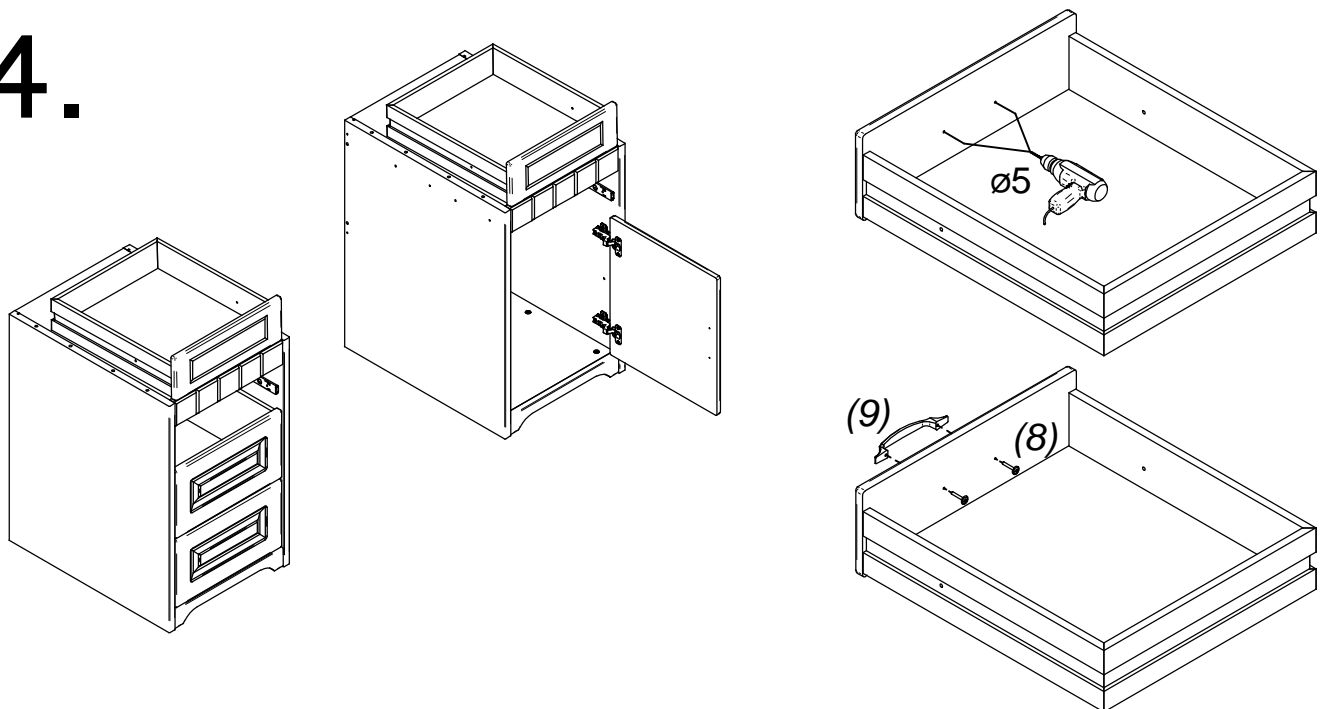

# 5.

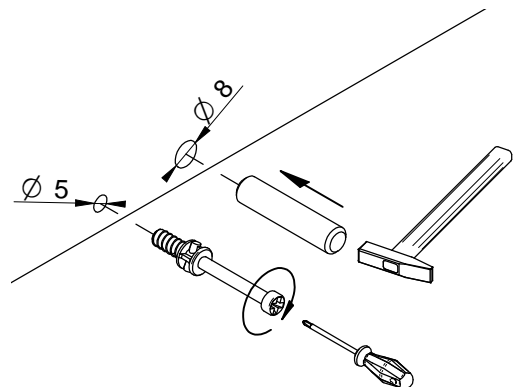
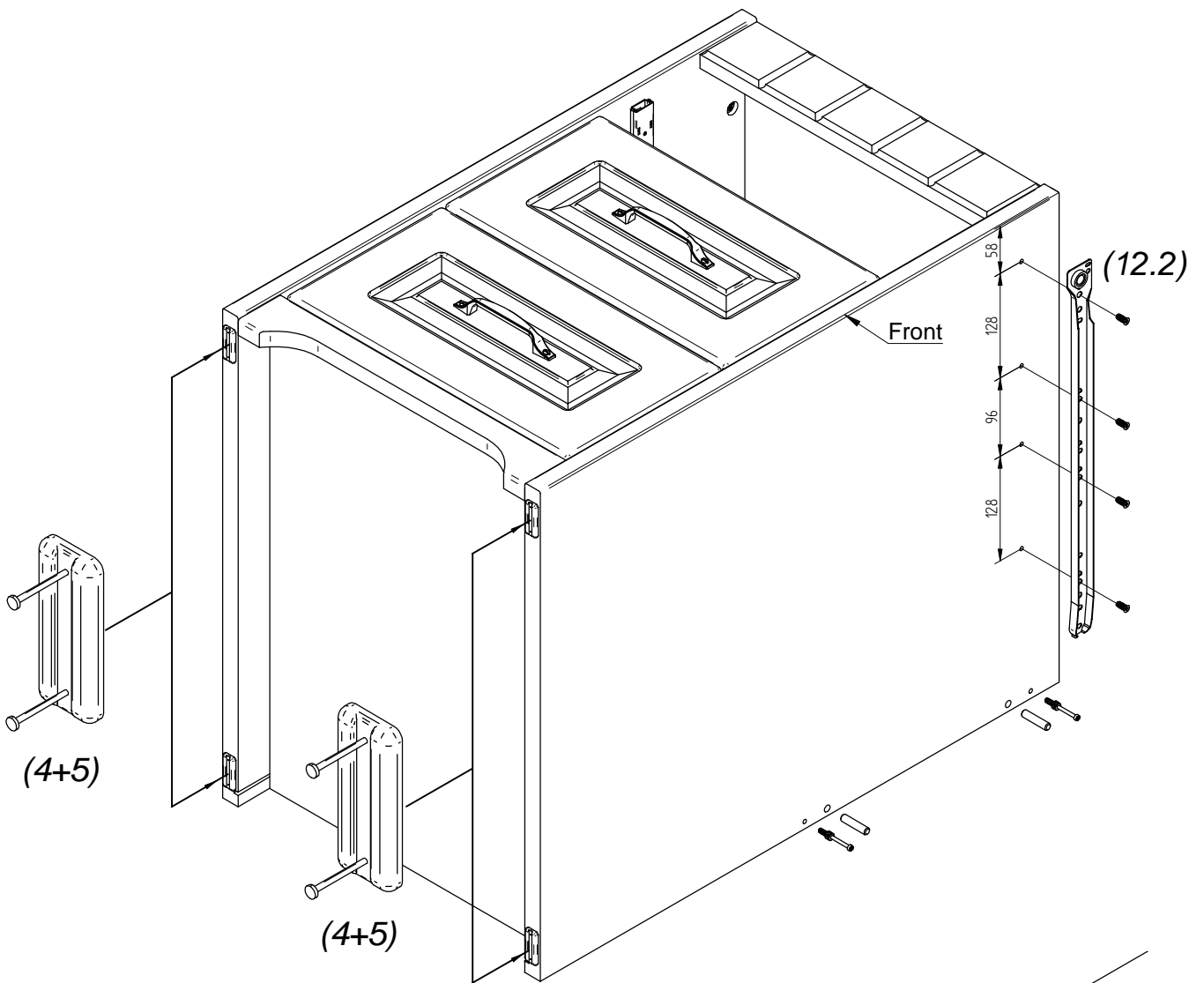
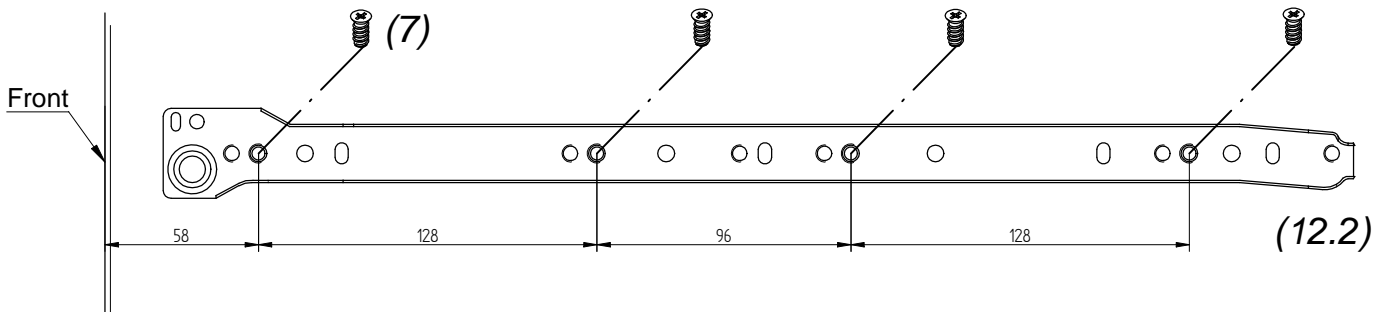

# 6.

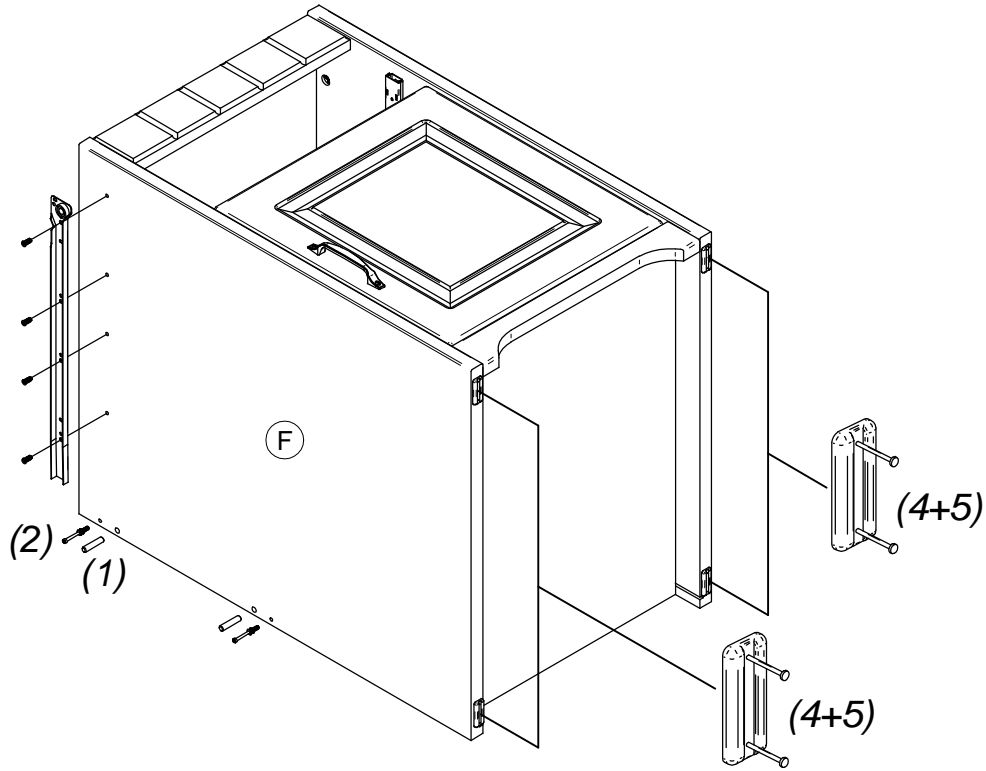
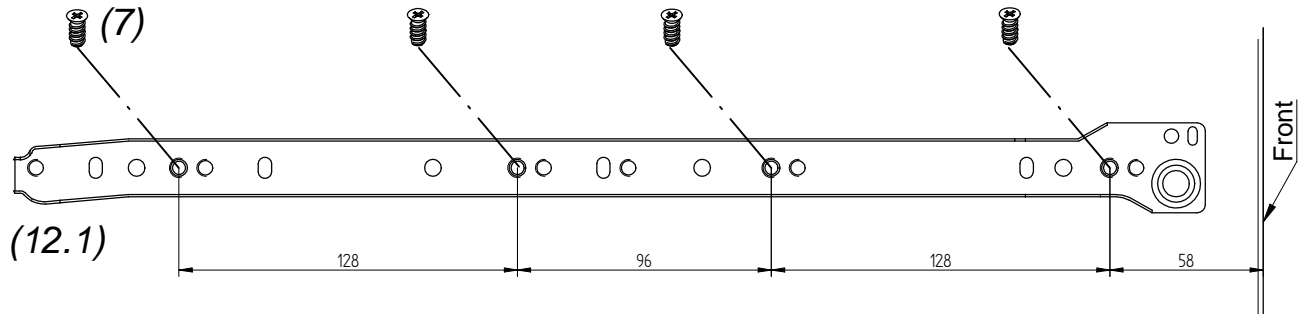

# 7.

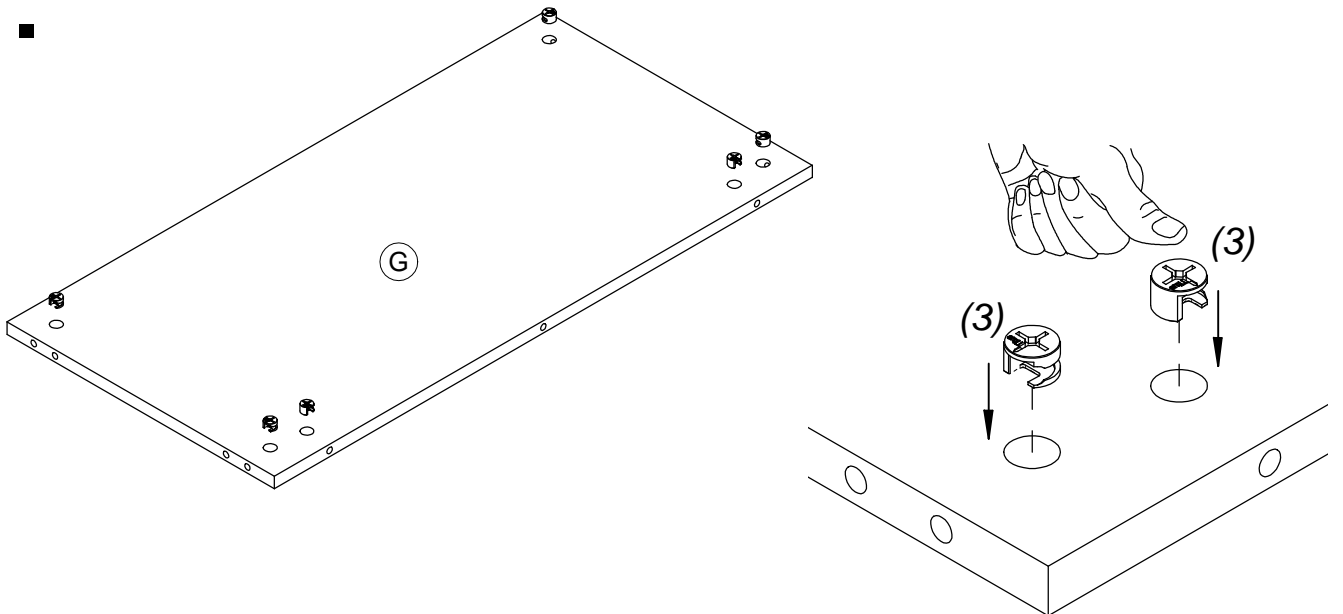

8.

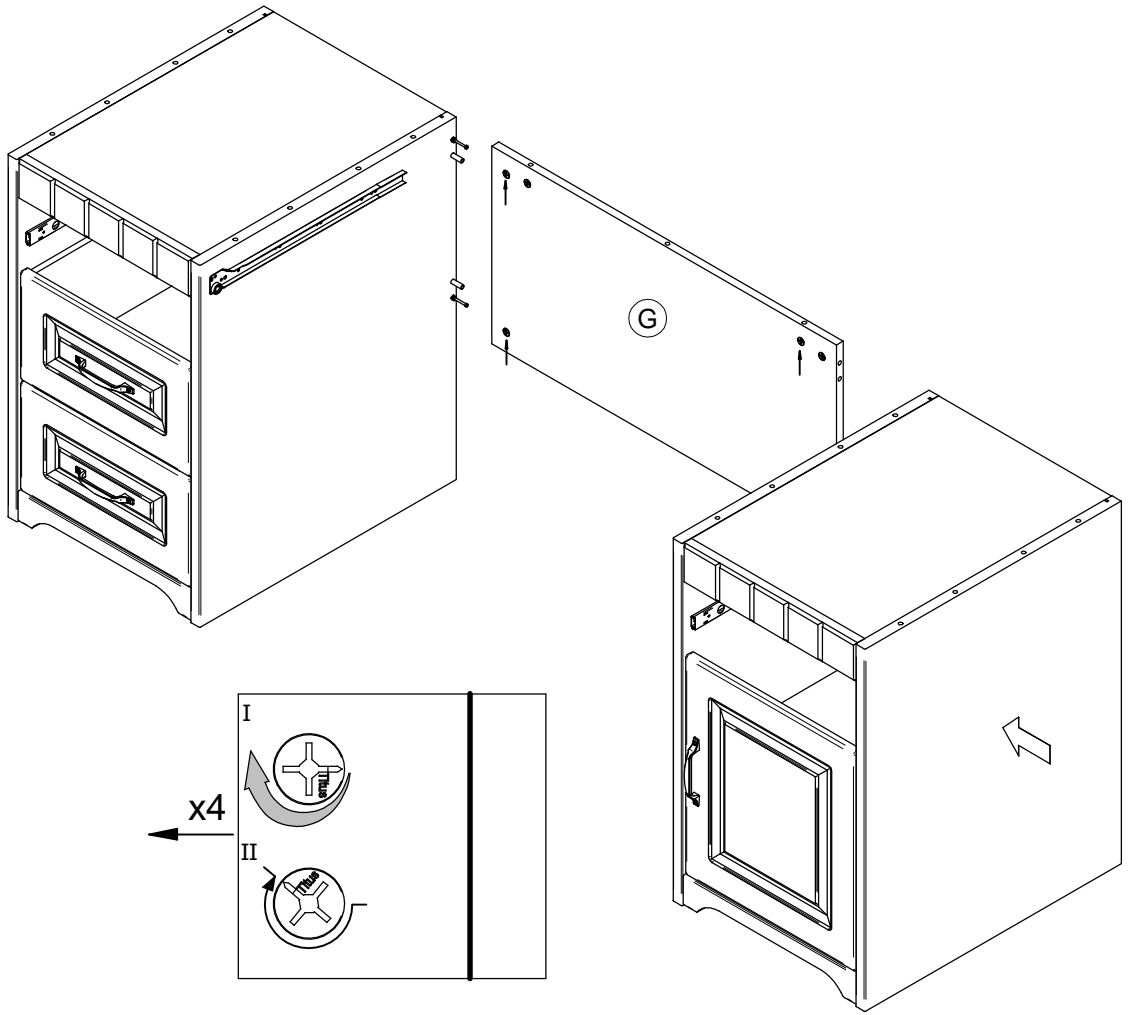

9.

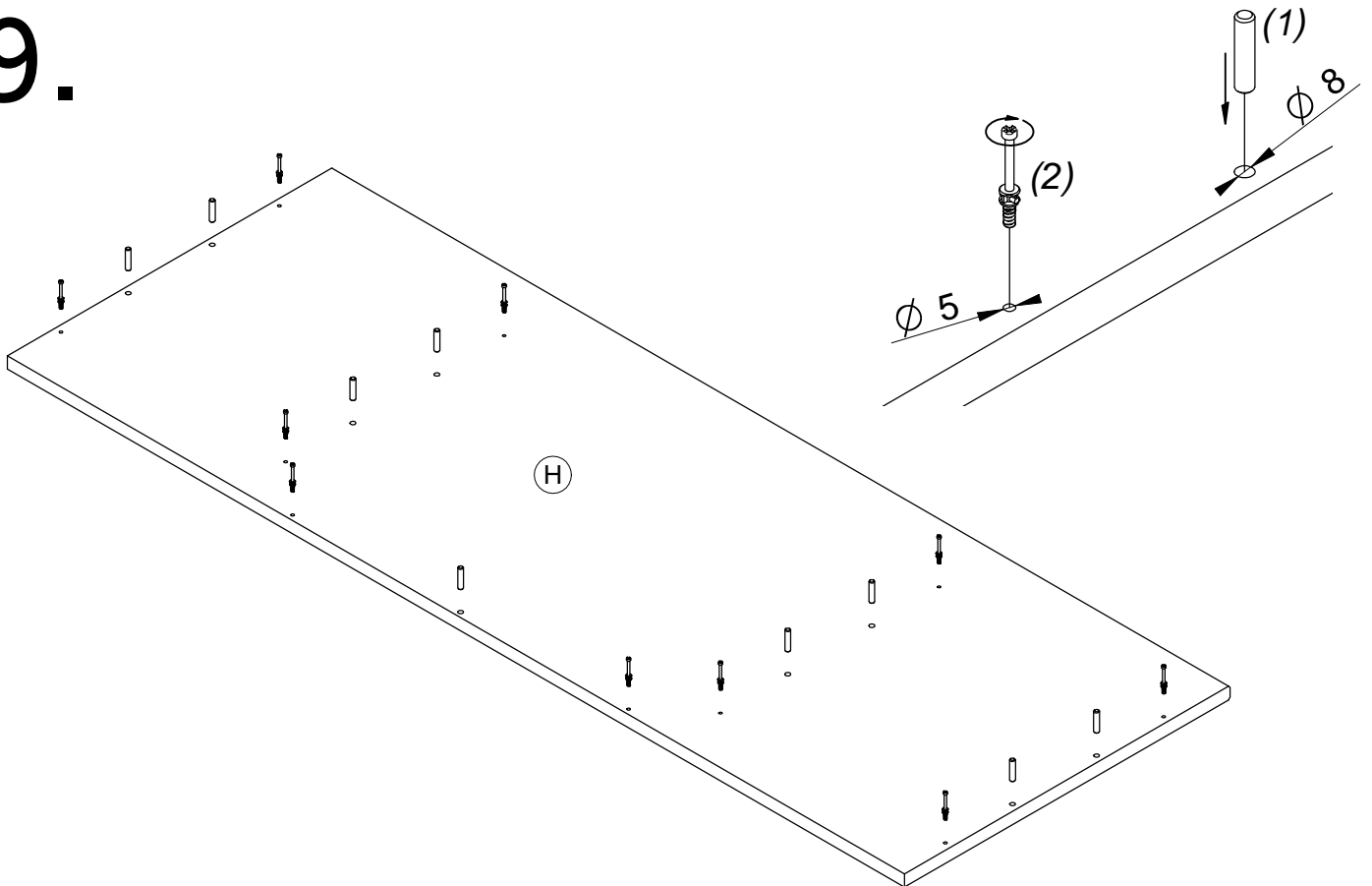

# 10.

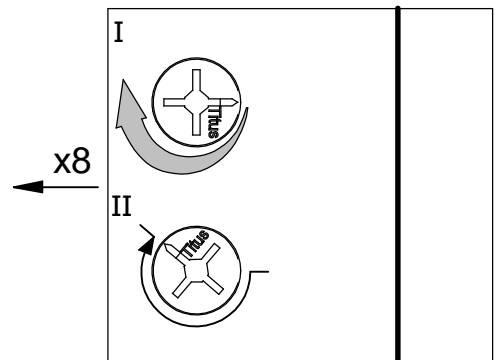
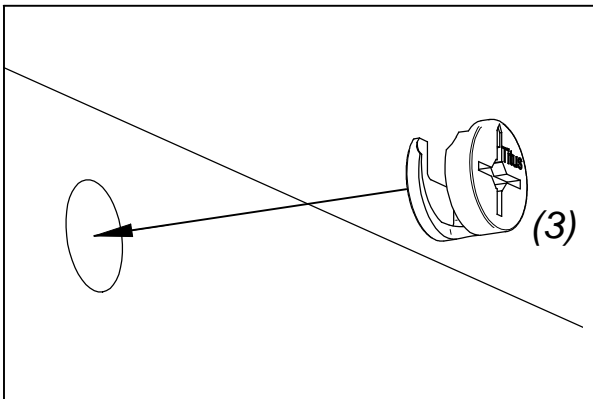
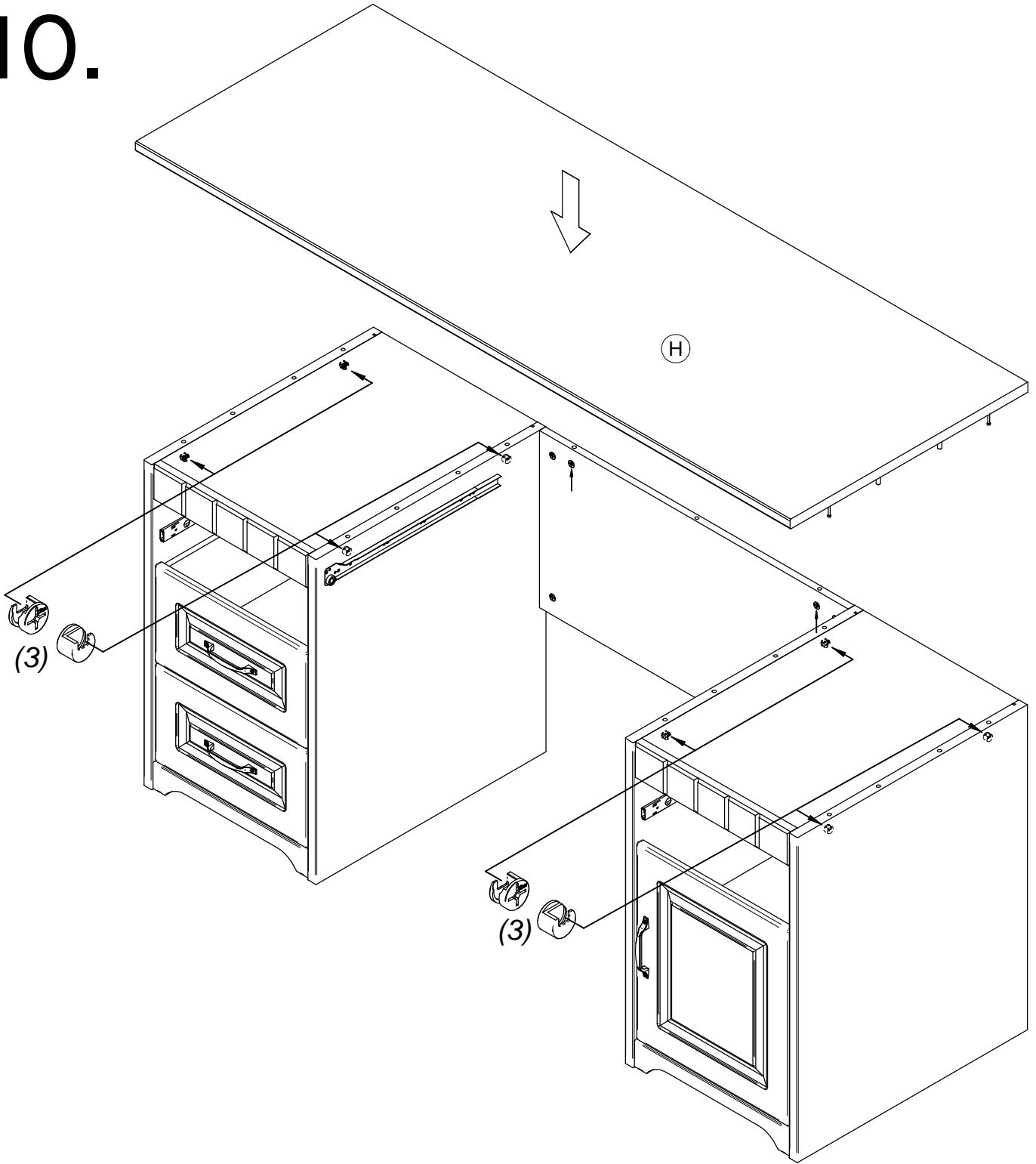

# 11.

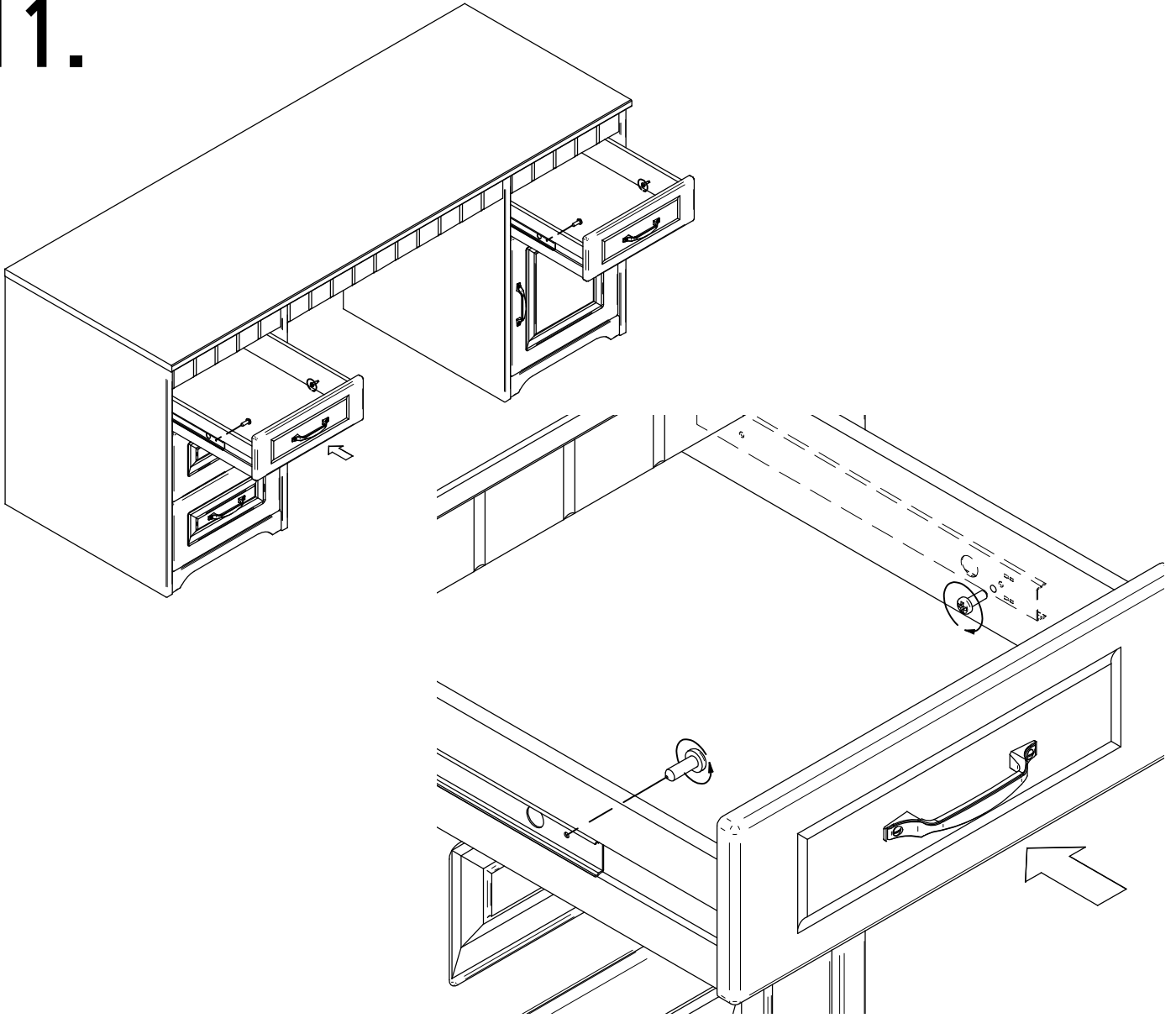

# 12.

