

12/003-1

### POINT 53

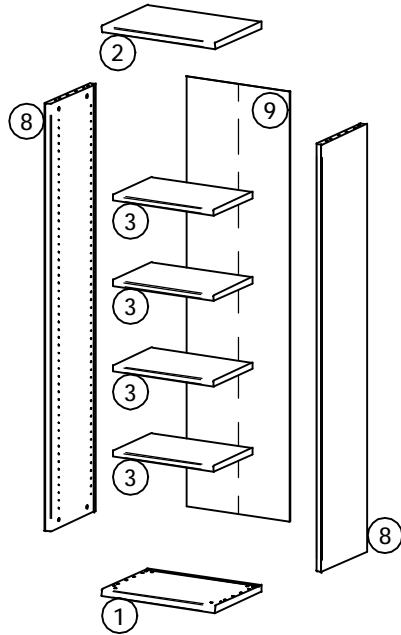

D	x12	EA	$\varnothing 10 \times 45$ x16	G	$\varnothing 5$ x16	I	x4
JD	$\varnothing 4 \times 25$ x12	L	$\varnothing 15$ x8	M	$\varnothing 8$ x8	Z	$\varnothing 5/2 \times 28$ x4
		KD	$\varnothing 15$ x8				

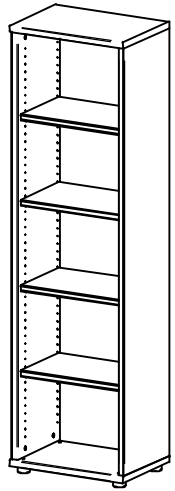
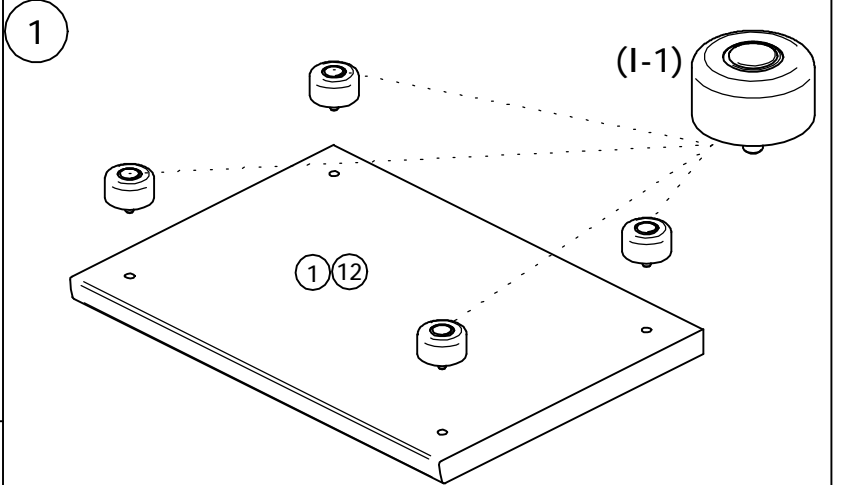
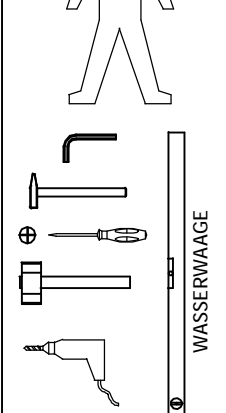

### POINT 83

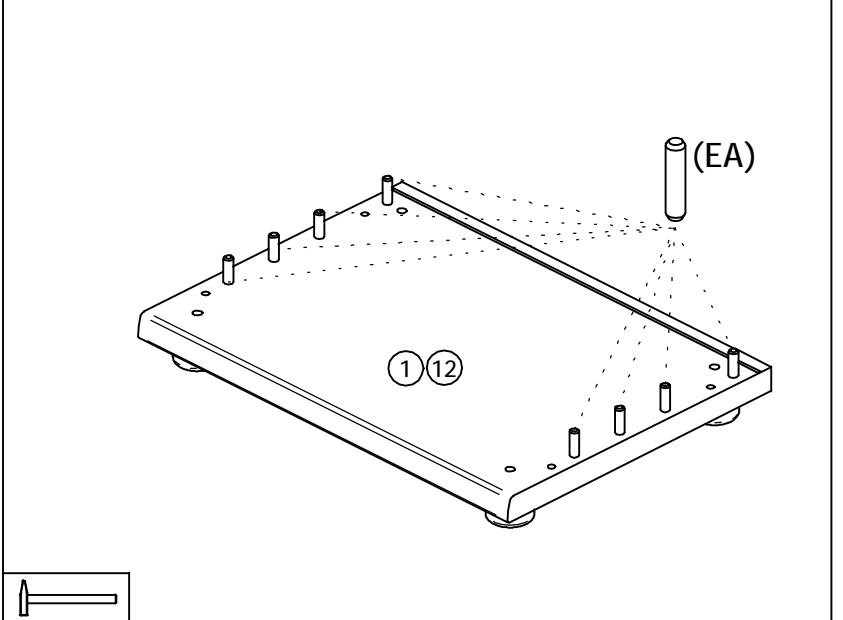
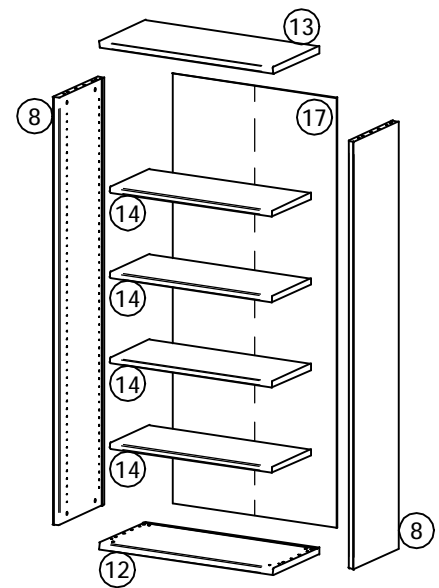
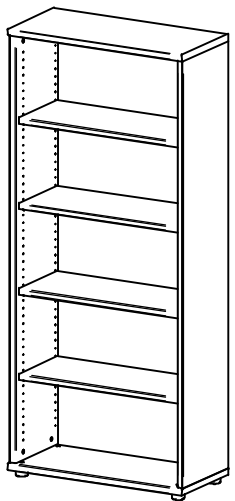

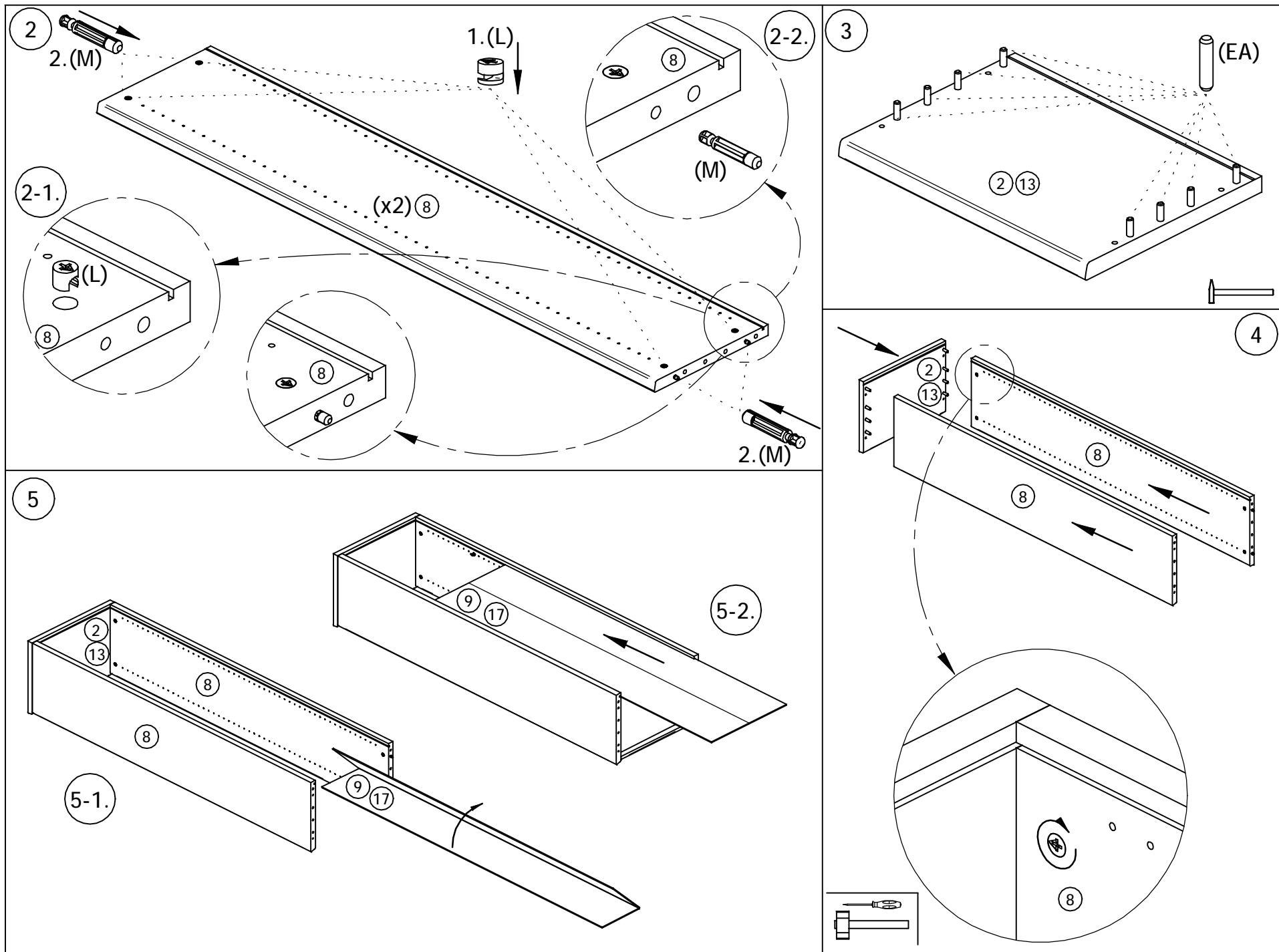

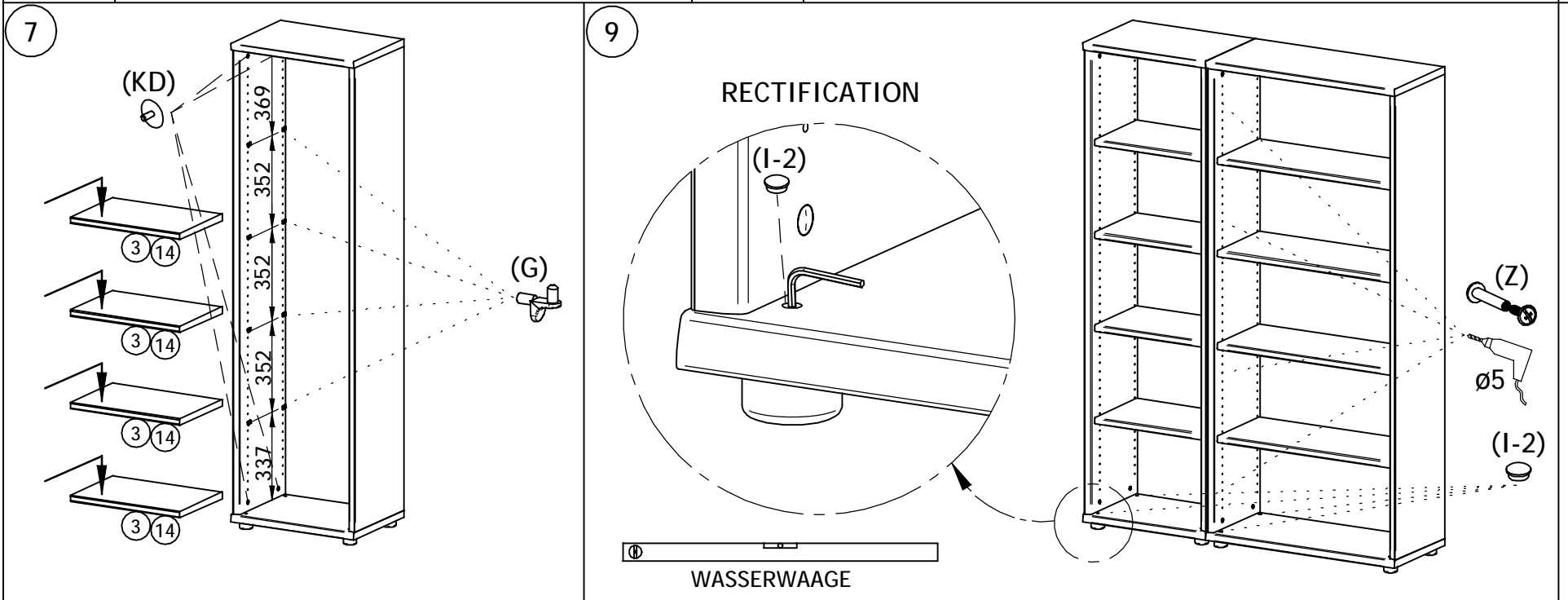
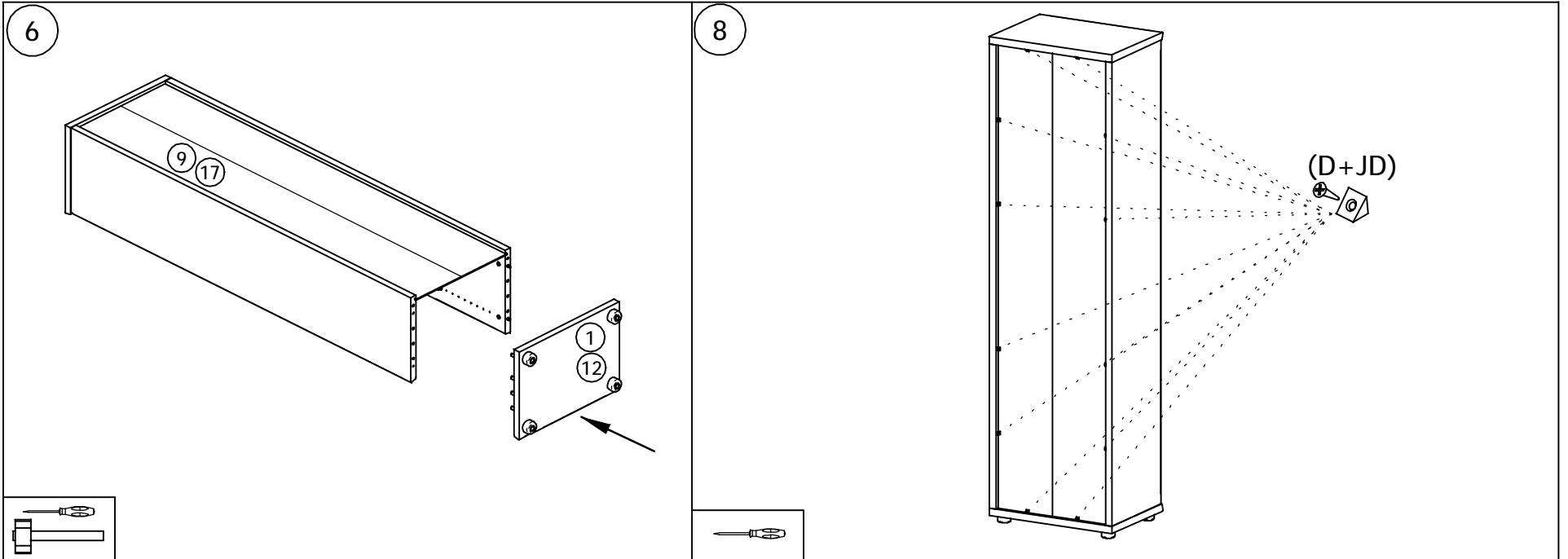

POINT T80  
 POINT T801  
 POINT T81

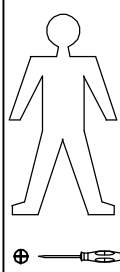

AA		x2	B		x4	C		x4
KE		x4	JA		ø3.5x15 x8	AC		M4x25 x4

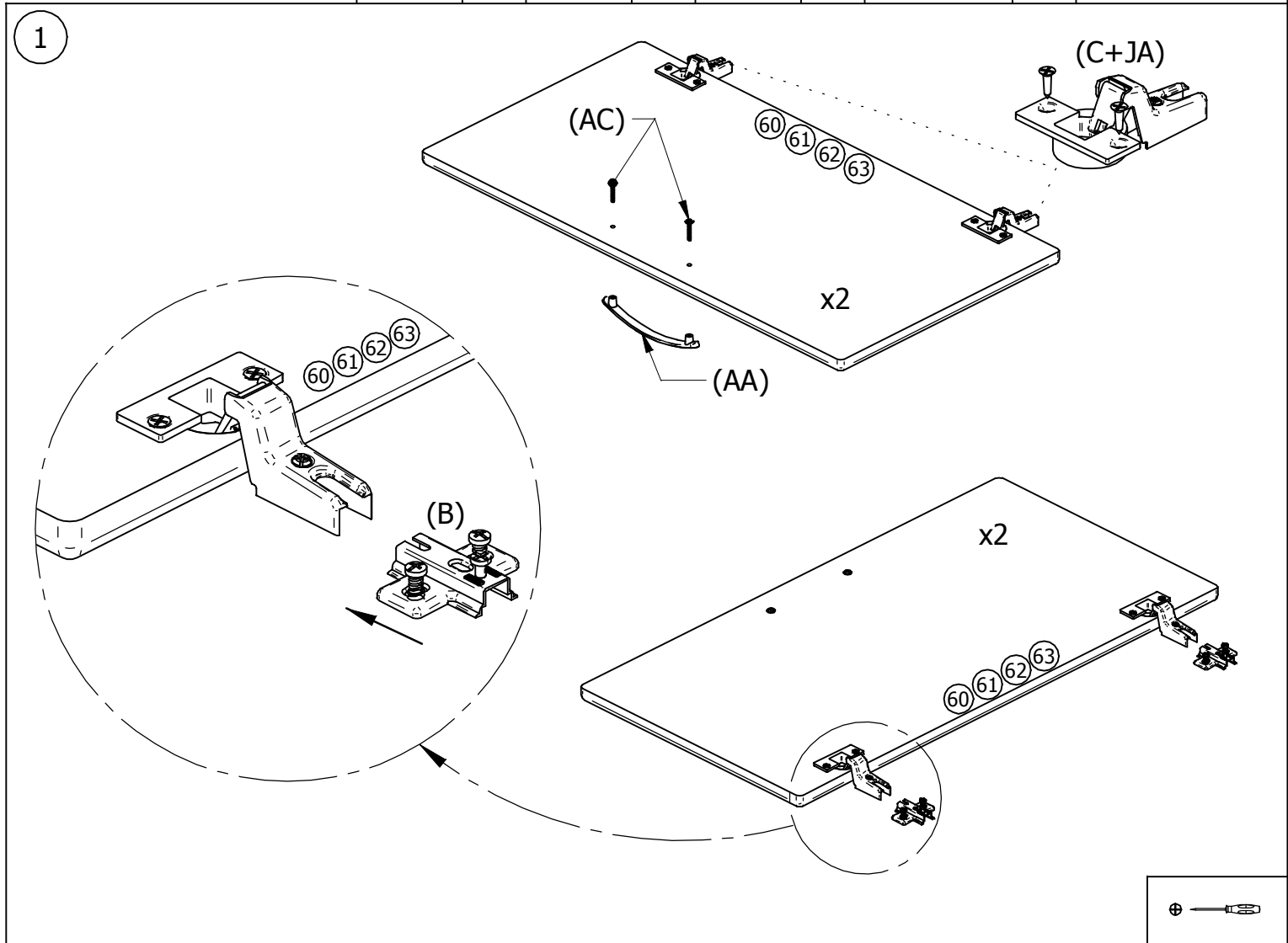
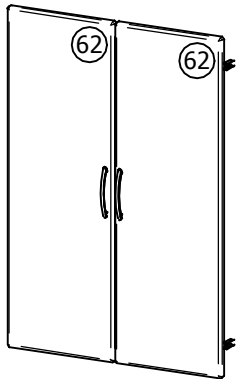
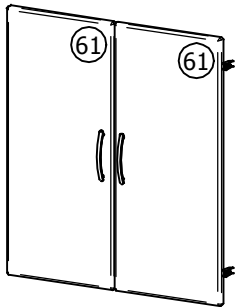
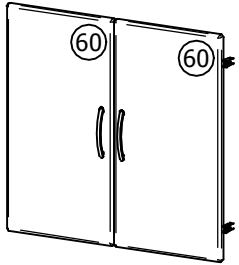

2

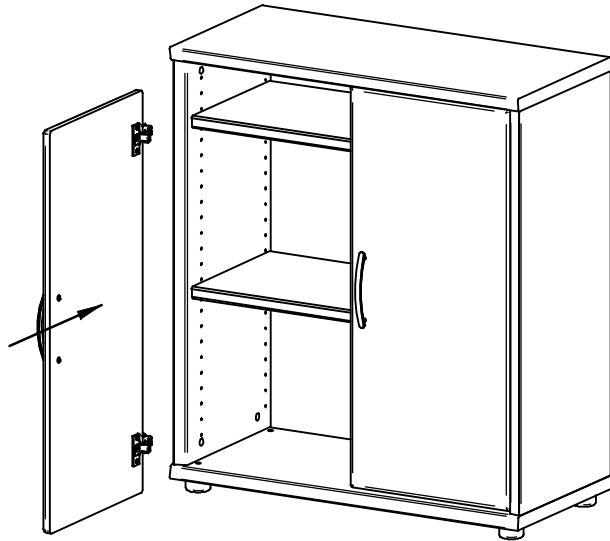

3

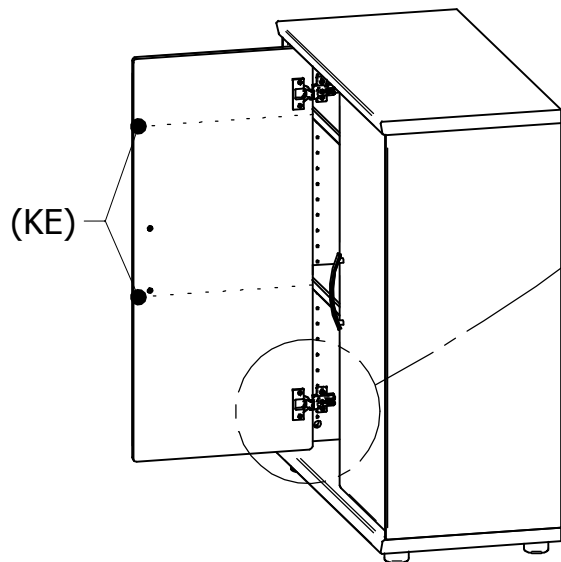
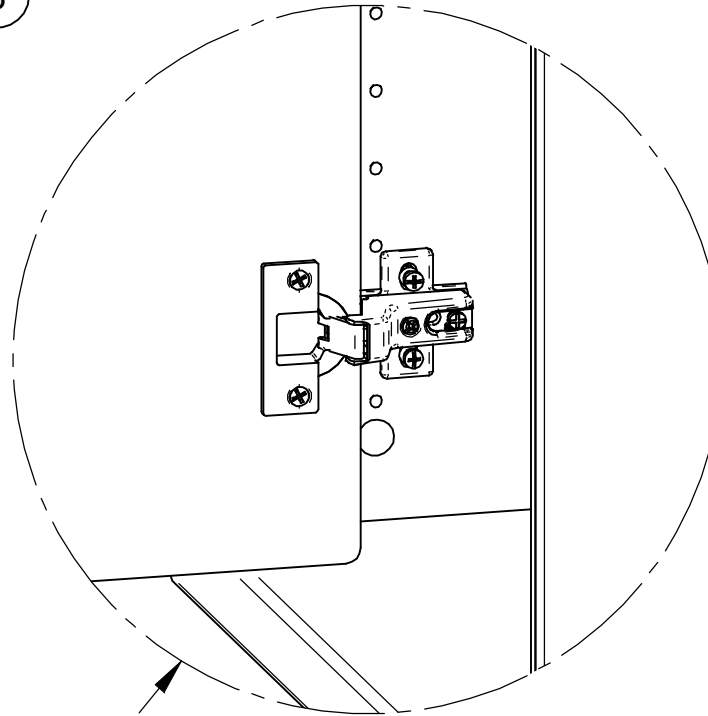
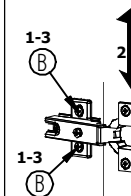
**NASTAVENIE DVERI / EINSTELLUNG VON TUREN**

- 1: SKRUTKU B POVOLIT  
DIE SCHRAUBEN B LOSEN
- 2: DVERE VYSKOVO NASTAVIT  
TUR IN DER HOHE JUSTIEREN
- 3: SKRUTKU B DOTIAHNUT  
DIE SCHRAUBEN B ANZIEHEN

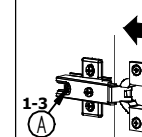

- 1: SKRUTKU A POVOLIT  
DIE SCHRAUBEN A LOSEN
- 2: DVERE HLBKOVO NASTAVIT  
TUR IN DER TIEFE JUSTIEREN
- 3: SKRUTKU A DOTIAHNUT  
SCHRAUBEN A ANZIEHEN

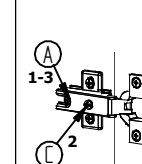

- 1: SKRUTKU A POVOLIT  
DIE SCHRAUBEN A LOSEN
- 2: DVERE STRANOVO SKRUTKOU C  
NASTAVIT  
TUR SEITLIGS MIT SCHRAUBE C  
JUSTIEREN
- 3: SKRUTKU A DOTIAHNUT  
SCHRAUBE A ANZIEHEN

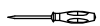

### POINT S 5X

### POINT S 8X

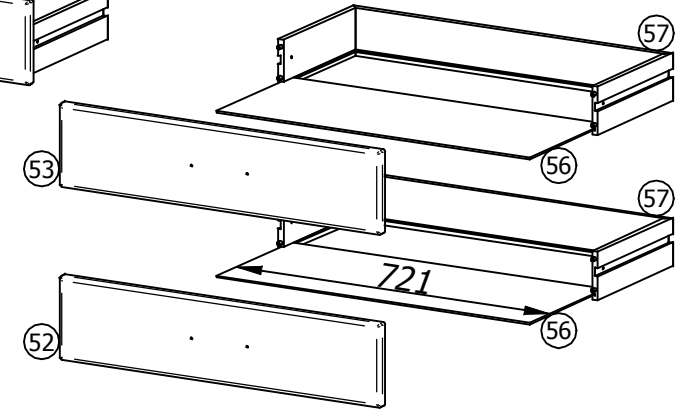
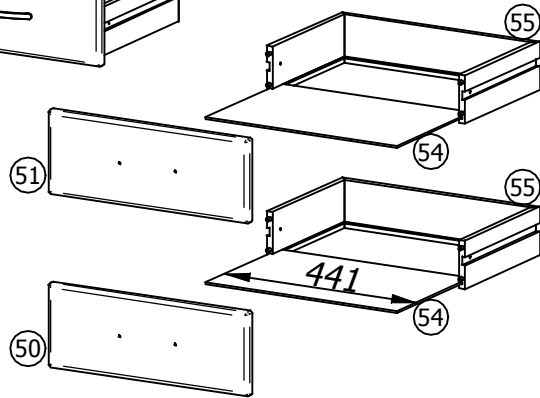
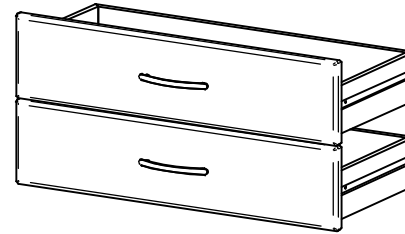
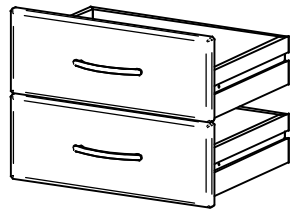

	OBERSCHUBKASTEN	AA O P	x2 N	x4 X	x4 AC x4 F x1 Y	S 5X-x4
	UNTERSCHUBKASTEN					$\varnothing 6.3 \times 11$ x8 P $\varnothing M4 \times 10$ x4 KE x4 M4x25 x4 F

1

2

3

4

