

	AA	 x2	NA	 x4	AC	 M4x25 x4	KE	 x4	P	 øM4x10 x4
					F	 x1	O	 ø6.3x11 x12	X	 x6
					Y				 ø3,5x20 x6	

# POINT S 84X

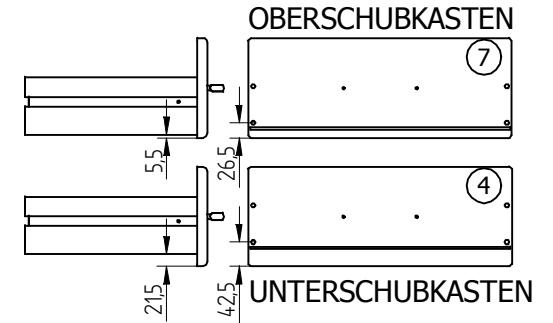
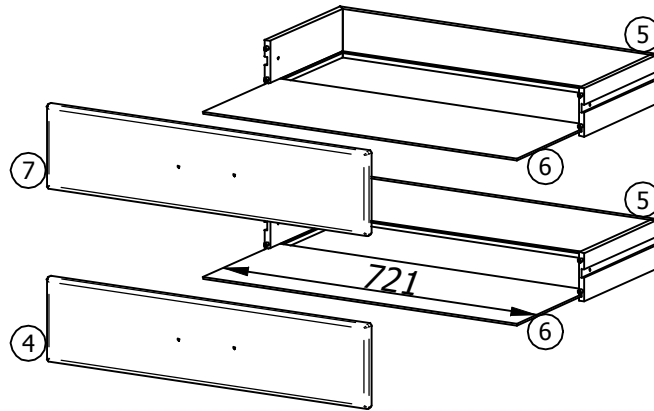
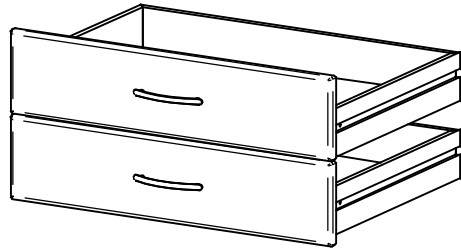

1

2

3

4

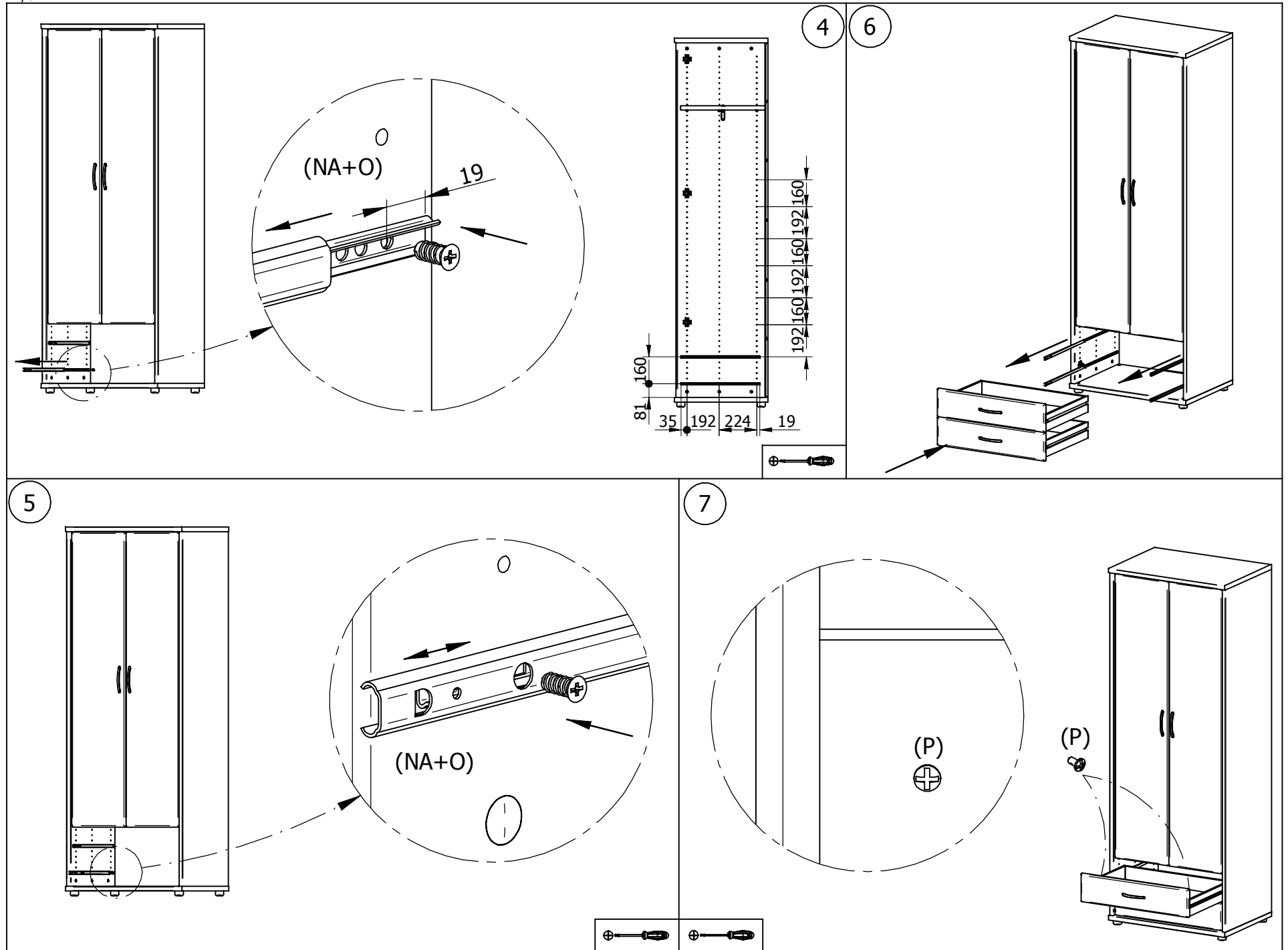

P1 KS 84 / POINT KS 84  
 P1 T 84 / POINT T 84  
 BASE KS 84 / T 84

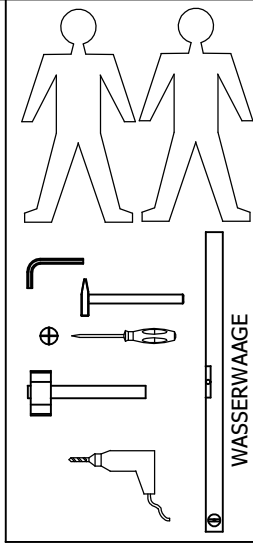
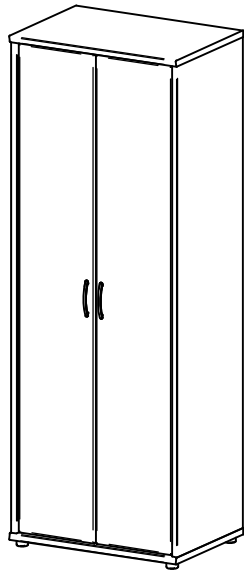

B		x8	EA		∅10x45 x20	G		∅5 x6	I		x4
C		x8	L		∅15 x12	M		∅8 x12	illustračný obrazok abbildung		
AA		x2	KD		∅15 x12	TA		M6x30 x2	Z		∅5/2x28 x4
AC		M4x25 x4	TC		x2	TC					
AD		x2	TC		x2	TC					
AB		x2	TC		x2	TC			JA		∅3.5x15 x16
AB		x2	TC		x2	TC			JD		∅4x25 x14

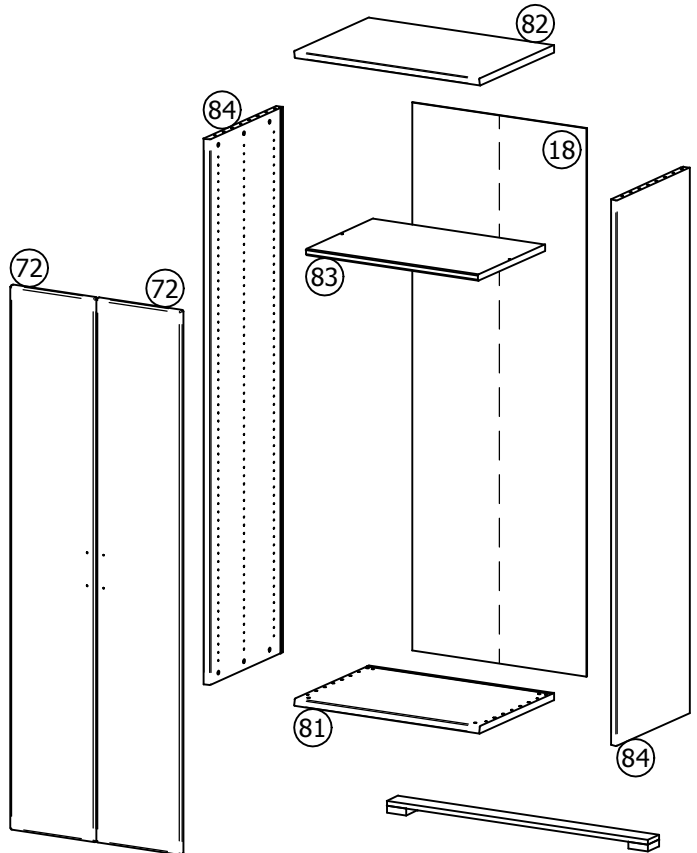

MONTAGESCHABLONE

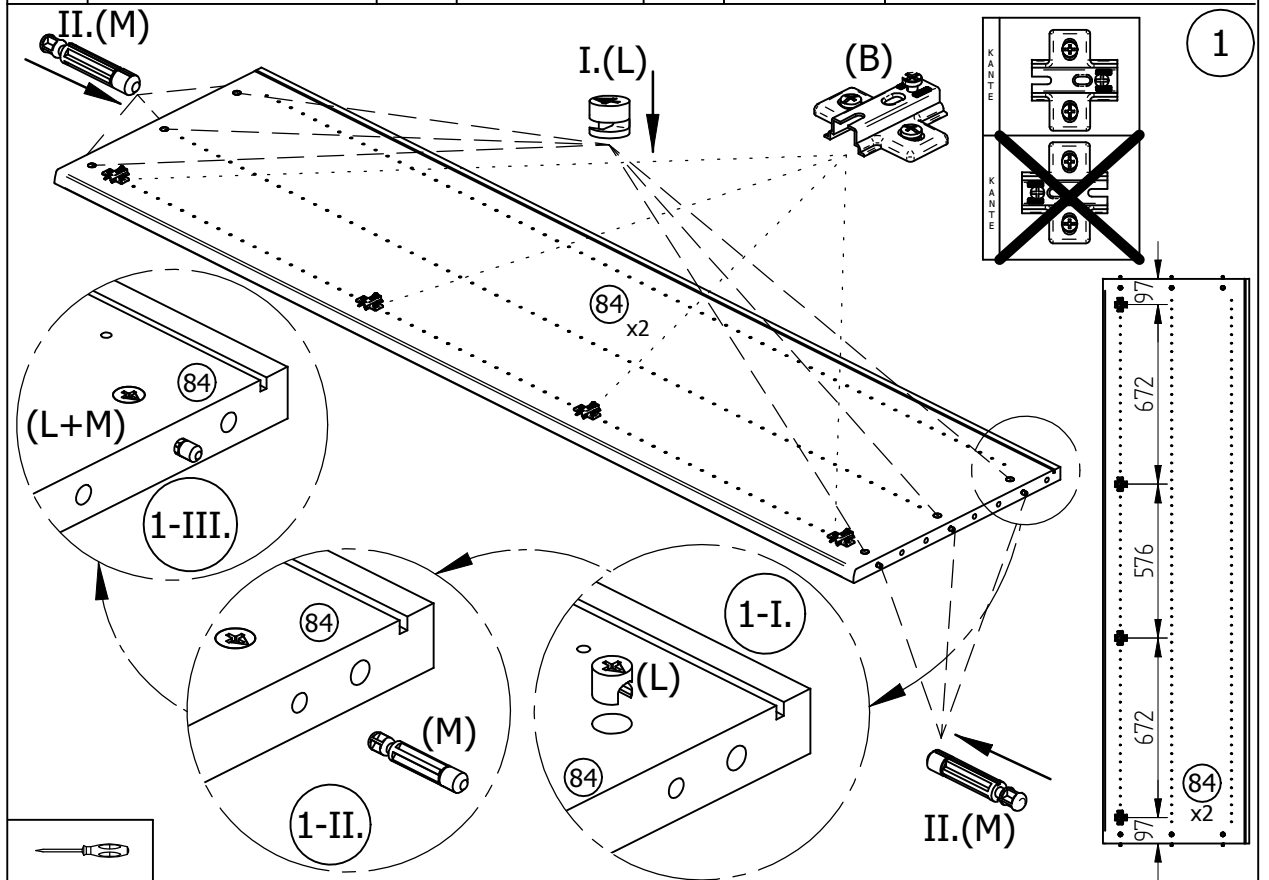

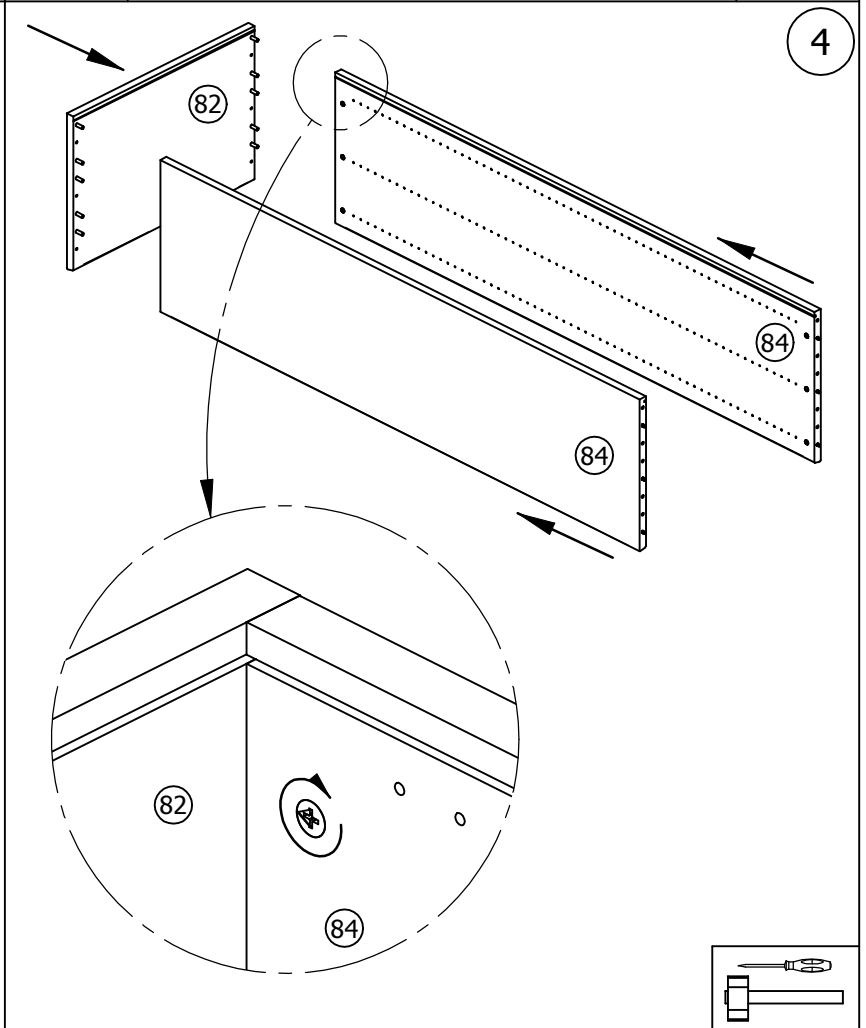
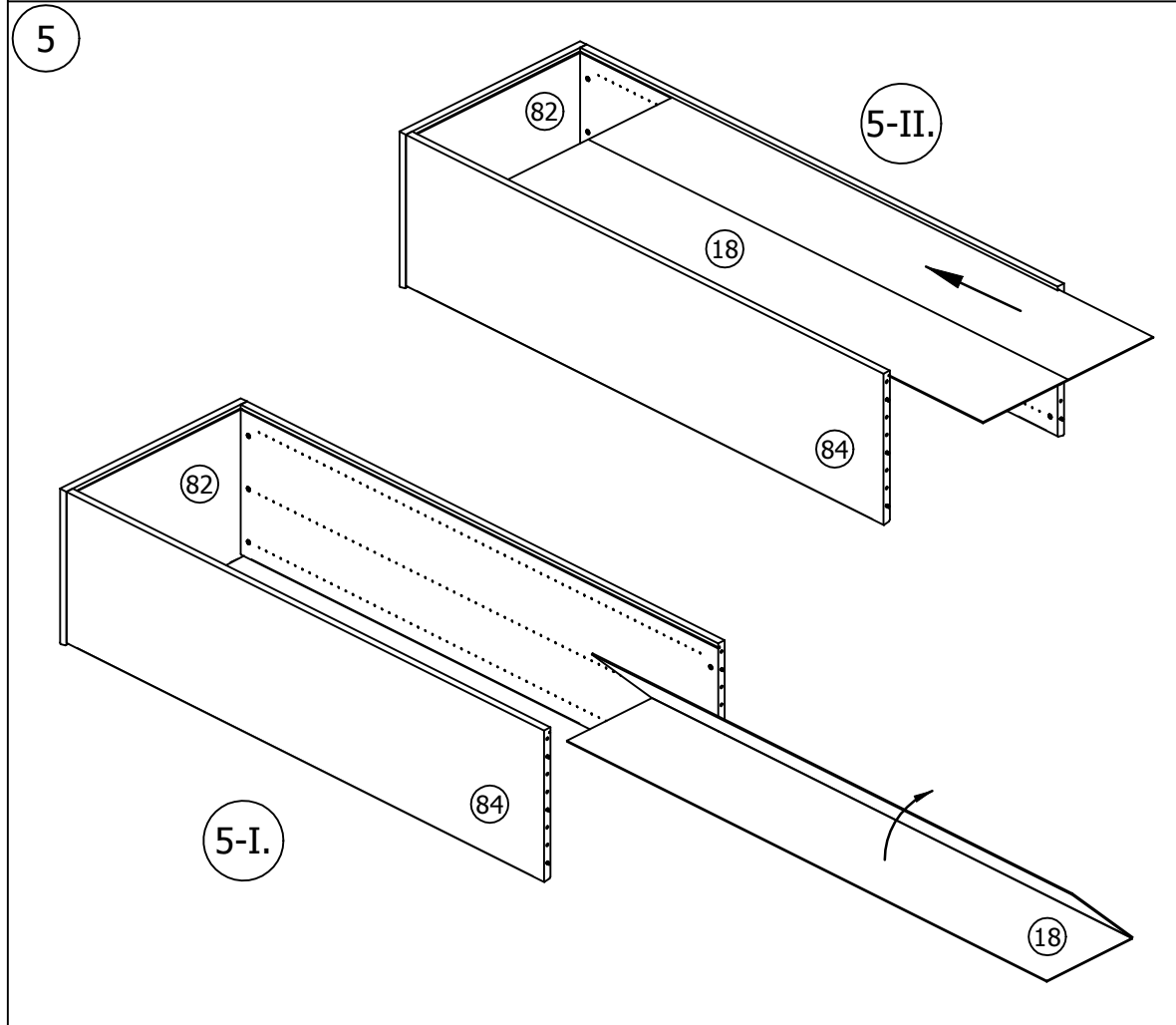
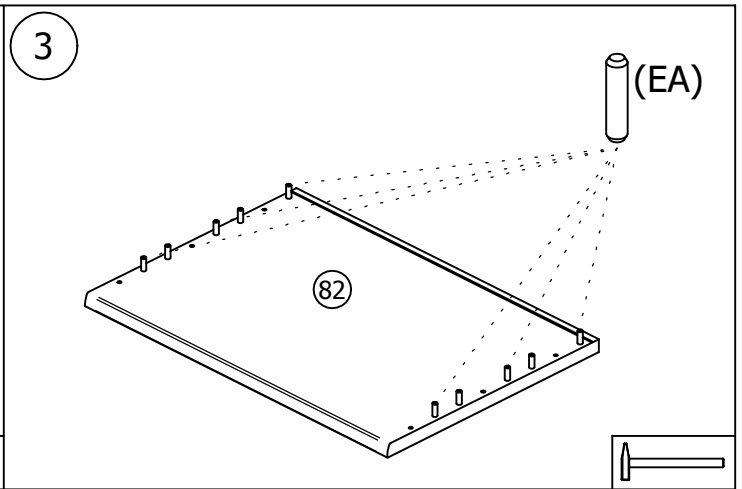
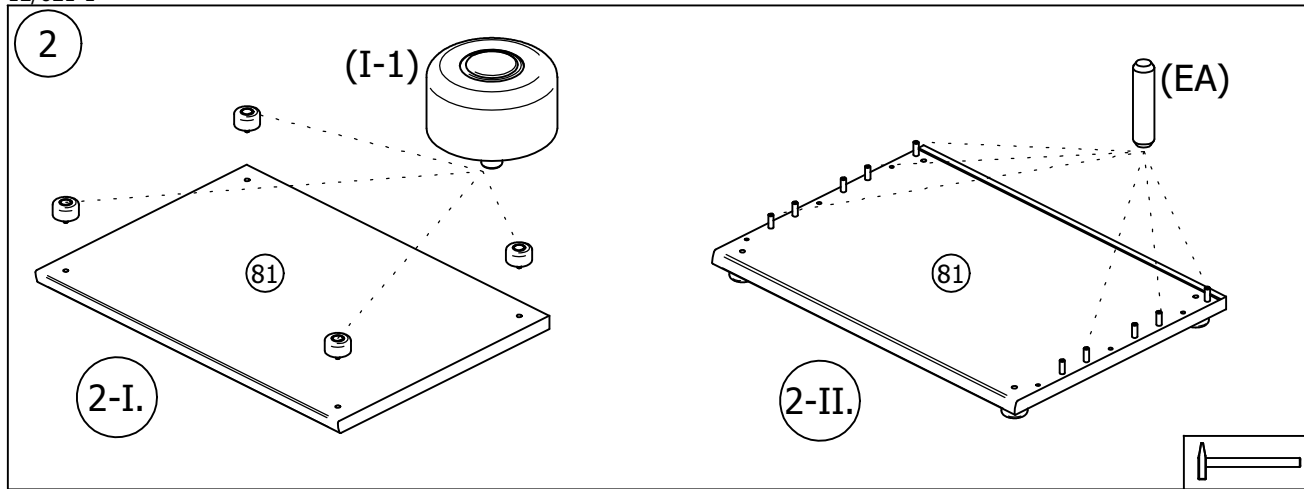

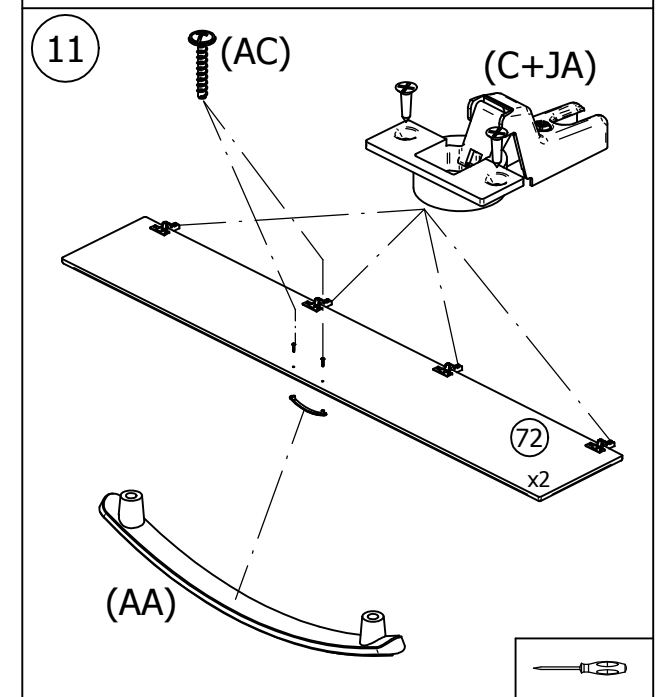
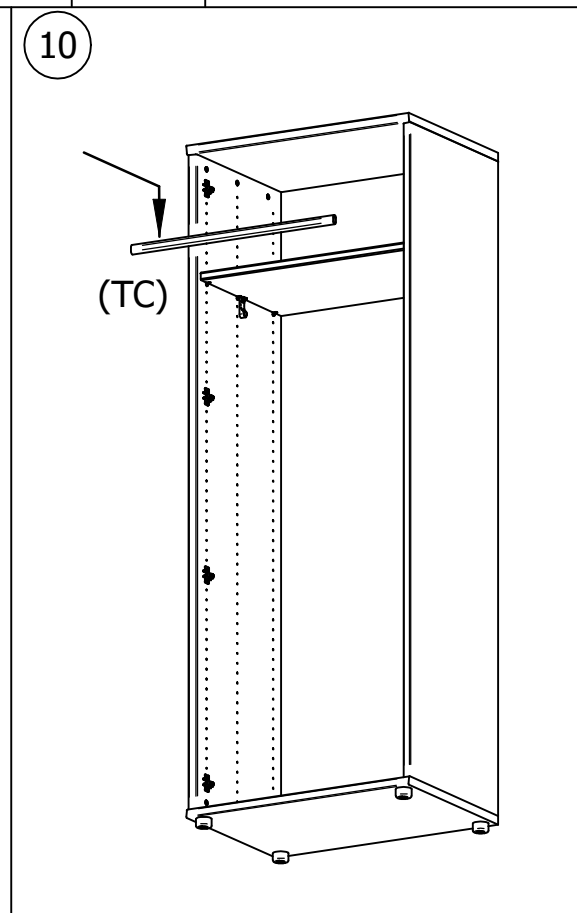
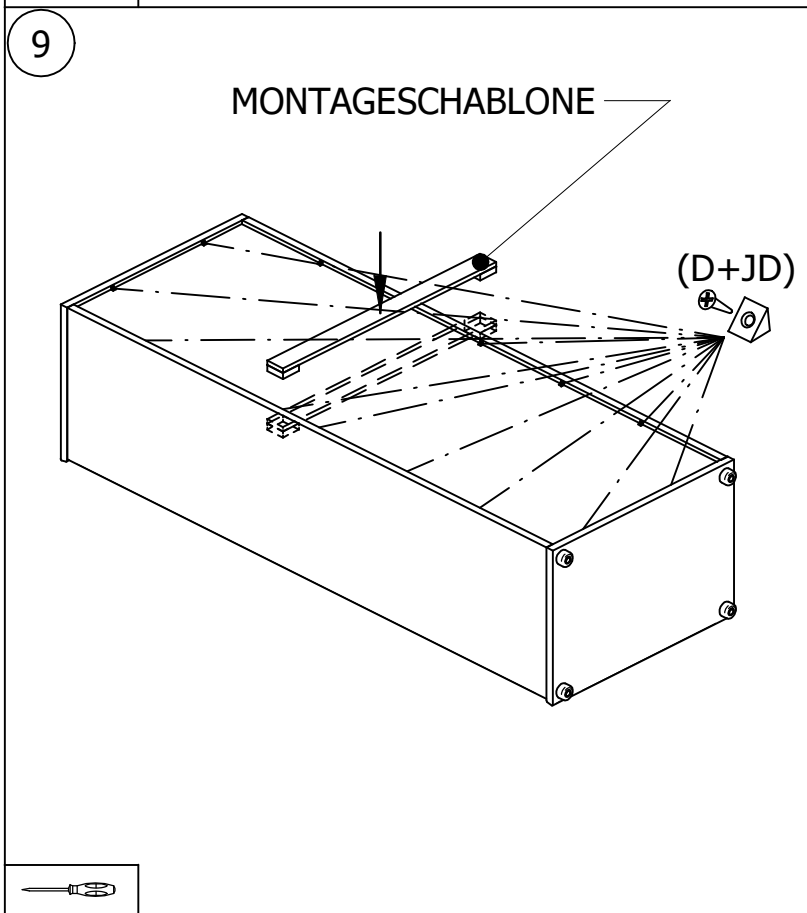
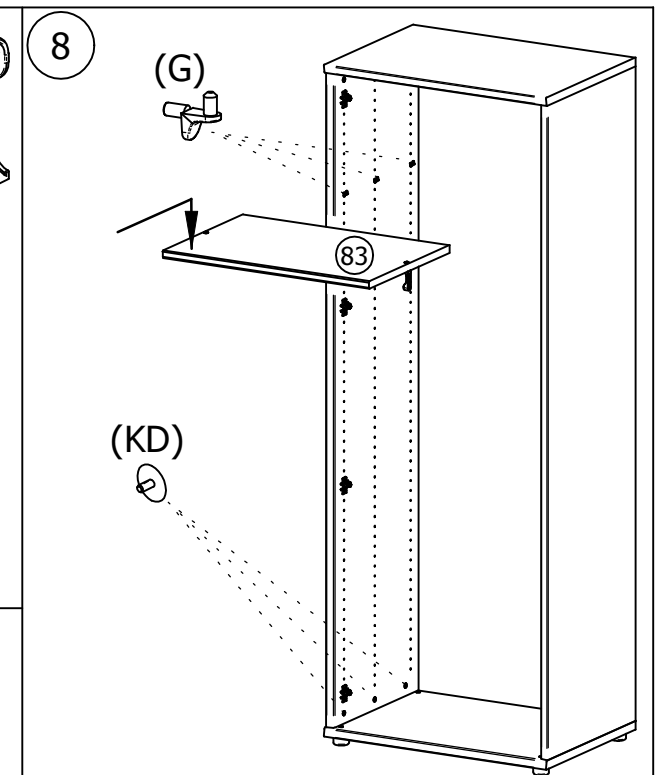
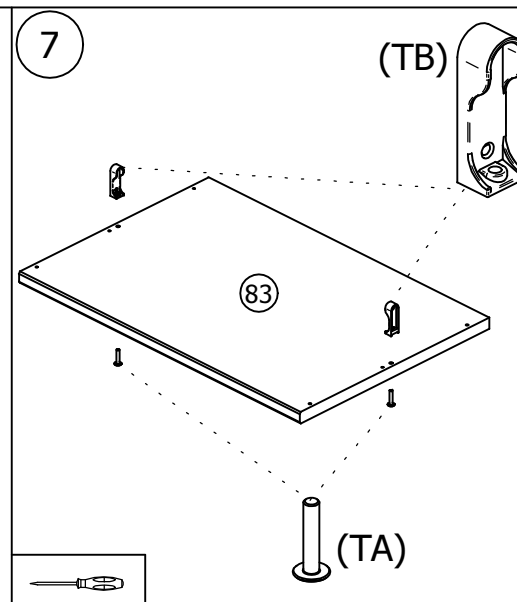
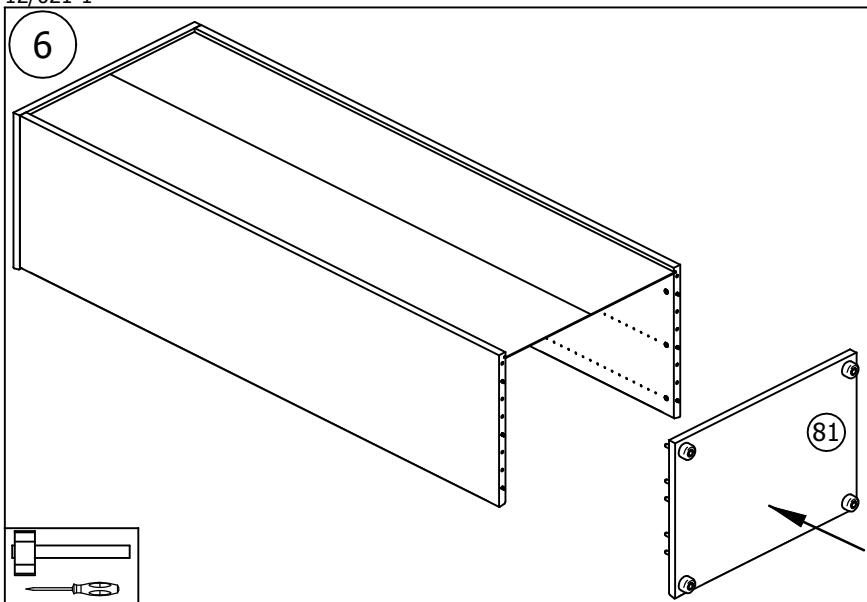

12

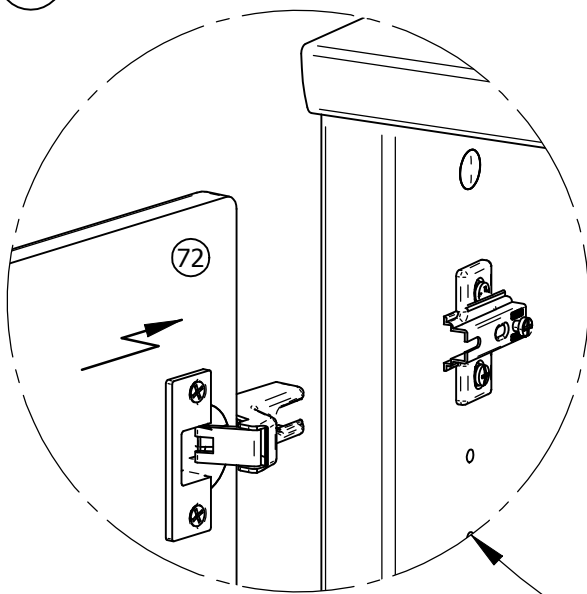

NASTAVENIE DVERÍ / EINSTELLUNG VON TÜREN	
	1. SKRUTKU B POVOLIŤ DIE SCHRAUBE B LÖSEN 2. DVERE VÝŠKOVO NASTAVIŤ TÜR IN DER HÖHE EINSTELLEN 3. SKRUTKU B DOTIAHNUŤ DIE SCHRAUBE B ZUZIEHEN
	1. SKRUTKU A POVOLIŤ DIE SCHRAUBE A LÖSEN 2. DVERE HLBKOVO NASTAVIŤ TÜR IN DER TIEFE EINSTELLEN 3. SKRUTKU A DOTIAHNUŤ DIE SCHRAUBE A ZUZIEHEN
	1. SKRUTKU A POVOLIŤ DIE SCHRAUBE A LÖSEN 2. DVERE STRANOVO SKRUTKOU C NASTAVIŤ TÜR SEITLIGS MIT SCHRAUBE C EINSTELLEN 3. SKRUTKU A DOTIAHNUŤ SCHRAUBE A ZUZIEHEN

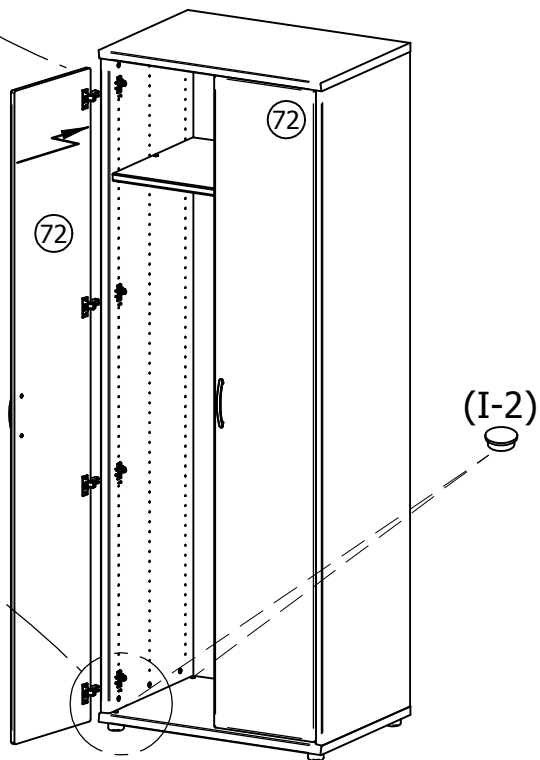
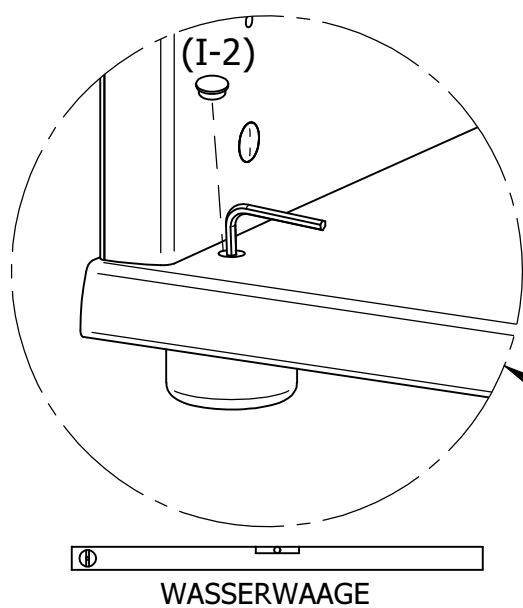

## RECTIFICATION



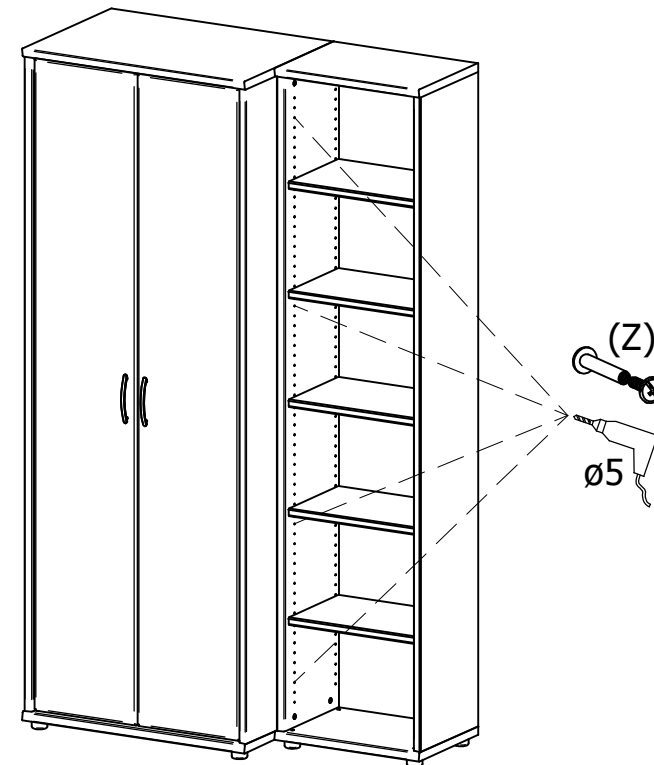



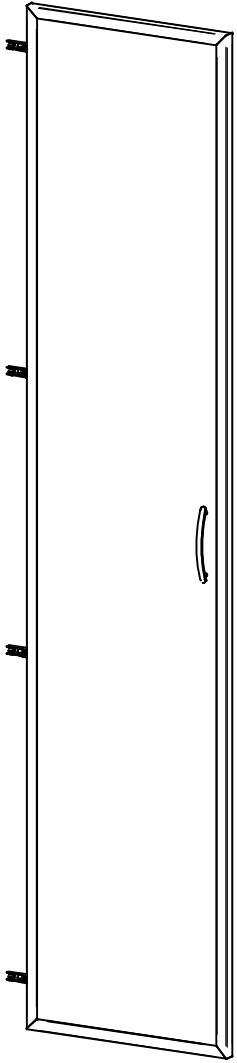
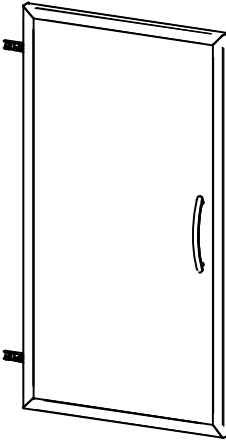
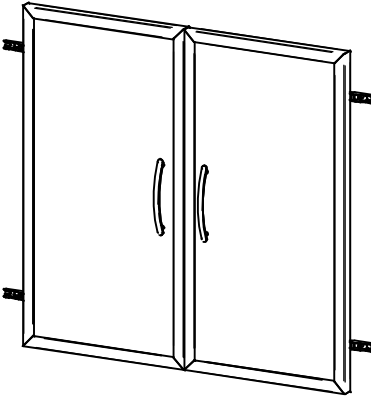
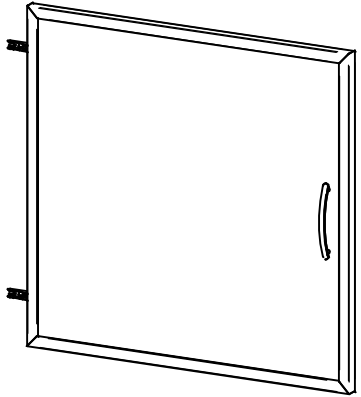

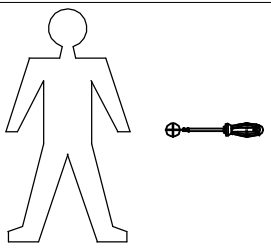
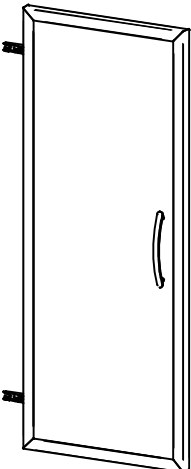
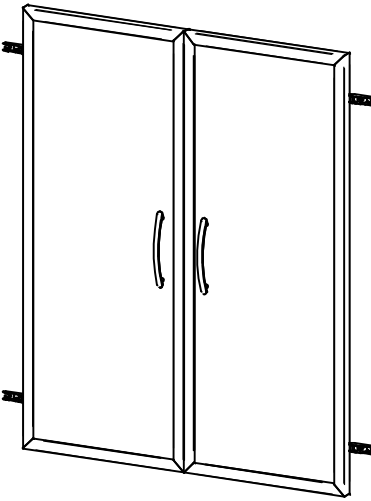
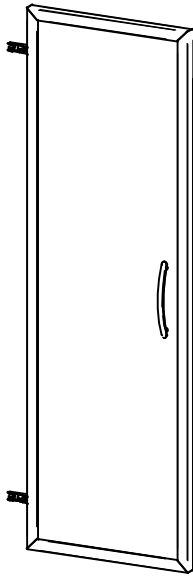
13

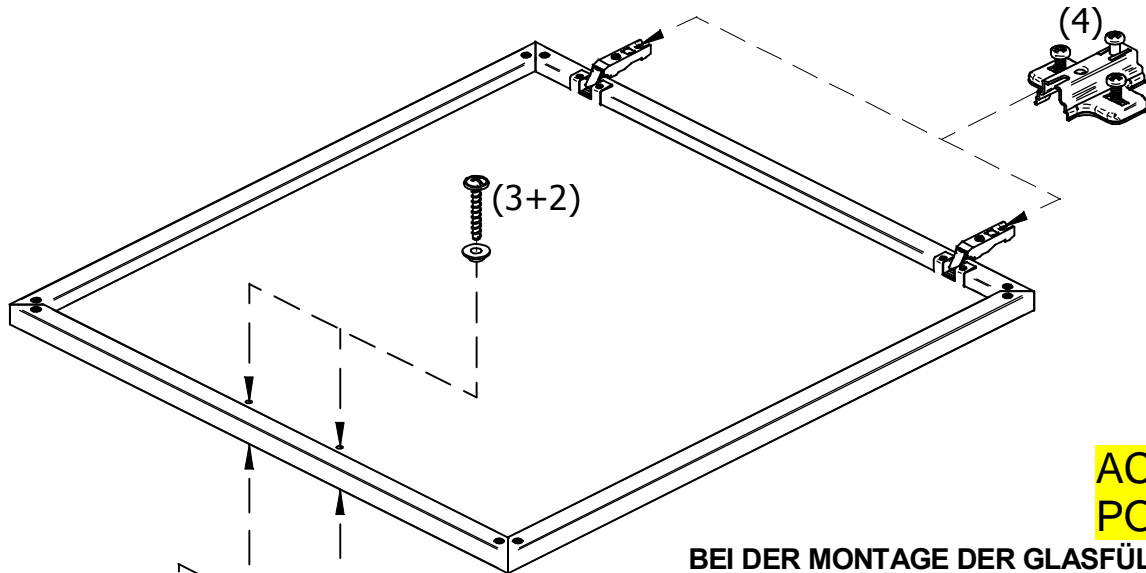
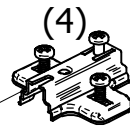

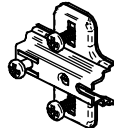
# MONTAGEANLEITUNG / MONTÁŽNY NÁVOD // SERVISKARTE / SERVISNÁ KARTA

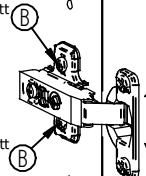
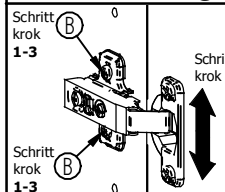
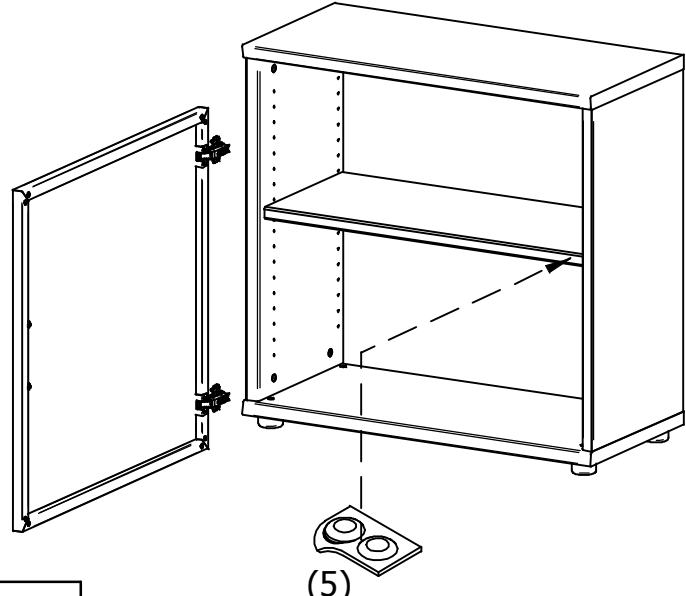
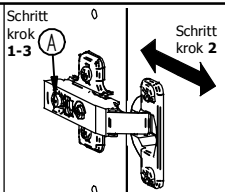
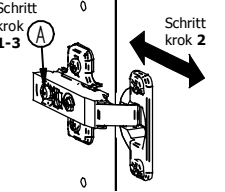
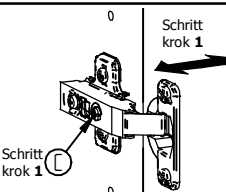
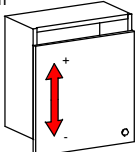
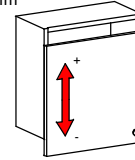
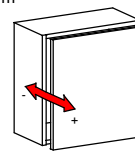
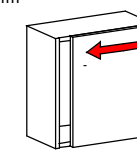
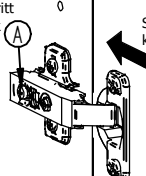
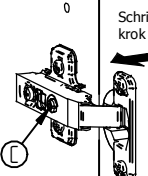
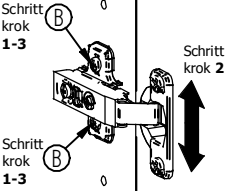
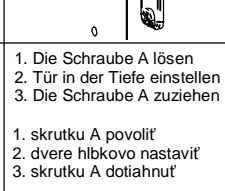
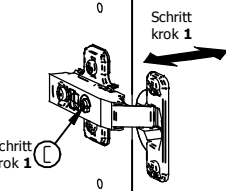
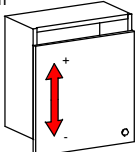
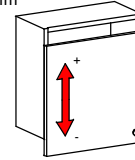
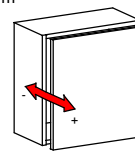
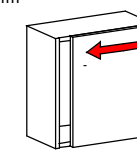
<p style="writing-mode: vertical-rl; transform: rotate(180deg);">POINT TYPE-T 54 AG/TYP-T 54 AG</p> 	<p style="writing-mode: vertical-rl; transform: rotate(180deg);">POINT TYPE-T 501 AG/TYP-T 501 AG</p> 	<p style="writing-mode: vertical-rl; transform: rotate(180deg);">POINT TYPE-T 80 AG/TYP-T 80 AG</p> 	<p style="writing-mode: vertical-rl; transform: rotate(180deg);">POINT TYPE-T 800 AG/TYP-T 800 AG</p> 	<p style="text-align: center; font-size: 2em;">1</p>	 <p>T 501 AG-x1 T 51 AG -x1 T 800 AG-x1 T 53 AG -x2 T 54 AG -x2 T 80 AG -x2 T 81 AG -x2</p>
	<p style="writing-mode: vertical-rl; transform: rotate(180deg);">POINT TYPE-T 51 AG/TYP-T 51 AG</p> 	<p style="writing-mode: vertical-rl; transform: rotate(180deg);">POINT TYPE-T 81 AG/TYP-T 81 AG</p> 	<p style="writing-mode: vertical-rl; transform: rotate(180deg);">POINT TYPE-T 53 AG/TYP-T 53 AG</p> 		<p style="text-align: center; font-size: 2em;">2</p>

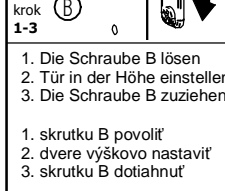
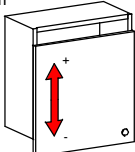
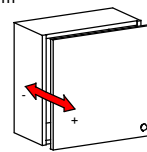
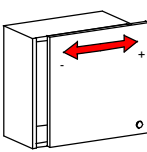
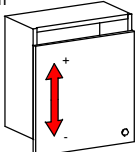
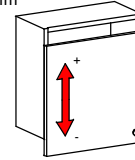
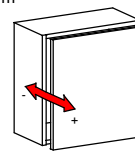
3	 T 501 AG-x2 T 51 AG -x2 T 800 AG x2 T 53 AG -x4 T 54 AG -x4 T 80 AG -x4 T 81 AG -x4		<div style="background-color: yellow; padding: 5px; display: inline-block;"><b>ACHTUNG!!! POZOR!!!</b></div>  <p><b>BEI DER MONTAGE DER GLASFÜLLUNG UND DES GRIFFES BITTE NUR MANUELLEN SCHRAUBENZIEHER EINSETZEN. PRI MONTÁŽI SKLENENEJ VÝPLNE A ÚCHYTKY POUŽÍVAJTE LEN RUČNÝ SKRUTKOAČ.</b></p>									
4	 T 501 AG-x2 T 51 AG -x2 T 800 AG x2 T 53 AG -x4 T 54 AG -x4 T 80 AG -x4 T 81 AG -x4											
5	 T 501 AG-x2 T 51 AG -x2 T 800 AG x2 T 53 AG -x4 T 54 AG -x4 T 80 AG -x4 T 81 AG -x4		<h3 style="text-align: center;">Einstellung von Türen / Nastavenie dverí</h3> <table border="1" style="width: 100%; border-collapse: collapse;"> <tbody> <tr> <td style="width: 33%; vertical-align: top;"> <p>Schritt krok 1-3</p>  <p>Schritt krok 1-3</p>  </td> <td style="width: 33%; vertical-align: top;"> <p>Schritt krok 1-3</p>  <p>Schritt krok 2</p>  </td> <td style="width: 33%; vertical-align: top;"> <p>Schritt krok 1</p>  <p>Schritt krok 1</p>  </td> </tr> <tr> <td style="vertical-align: top;"> <p>1. Die Schraube B lösen 2. Tür in der Höhe einstellen 3. Die Schraube B zuziehen</p> <p>1. skrutku B povoliť 2. dvere výškovo nastaviť 3. skrutku B dotiahnuť</p> </td> <td style="vertical-align: top;"> <p>1. Die Schraube A lösen 2. Tür in der Tiefe einstellen 3. Die Schraube A zuziehen</p> <p>1. skrutku A povoliť 2. dvere hĺbkovo nastaviť 3. skrutku A dotiahnuť</p> </td> <td style="vertical-align: top;"> <p>1. Tür seitlgs mit Schraube C einstellen</p> <p>1. dvore stranovo skrutkou C nastaviť</p> </td> </tr> <tr> <td style="vertical-align: top;"> <p>+ 2 mm - 2 mm</p>  </td> <td style="vertical-align: top;"> <p>+ 3 mm - 1 mm</p>  </td> <td style="vertical-align: top;"> <p>+ 5 mm - 1,5 mm</p>  </td> </tr> </tbody> </table>	<p>Schritt krok 1-3</p>  <p>Schritt krok 1-3</p> 	<p>Schritt krok 1-3</p>  <p>Schritt krok 2</p> 	<p>Schritt krok 1</p>  <p>Schritt krok 1</p> 	<p>1. Die Schraube B lösen 2. Tür in der Höhe einstellen 3. Die Schraube B zuziehen</p> <p>1. skrutku B povoliť 2. dvere výškovo nastaviť 3. skrutku B dotiahnuť</p>	<p>1. Die Schraube A lösen 2. Tür in der Tiefe einstellen 3. Die Schraube A zuziehen</p> <p>1. skrutku A povoliť 2. dvere hĺbkovo nastaviť 3. skrutku A dotiahnuť</p>	<p>1. Tür seitlgs mit Schraube C einstellen</p> <p>1. dvore stranovo skrutkou C nastaviť</p>	<p>+ 2 mm - 2 mm</p> 	<p>+ 3 mm - 1 mm</p> 	<p>+ 5 mm - 1,5 mm</p> 
<p>Schritt krok 1-3</p>  <p>Schritt krok 1-3</p> 	<p>Schritt krok 1-3</p>  <p>Schritt krok 2</p> 	<p>Schritt krok 1</p>  <p>Schritt krok 1</p> 										
<p>1. Die Schraube B lösen 2. Tür in der Höhe einstellen 3. Die Schraube B zuziehen</p> <p>1. skrutku B povoliť 2. dvere výškovo nastaviť 3. skrutku B dotiahnuť</p>	<p>1. Die Schraube A lösen 2. Tür in der Tiefe einstellen 3. Die Schraube A zuziehen</p> <p>1. skrutku A povoliť 2. dvere hĺbkovo nastaviť 3. skrutku A dotiahnuť</p>	<p>1. Tür seitlgs mit Schraube C einstellen</p> <p>1. dvore stranovo skrutkou C nastaviť</p>										
<p>+ 2 mm - 2 mm</p> 	<p>+ 3 mm - 1 mm</p> 	<p>+ 5 mm - 1,5 mm</p> 